



# INSTRUCTIONS

J04977

2011-05-26



## BOOM! AUDIO MUSIC AND INTERCOM KIT

### GENERAL

#### Kit Number

77108-09A

#### Models

For model fitment information, see the P&A retail catalog or the Parts and Accessories section of [www.harley-davidson.com](http://www.harley-davidson.com) (English only).

#### Additional Parts Required

An intercom system software update (H-D Part No. 76441-06DT) performed by a Harley-Davidson dealer.

Non-Ultra Overlay Harness (H-D Part No. 70169-06)

#### NOTE

For a more integrated appearance of the rider headset connector, the console may be replaced using an Ultra Classic Electra Glide console and/or console pod. See FLHTCU parts manual for applicable parts, and service manual for installation instructions.

#### ⚠ WARNING

Rider and passenger safety depend upon the correct installation of this kit. Use the appropriate service manual procedures. If the procedure is not within your capabilities or you do not have the correct tools, have a Harley-Davidson dealer perform the installation. Improper installation of this kit could result in death or serious injury. (00333b)

#### NOTE

This instruction sheet refers to service manual information. A service manual for this year/model motorcycle is required for this installation and is available from a Harley-Davidson dealer.

#### Kit Contents

See Figure 7 and Table 2.

### REMOVAL

1. Refer to the service manual and remove the following:
  - a. Main fuse.
  - b. Outer fairing.
  - c. Seat.
  - d. Fuel tank and console.
  - e. Inner fairing cap.
  - f. Wire trough cover.
  - g. Left hand control.
  - h. Left side saddlebag.

### INSTALLATION

#### Install Switch Housing on Passenger Headset Harness

1. See Figure 1. Install push-to-talk switch housing (2) to passenger headset plug housing (3), included as part of passenger headset wire harness (see Figure 7, Item 10).
2. Position the switch housing so the knob is located close to the flip cap on the passenger headset connector.
3. Install self-tapping screws (1) to the switch housing but do not fully tighten at this time. Location adjustment may be required based on the motorcycle model, seats and accessories installed on the vehicle.

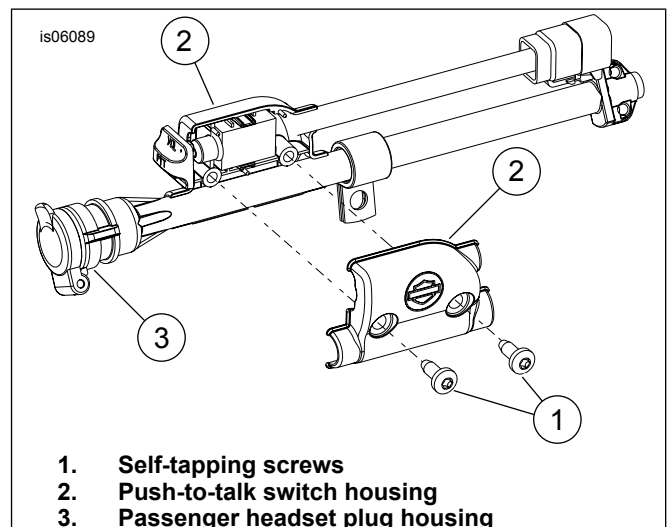

Figure 1. Install Push-to-Talk Switch Housing

## Install Push-to-Talk/Audio Left-Hand Control and Speaker Selector Switch

1. Refer to the service manual to install the Push-to-Talk/Audio left-hand control and speaker selector switch and adapter wire (as required).

### NOTE

Reuse original clutch switch if the vehicle is equipped with a hydraulic clutch master cylinder.

## Route Overlay Harness

1. Install the non-Ultra Overlay Harness (purchased separately) using the instructions included with the XM Satellite Radio or Bike-to-Bike Communications Kit.
2. See Figure 7. Remove the spring and conduit from the passenger headset wire harness (10).
3. Refer to the service manual for instructions to secure the overlay harness inside the fairing.
4. Route the passenger headset wire harness through the inner fairing and through the left frame P-clamp. Replace the P-clamp fastener.
5. Connect the 8-way connector of the passenger headset wire harness (10) to the mating connector on the Non-Ultra Overlay Harness (installed in Step 1) marked "PASSENGER HEADSET".
6. Connect the 6-way connector of the PTT/VOL jumper harness (22) to the mating connector of the Non-Ultra overlay harness marked "RIGHT REAR SPEAKER CONTROL". Connect the other end of the jumper to the connector on the switch subassembly (1).
7. See Figure 1. Route the 6-way connector [41], push-to-talk switch housing (2) and passenger headset plug housing (3) connector [76] down the left side to the rear fender support cover.
8. Double back the harness so the headset plug housing (3) flip-lid faces the front of the vehicle.

## Secure Headset Connector and Switch Housing

1. **2006-2008 FLHX, FLTR, FLHT/C models:** For motorcycles WITHOUT docking hardware, See Figure 7. Use the fender support cover fastener to install the smaller P-clamp (15) from the kit. For vehicles WITH docking hardware, use the front docking point fastener. Install the smaller P-clamp (15) between the outer face of the docking point and the washer. **2009-later FLHX, FLTR, FLHT/C models:** For motorcycles WITHOUT docking hardware, see Figure 2. Use the threaded hole in the frame using screw (4), washer (3), spacer (2) and the smaller P-clamp (5) from the kit. For motorcycles WITH docking hardware, use the docking point shown in Figure 3. Install the smaller P-clamp from the kit to the outer end of the docking point using the docking point washer and screw. **2009-later Trike models without Tour-Pak (FLHXXX):** See Figure 4. The headset/switch assembly (1) will be secured to the frame at the location shown using the 1/2-13 screw (3) and the larger P-clamp (2) from the kit.
2. **For ALL models:** Once the position of the PTT/VOL switch has been established, securely tighten the self-tapping screws installed to the switch housing earlier.

### NOTE

2011 and later models will require the connector on the switch subassembly ( Figure 7, item 1) to be replaced with the supplied housing and terminals (items 23 and 24) included in this kit. See service manual for installation instructions.

Table 1. PTT Switch Pod

Wire Color	Cavity	Wire Color	Cavity
PK/W	1	O/BK	4
GY/W	2	PLUG	5
V/BK	3	PLUG	6

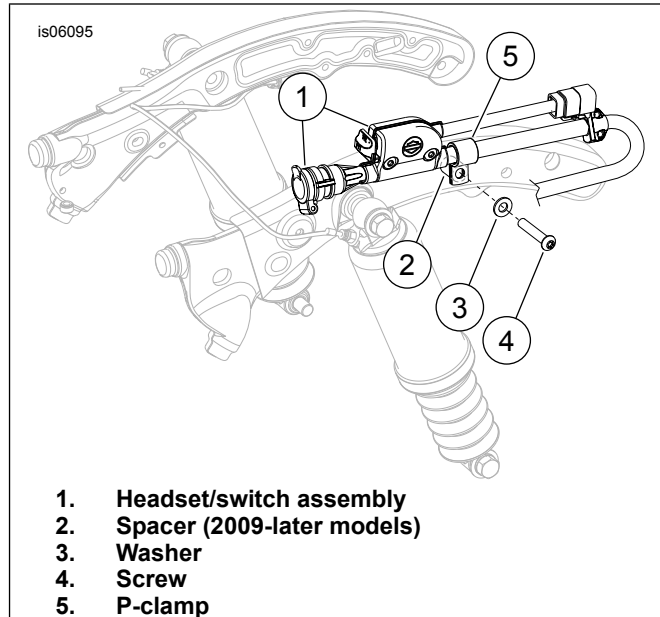

Figure 2. Installation Without Docking Points

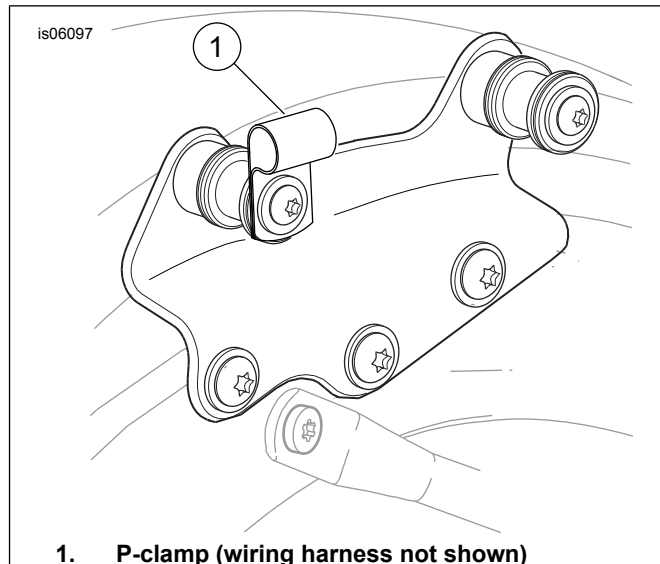

Figure 3. Installation With Docking Points

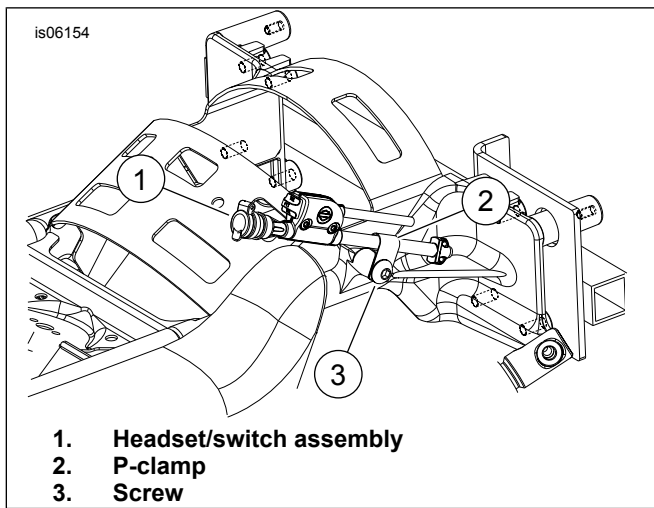

Figure 4. Installation on Trikes Without Tour-Pak

## Install Rider Headset Connector

1. See Figure 5. Connect the rider headset harness to the 12-way connector of the Non-Ultra Overlay Harness.
2. Route the harness down the left side of the frame tube about 15.2 cm (6.0 in) past the lower console mount fastener.
3. Install the fuel tank per service manual instructions.

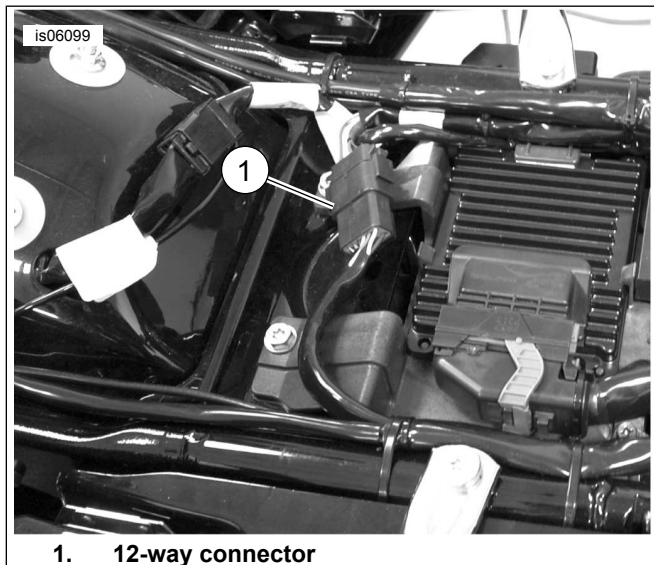

Figure 5. 12-Way Connector of Overlay Harness

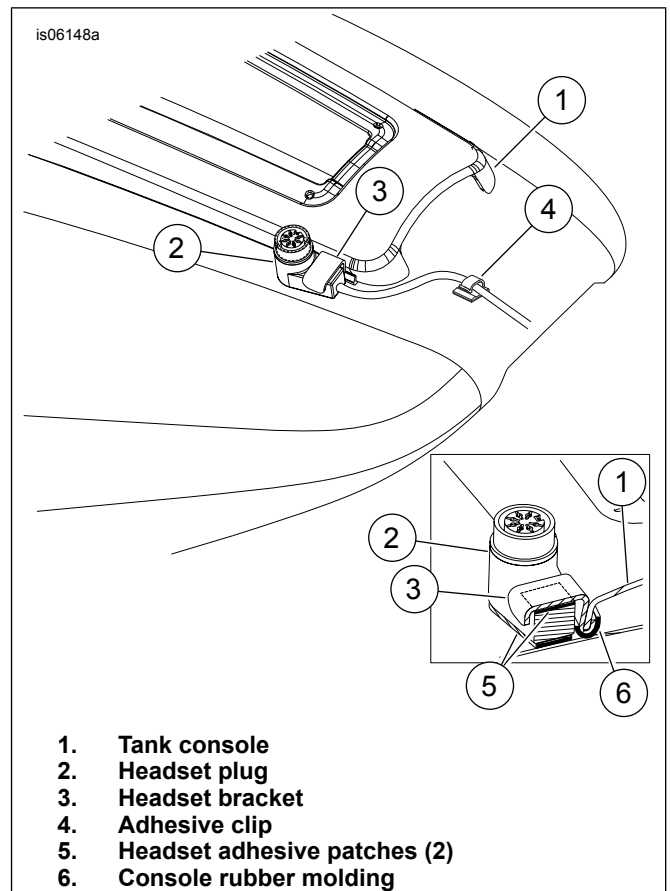

Figure 6. Mounting Rider Headset Plug

4. See Figure 6. Clean the clip mounting area with a mixture of 50-70% isopropyl alcohol and 30-50% distilled water. Allow to dry thoroughly. The adhesive back clip will be secured to the lower portion of the fuel tank, so it will be covered by the seat.
  - a. Install the adhesive back clip (4) on the wire harness. Do not remove the adhesive backer at this time.
  - b. Install the narrow end of the headset bracket (3) between the console molding strip and the console at the lower left corner of the console as shown in Figure 6.
  - c. Trim the adhesive patch (5) to the shape of the back of the headset plug (2), remove one side of backer and apply to the back of the connector plug to protect the tank from scuffing. Trim the adhesive patch to a 12 x 6 mm ( x in) rectangle. Remove one side of the backer and apply to the underside of the bracket as shown.
  - d. Position the headset connector facing up and use the wider end of the bracket to secure the flat portion of the headset connector as shown.
  - e. Remove the backer from the bottom of the adhesive patches to secure the bracket to the connector and connector to the fuel tank.
  - f. Install the adhesive back clip (4) as shown. Remove the adhesive backer from the clip and install the clip onto the fuel tank where it will be covered by the seat.

**NOTE**

Allow **AT LEAST 24 hours** after applying the clip before exposing the area to vigorous washing, strong water spray or extreme weather.

5. See Figure 7. Install the weather cap (7) assembly on the rider headset connector by installing the locking ring inside the flip cap.

6. Secure all wiring with cable straps as needed. Check the motorcycle to verify that the wire harness does not interfere with the steering, suspension travel or any other moving parts of the motorcycle.

7. Refer to the service manual to install all the components removed in **REMOVAL**, Step 1.

**SERVICE PARTS**

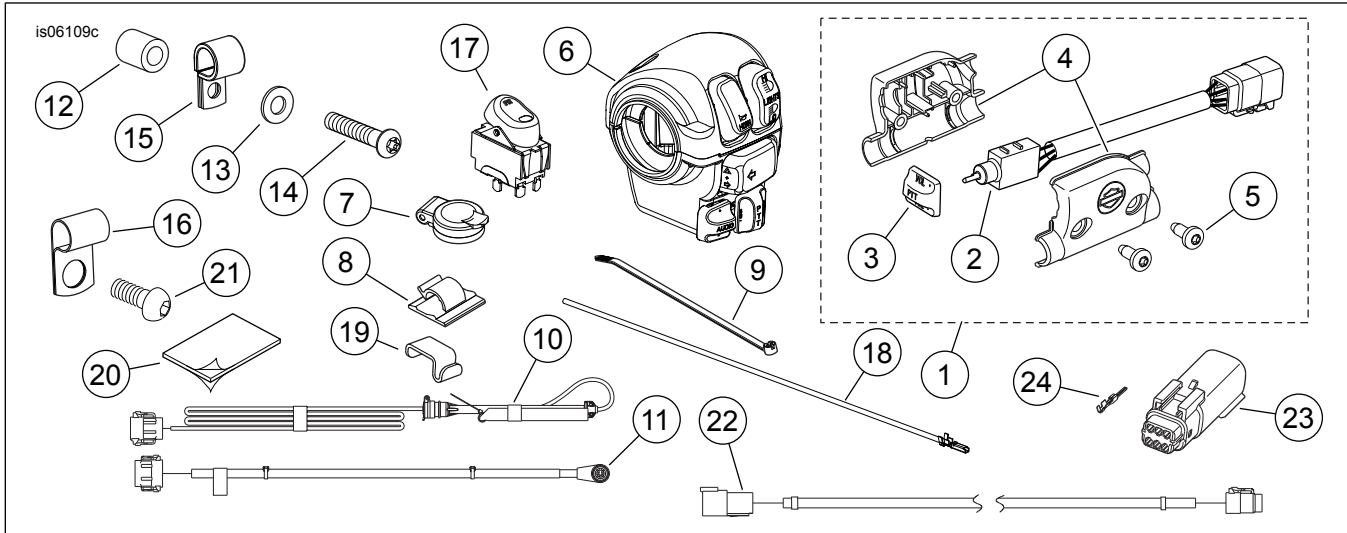

**Figure 7. Service Parts, Music and Intercom Kit**

**Table 2. Service Parts**

Item	Description (Quantity)	Part Number
1	Switch and housing subassembly (includes items 2-5)	77133-09
2	• Switch assembly (includes item 3)	Not sold separately
3	• Knob, PTT VOL-/VOL+	71814-98
4	• Switch housing	Not sold separately
5	• Screw, pan head TORX®, #10 x 13 mm (1/2 in) (2)	3152
6	Left hand control, PTT/Audio	Not sold separately
7	Weather cap assembly	76266-98
8	Clip, nylon, self adhesive	Not sold separately
9	Cable strap (10)	10006
10	Passenger headset wire harness	Not sold separately
11	Rider headset harness, 7 pin	77114-09
12	Spacer	Not sold separately
13	Flat washer (chrome)	94066-90T
14	Screw, button head TORX, 5/16-18	Not sold separately
15	Cushioned P-clamp (smaller)	9990W
16	Cushioned P-clamp (larger)	10036
17	Speaker selector switch	77092-98
18	Wire adapter	Not sold separately
19	Rider headset bracket	Not sold separately
20	Adhesive patch, 38 x 25 mm ( x in)	Not sold separately
21	Screw, 1/2-13 x 19 mm (0.75 in) long	868A
22	PTT/VOL jumper harness	77120-09
23	Pin housing, six-way (black)	72188-07BK
24	Pin terminal, #16-20 AWG	72169-07

**FEATURES OF ADVANCED AUDIO RADIO**

**Understanding Speaker/Volume Features**

A three-position speaker switch is:

- Standard on FLHTCU, FLHTCUTG, and FLHTK models.
- Included in kits 77107-09 and 77108-09A.

**Basic points to remember:**

- The speaker switch controls the location through which music and bike-to-bike communications are heard (speakers or headsets).
- Rider-to-passenger communications ("Intercom") are ALWAYS heard through the headsets, regardless of switch position.

In the **down** position (nearest rider), audio and bike-to-bike communication will be heard through the vehicles speakers. Intercom will come through the rider and passenger headsets.

In the **middle** position, audio will be heard through the vehicle speakers. Bike-to-bike communication and intercom will come through the rider and passenger headsets.

In the **up** position (furthest from the rider), audio, bike-to-bike communication and intercom will come through the rider and passenger headsets.

## Volume Settings

### Basic points to remember:

- There are separate volume settings for speaker and front and rear headsets.
- There are separate volume settings for Music, Intercom, and bike-to-bike (CB).
- Getting these volume settings out of proper adjustment is likely the second-most confusing/frustrating aspect a customer could encounter (after Voice Activation, covered in the section that follows).

Volume settings for audio, communication, and intercom are all independent and all adjusted by using the AUDIO +/- switch on the rider left hand control or passenger PTT/VOL+/VOL-switch.

**Audio (music) SPEAKER** volume can be adjusted by the RIDER ONLY while listening to music via speakers by pressing up or down on the AUDIO button on the left hand control.

- Note that a "Speaker" icon displays on screen.

**Audio (music) HEADSET** volume can be adjusted by rider OR passenger independently while listening to music by pressing up or down on the AUDIO button on the left hand control or passenger PTT switch.

- Note "F" for front/rider and "R" for rear/passenger settings display on screen in headset mode.

**Intercom** volume adjustment can be accessed by pressing the INT button on the radio face. It can only be adjusted in INT mode.

- Volume can be adjusted by rider OR passenger independently.
- Note "F" for front/rider and "R" for rear/passenger volume settings displayed on screen .
- Press the INT button again to return to normal music operation.

**Bike-to-bike communication** volume adjustment can be accessed by pressing the COM button on the radio face. It can only be adjusted in COM mode.

- Volume can be adjusted by rider OR passenger independently.
- Note "F" for front/rider and "R" for rear/passenger volume settings displayed on screen.

- Press the COM button again to return to normal music operation.
- The rider or passenger can press the PTT button to communicate with other motorcycles or vehicles equipped with a CB system.

## Understanding Intercom Voice Activation

### NOTE

*This feature works with few problems when set up properly, but can be the biggest source of confusion and frustration for an inexperienced user.*

VOX, Voice Operated eXchange, (a.k.a. "Voice Activation") is used to open and close the microphone when rider and passenger are using intercom to talk to each other while riding. When the microphone is "open", the music being played is muted slightly to become "background music" during conversation. Once the microphone closes, music volume returns to its previous setting.

This VOX sensitivity setting can be adjusted by pressing the INT button on the radio face and utilizing the MODE SEL UP/DN switch on the right hand control.

- Turning the sensitivity **down** will require the rider and passenger to speak louder to start a conversation.
- Turning the sensitivity **up** will open the microphone more easily, with lesser voice strength needed.
- As road conditions change, highway vs. city streets, or as the wind changes, adjustments to VOX will likely be required, since the background noise is added to the spoken voice level to "break" the VOX setting and open the microphone.

### NOTE

*Music is muted (whether in speakers or headsets) whenever the VOX is opened for intercom use. Unexplained, intermittent music volume can often be due to VOX setting being set too sensitively for the current conditions, causing the microphone to open and "mute" the music intermittently.*