



INSTRUCTIONS

J05266

2011-07-28



BOOM! AUDIO AMPLIFIER KIT

GENERAL

Kit Number

76000070, 76000074

Models

For model fitment information, see the P&A retail catalog or the Parts and Accessories section of www.harley-davidson.com (English only).

Additional Parts Required

Models not equipped with a Non-Ultra Overlay Harness (Part No. 70169-06) will require the separate purchase of a Radio Wire Harness (Part No. 69200106).

Tools and Supplies Required

Loctite[®] 243 Threadlocker and Sealant - Blue (Part No. 99642-97) is required for the proper installation of this kit.

⚠ WARNING

Rider and passenger safety depend upon the correct installation of this kit. Use the appropriate service manual procedures. If the procedure is not within your capabilities or you do not have the correct tools, have a Harley-Davidson dealer perform the installation. Improper installation of this kit could result in death or serious injury. (00333b)

NOTE

This instruction sheet refers to service manual information. A service manual for this year/model motorcycle is required for this installation and is available from a Harley-Davidson dealer.

Electrical Overload

NOTICE

It is possible to overload the vehicle's charging system by adding too many electrical accessories. If the combined electrical accessories operating at any one time consume more electrical current than the vehicle's charging system can produce, the electrical consumption can discharge the battery and cause damage to the vehicle's electrical system. (00211d)

⚠ WARNING

When installing any electrical accessory, be certain not to exceed the maximum amperage rating of the fuse or circuit breaker protecting the affected circuit being modified. Exceeding the maximum amperage can lead to electrical failures, which could result in death or serious injury. (00310a)

This amplifier requires up to **11 amps** additional current from the electrical system.

Kit Contents

See Figure 5 and Table 1.

INSTALLATION

Preparation

NOTE

For vehicles equipped with security siren:

- Verify that the Hands-Free Fob is present.
- Turn the ignition key switch to IGNITION.

1. Refer to the service manual and follow the instructions to remove the main fuse.
2. Follow the service manual instructions to remove the seat.

⚠ WARNING

Disconnect negative (-) battery cable first. If positive (+) cable should contact ground with negative (-) cable connected, the resulting sparks can cause a battery explosion, which could result in death or serious injury. (00049a)

3. **For 2006 and 2007 models:** See the service manual for battery removal instructions. **For 2008 and later models:** Refer to the service manual and follow the instructions to remove the ECM caddy from the top of the battery. Disconnect the battery cables, negative (-) cable first.
4. **For ALL models:** Refer to the service manual, and follow the instructions to remove the fuel tank console and fuel tank.

Amplifier Installation

1. Remove the outer fairing and windshield per service manual instructions.

NOTE

- Electrical connectors are identified in the service manual by the numbers and letters shown here **within brackets**.
 - See Figure 1. Make note of the location of the black six-way Deutsch audio to interconnect harness connector [6] (1) before moving the gray Molex 12-way connector [2] (2).
2. Remove the gray Molex 12-way main to interconnect harness connector [2] from the left-side (shifter side) fairing bracket (radio support bracket, 3).



3. See Figure 2. Remove the four socket head screws (1) to release the radio from the left and right radio support brackets (2). Use the oblong holes in the brackets to access the screws, and support the radio as the screws are removed.
4. With the amplifier connector facing the left (shifter) side of the vehicle, place the amplifier into position on top of the radio, with the amplifier brackets outside the radio support brackets.
5. Apply a few drops of Loctite 243 - Blue to the **clean** radio screw threads. Align the threaded inserts in the sides of the radio with the amplifier bracket holes and the oblong holes in the left and right radio support brackets.

NOTE

DO NOT OVERTIGHTEN. Threaded inserts can be easily loosened or cross threaded.

6. Starting at the rear, install the four socket head screws previously removed. Alternately tighten the screws to 4–5.1 N·m (35–45 in-lbs).

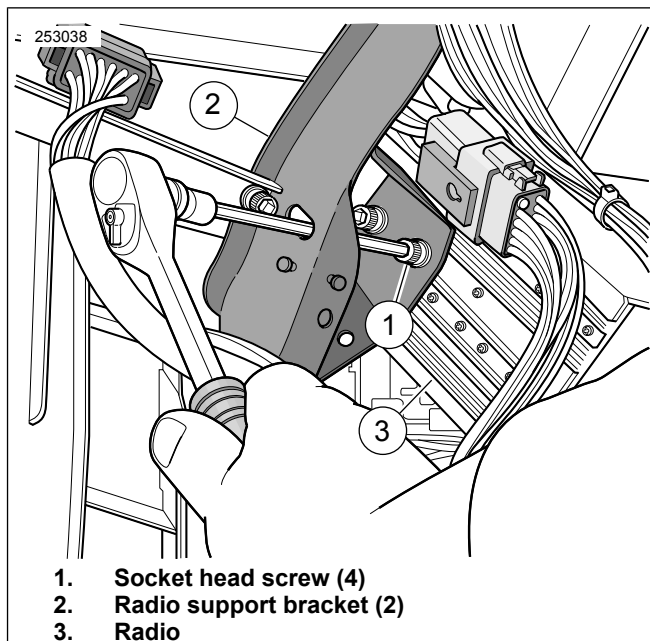

1. Socket head screw (4)
2. Radio support bracket (2)
3. Radio

Figure 2. AM/ FM Radio Installation; Right (Brake) Side Shown

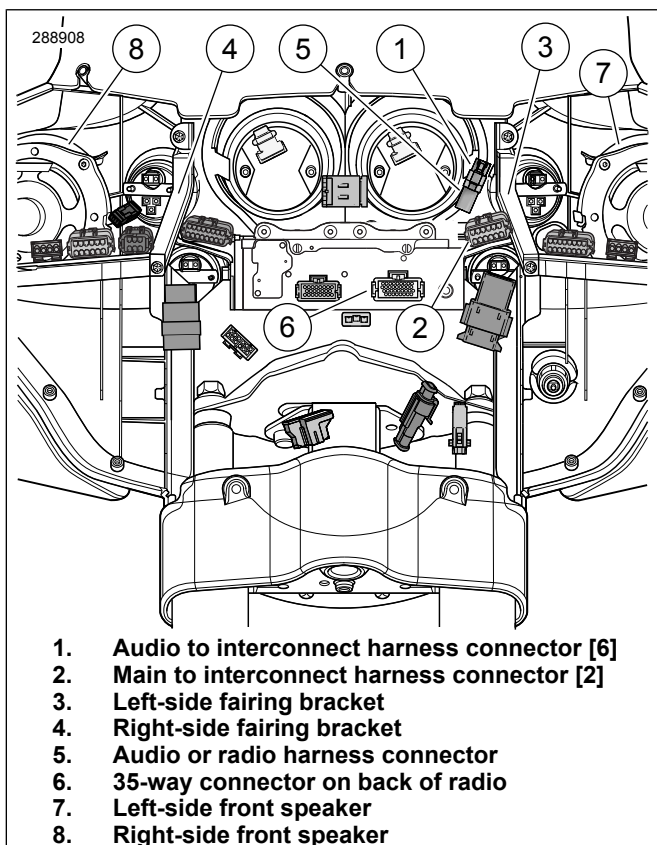

1. Audio to interconnect harness connector [6]
2. Main to interconnect harness connector [2]
3. Left-side fairing bracket
4. Right-side fairing bracket
5. Audio or radio harness connector
6. 35-way connector on back of radio
7. Left-side front speaker
8. Right-side front speaker

Figure 1. Inner Fairing Connectors (FLHX, FLHT/C/U)

Radio Wire Harness Routing and Connection

If the black six-way Deutsch audio to interconnect harness socket housing [6B] (Figure 1, Item 1) on the vehicle is **connected** to an audio harness (5), unplug the connector halves and proceed to the **Amplifier Harness Routing and Connection** section.

If the black six-way housing [6B] is **NOT** connected to a harness, install a radio wire harness (Part No. 69200106, purchased separately) as follows:

1. See Figure 4. Get the amplifier harness (2) from **this** kit.
2. Follow service manual instructions to remove the plugs from cavities 8, 15, 22 and 23 of the 23-way connector (3) on the amplifier harness. Install the terminated wires (15) coming from the two remaining six-way connectors on the radio wire harness to the 23-way connector as follows:
 - Brown wire to cavity 8.
 - White/brown wire to cavity 15.
 - Green wire to cavity 22.
 - Light green/brown wire to cavity 23.
3. Plug the 35-way connector (13) of the radio wire harness (12) into the receptacle on the back of the radio (see Figure 1, Item 6). Listen for a definite "click".
4. Route the shorter branch of the radio wire harness (with a six-way pin housing and yellow/orange and yellow/violet wires), over to the area of socket housing [6B] (1), but **do not** connect at this time. This pin housing (14) will now be known as connector [6A].

Amplifier Harness Routing and Connection

1. Remove the secondary locking wedge from socket housing [6B] (Figure 1, Item 1) on the vehicle per service manual instructions. Remove the plugs from cavities 4 and 5.
2. See Figure 4. Follow service manual instructions to install the **yellow/orange** terminated wire (4) from the amplifier harness into cavity 4 of socket housing [6B] (1), and the **yellow/violet** terminated wire (5) into cavity 5.
3. Install the secondary locking wedge into the socket housing per service manual instructions.
4. Plug the six-way socket housing [6B] into the pin housing [6A] (14) on the radio wire harness (12) installed in the previous section or the vehicle audio harness.
5. Plug the 23-way socket housing (3) into the receptacle on the side of the amplifier. Listen for a definite "click".

NOTE

Two branches of the amplifier harness, each with two socket and two spade terminals, connect to the front speakers.

6. Route the short branch (6) of the amplifier harness (with white/orange and light-green/white wires) **underneath** the left-side fairing support bracket and over to the left-side speaker.

NOTE

For Kit 7600074 only: Install the **new BOOM! Audio High Performance BOOM! Bagger Speakers** per Instruction Sheet J04932 included in this kit.

7. Carefully disconnect the interconnect harness socket terminals from the left-side speaker spade terminals.
8. Install the socket terminals from the amplifier harness to the speaker spade terminals. The spade terminals are different-sized to prevent improper assembly.
9. Install the spade terminals from the amplifier harness to the socket terminals from the interconnect harness. The spade terminals are different-sized to prevent improper assembly.
10. Route the long branch (7) of the amplifier harness (with gray/red and light-green/black wires) to the right-side speaker.
11. Carefully disconnect the interconnect harness socket terminals from the right-side speaker spade terminals.
12. Install the socket terminals from the amplifier harness to the speaker spade terminals. The spade terminals are different-sized to prevent improper assembly.
13. Install the spade terminals from the amplifier harness to the socket terminals from the interconnect harness. The spade terminals are different-sized to prevent improper assembly.

NOTE

See Figure 3. Routing wires and conduit over the amplifier (1) and radio **near the front (headlamp) side (3)** will make installation of the outer fairing (2) difficult due to tight clearance.

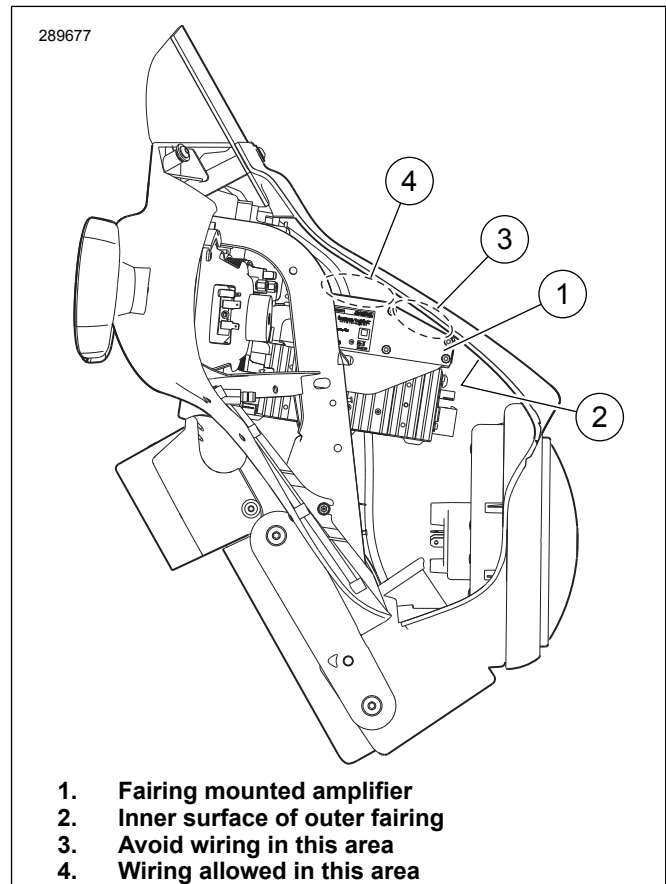

Figure 3. Fairing Mounted Amplifier Wiring Clearances

14. See Figure 4. Use a cable strap from the kit to coil the unconnected wiring (16) of the radio wire harness. Optionally, the brown and white/brown wires and their connector [42A] can provide a signal to an additional left speaker. The green and green/brown wires and their connector [41A] can provide a signal to an additional right speaker.
15. Route the amplifier and radio harnesses rearward along the side of the radio and amplifier or the area above the amplifier nearest the inner fairing (see Figure 3, area 4). Use cable straps from the kit to fasten the amplifier and radio harnesses to existing harnesses inside the fairing.
16. See Figure 4. Route the remaining branch (8) of the amplifier harness rearward on the vehicle to the harness tray. Open the cover of the harness tray. Route the amplifier harness through the openings in the tray, using cable straps to fasten to the main harness.

▲ WARNING

Be sure that steering is smooth and free without interference. Interference with steering could result in loss of vehicle control and death or serious injury. (00371a)

- Be sure wires do not pull tight when handlebars are turned fully to left or right fork stops.
17. Route the harness along the right side of the battery cavity. Bring the red fuse wire (9) and black ground wire (10) into the front of the battery compartment.

Return to Service

NOTE

Verify that the ignition key switch is in the OFF position **before** attaching the battery cables.

⚠ WARNING

Connect positive (+) battery cable first. If positive (+) cable should contact ground with negative (-) cable connected, the resulting sparks can cause a battery explosion, which could result in death or serious injury. (00068a)

1. Connect the battery as follows:
 - a. Install the amplifier harness fused red wire terminal along with the red battery positive (+) cable terminal to the positive (+) side of the battery.
 - b. Install the amplifier harness black ground wire terminal along with the black battery negative (-) cable terminal to the negative (-) side of the battery.
 - c. Apply a light coat of Harley-Davidson electrical contact lubricant (Part No. 99861-02), petroleum jelly or corrosion retardant material to the battery terminals.
 - d. See Figure 4. Tuck the fuse holder (11) and amplifier connecting wires in front of the battery. *NOTE: It may be helpful to cut the cable strap on the strain relief arm of the fuse holder, and install a new cable strap to tie the arm in place after the fuse holder is in position.*
 - e. **For 2006 and 2007 models:** Refer to the service manual and follow the instructions to install the battery into the vehicle. **For 2008 and later models:** Be sure that all wire terminals connected to the battery are aligned with the openings in the ECM caddy. Refer to the service manual and follow the instructions to install the ECM caddy to the top of the battery.

- f. **For ALL models:** Install the main fuse per service manual instructions.

2. Test the sound system for proper operation. If no sound, proceed to **TROUBLESHOOTING**.
3. Upon satisfactory sound system operation, install the outer fairing and windshield per service manual instructions.
4. Disconnect the negative (black) battery cable from the negative (-) battery terminal.
5. Refer to the service manual, and follow the instructions to install the fuel tank and console. Attach the negative battery cable.

⚠ WARNING

After installing seat, pull upward on seat to be sure it is locked in position. While riding, a loose seat can shift causing loss of control, which could result in death or serious injury. (00070b)

6. Refer to the service manual, and follow the instructions to install the seat.

TROUBLESHOOTING

No Sound

1. Verify the wire connections at [6A] and [6B]. Make sure that the yellow/orange wires are installed in cavity 4 of both connector halves, and yellow/violet in cavity 5.
2. At each connector involved in the installation :
 - Make sure all pin and socket terminals are fully seated at the mating face of the connector, and that they have not pushed back upon installation into the mating connection.
 - Gently tug on each wire individually from the rear of the connector to find any that are not seated in their lock.

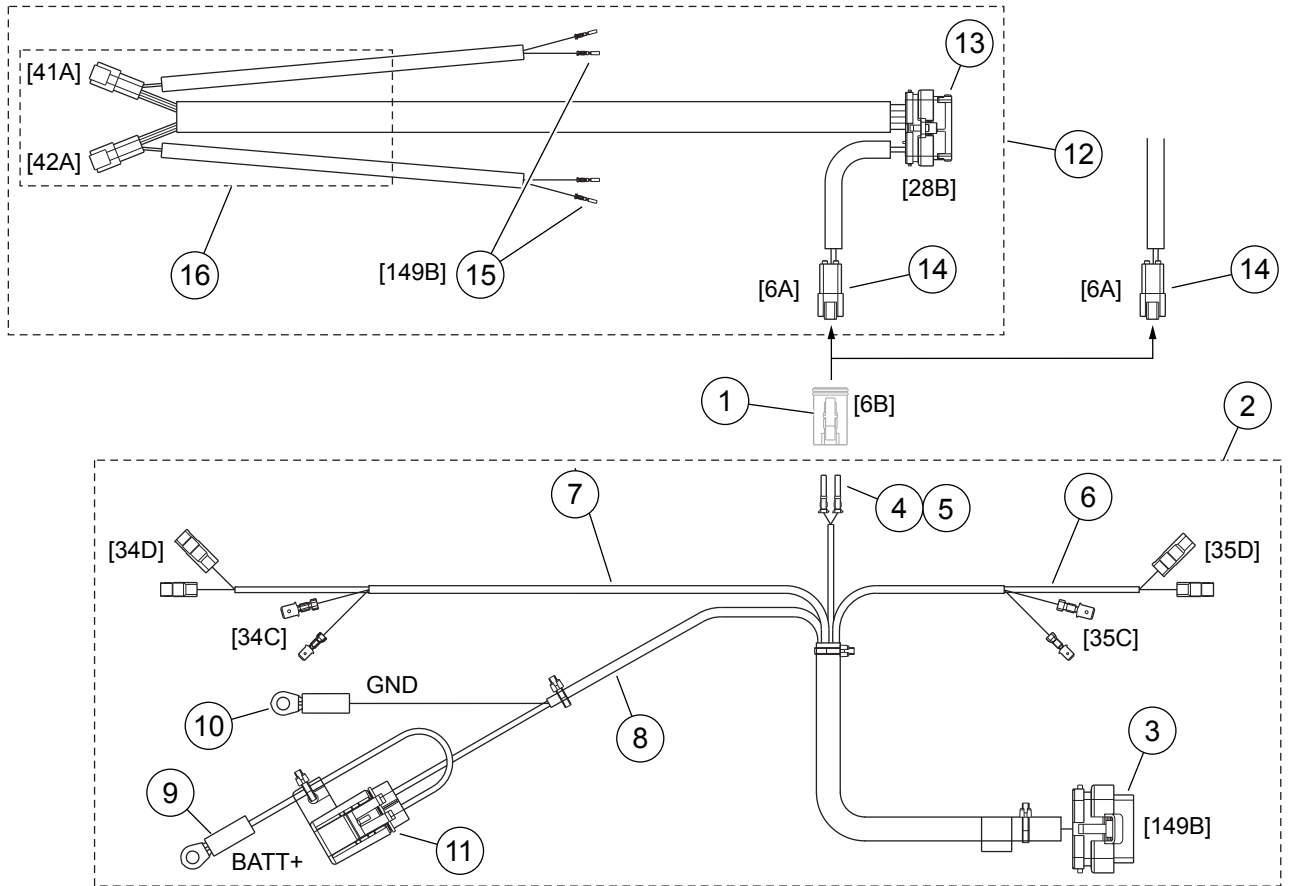

- | | |
|----------------------------------|--|
| 1. Six-way socket housing [6B] | 9. Red wire |
| 2. Amplifier harness | 10. Black wire |
| 3. 23-way connector [149B] | 11. Fuse holder |
| 4. Yellow/orange terminated wire | 12. Radio wire harness |
| 5. Yellow/violet terminated wire | 13. 35-way connector [28B] |
| 6. To left-side speaker | 14. Six-way pin housing [6A] |
| 7. To right-side speaker | 15. Insert into 23-way connector [149B] on amplifier harness |
| 8. Battery branch of harness | 16. Unconnected wiring |

Figure 4. Harness Connection Diagram, Fairing Mounted Amplifier

SERVICE PARTS

is06884

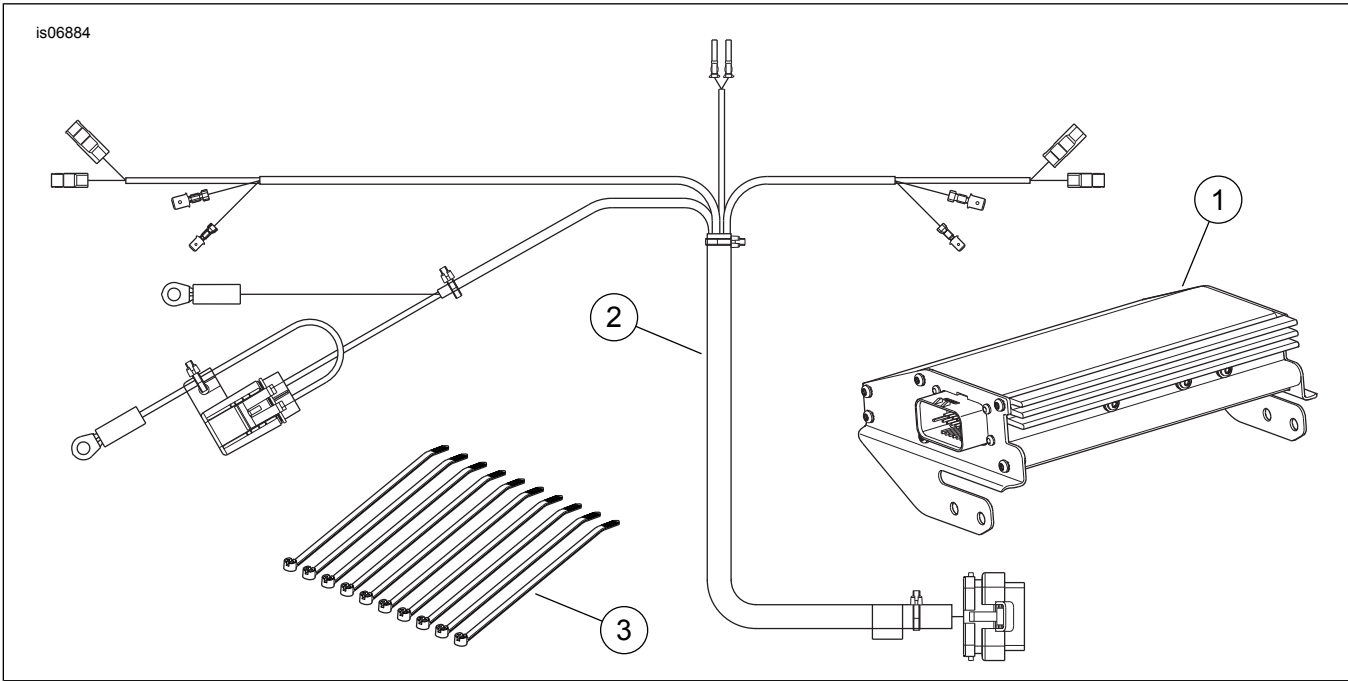

Figure 5. Service Parts, Boom! Audio Amplifier Kit

Table 1. Service Parts

Item	Description (Quantity)	Part Number
1	Amplifier, fairing mounted	76000071
2	Harness, amplifier	Not sold separately
3	Cable strap (10)	Not sold separately
4	For Kit 76000074 only: <ul style="list-style-type: none"> • Two BOOM! Audio High Performance BOOM! Bagger Speakers • Related parts for installation • Instruction Sheet J04932 	