



INSTRUCTIONS

J05205

2014-08-04



FXS, FLS DETACHABLE SADDLEBAG KIT

GENERAL

Kit Number

90200353B, 90200678

Models

For model fitment information, see the P&A retail catalog or the Parts and Accessories section of www.harley-davidson.com (English only).

Additional Parts Required

All models require the separate purchase of a Stop/Tail/Turn Signal (STT) Relocation Kit (Part No. 67800065).

Models equipped with additional detachable accessories (passenger upright, sissy bar, luggage rack) require the separate purchase of a Docking Hardware Kit (Part No. 90200389).

Models WITHOUT additional detachable accessories require the separate purchase of a Docking Hardware Kit (Part No. 90200390).

Models with a side-mount license plate require separate purchase of license plate relocation kit (Part No. 67900127).

Models equipped with a center-mount license plate and fender-mounted reflectors require installation of a red (Part No. 67900223) or amber (Part No. 67900224) reflector kit. Select the appropriate kit based on the color reflector that was previously installed on the fender.

These items are available from a Harley-Davidson dealer.

Tools and Supplies Required

Loctite® 243 Threadlocker and Sealant - Blue (Part No. 99642-97) is required for the proper installation of this kit.

⚠ WARNING

Rider and passenger safety depend upon the correct installation of this kit. Use the appropriate service manual procedures. If the procedure is not within your capabilities or you do not have the correct tools, have a Harley-Davidson dealer perform the installation. Improper installation of this kit could result in death or serious injury. (00333b)

NOTE

This instruction sheet refers to service manual information. A service manual for this year/model motorcycle is required for this installation and is available from a Harley-Davidson dealer.

Kit Contents

See Figure 9 and Table 1.

⚠ WARNING

Federal Motor Vehicle Safety Standard (FMVSS) 108 requires motorcycles to be equipped with rear and side reflectors. Be sure rear and side reflectors are properly mounted. Poor visibility of rider to other motorists can result in death or serious injury. (00336b)

⚠ WARNING

Do not exceed saddlebag weight capacity. Put equal weight in each bag. Too much weight in saddlebags can cause loss of control, which could result in death or serious injury. (00383a)

NOTE

Maximum saddlebag weight capacity is 4.55 kg (10 lb).

License Plate Relocation Kit Installation

1. Perform the license plate relocation kit installation per the instructions in that kit (if required).

STT Relocation Kit Installation

1. Perform the Stop/Tail/Turn Signal (STT) Relocation Kit installation per the instructions in **that** kit, up to the routing of the wiring to the front of the rear fender.
2. **After the wiring has been routed** to the front of the fender, proceed to the **Docking Hardware Installation** section that follows.

Docking Hardware Installation

1. With the rear fender assembly on the work surface, use **new** docking hardware to install the original equipment (OE) fender supports and fender mounting brackets to the fender. **If installing ONLY saddlebags:** Use Docking Hardware Kit Part No. 90200390 (purchased separately). See Figure 10 and Table 2. **If installing saddlebags AND a detachable luggage rack ONLY:** Use Docking Hardware Kit Part No. 90200389 (purchased separately). See Figure 11 and Table 3. **If installing saddlebags AND a detachable passenger upright (sissy bar), WITH OR WITHOUT a detachable luggage rack:** Use Docking Hardware Kit Part No. 90200389 (purchased separately). See Figure 11 and Table 3.
 - a. Get four 3/8-16 x 38 mm (1 1/2 in) long hex socket head screws (3) and docking points (1) from the Docking Hardware Kit.
 - b. See Figure 1. Slip a docking point (1) over the threads of each screw (2).
 - c. Apply a few drops of Loctite 243 - Blue to the last four threads of each screw.



- d. Insert each screw through a hole in a fender support (3), the corresponding hole in the fender (4), and into the fender mounting bracket (5), finger-tight. Tighten the screws to 28.5–36.6 N·m (21–27 ft-lbs).
- e. Get four 3/8-16 x 63.5 mm (2 1/2 in) long hex socket head screws (3), spacers (10) and docking points (1) from the Docking Hardware Kit.
- f. See Figure 1. Slip first a docking point (1), then a spacer (7) over the threads of each screw (6).
- g. Apply a few drops of Loctite 243 - Blue to the last four threads of each screw.
- h. Insert each screw through a hole in a fender support (3), the corresponding hole in the fender (4), and into the fender mounting bracket (5), finger-tight. Tighten the screws to 28.5–36.6 N·m (21–27 ft-lbs).
- i. Get four 3/8-16 x 63.5 mm (2 1/2 in) long hex socket head screws (3) and docking points (1) from Docking Hardware Kit 90200389, and docking points from the passenger upright kit.
- j. See Figure 1. Slip first a docking point (1) from kit 90200389, then an upright kit docking point (8, in the orientation shown) over the threads of each screw (6).
- k. Apply a few drops of Loctite 243 - Blue to the last four threads of each screw.
- l. Insert each screw through a hole in a fender support, the corresponding hole in the fender, and into the fender mounting bracket, finger-tight. Tighten the screws to 28.5–36.6 N·m (21–27 ft-lbs).

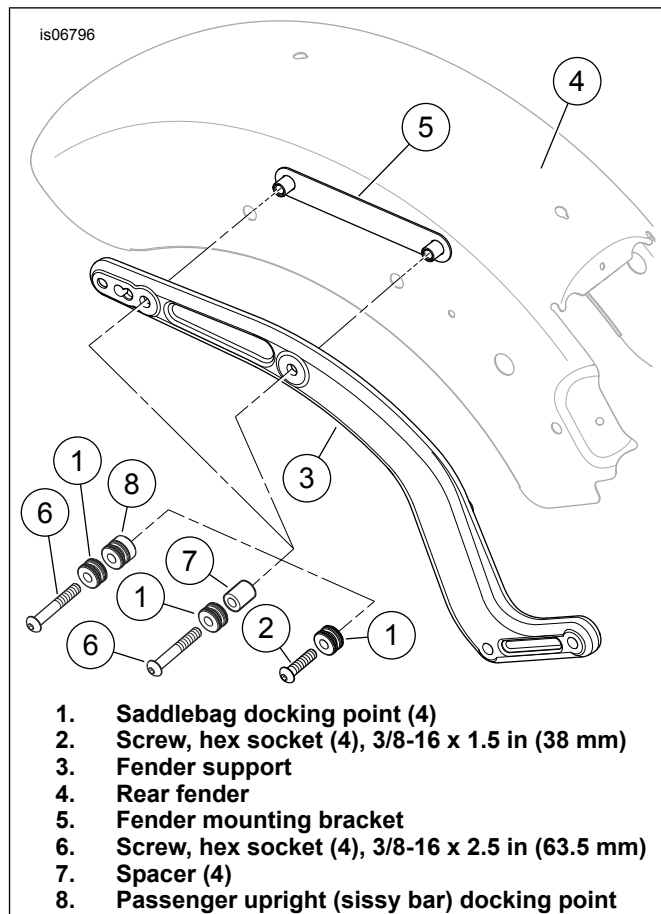

Figure 1. Install FXS Upper Docking Hardware

For ALL installations:

NOTICE

Failure to tighten hardware to the specified torque could result in damage to the installed accessory. (00508b)

2. Install the fender assembly to the vehicle frame per service manual instructions using the four screws and washers removed earlier.
 - a. Tighten the screws initially to 40.7–47.5 N·m (30–35 ft-lbs).
 - b. Loosen all four screws.
 - c. Final-tighten the screws to 51.5–56.9 N·m (38–42 ft-lbs).
3. Follow the instructions in the Turn Signal Relocation Kit to route, connect and secure the STT lamp and license plate illuminator wiring. See **Rear Lamp Wiring Connection to Vehicle**, Step 4.

Saddlebag Support Hardware Assembly and Installation

If installing ONLY saddlebags

Right Lower Support Bracket Assembly:

1. See Figure 2. Get a plain washer (3) and a 5/16-18 x 38.1 mm (1 1/2 in) long TORX® screw (2) from the docking point kit. Install the washer onto the screw threads, and insert the screw through the upper hole in the right lower support bracket (1) as shown.
2. Slip next a docking point (4), then a second plain washer and a lockwasher (5) over the screw threads.
3. Apply a few drops of Loctite 243 - Blue to the last four threads of the screw.
4. Install an acorn nut (6) onto the threads, and tighten to 16.3–24.4 N·m (12–18 ft-lbs).

Left Lower Support Bracket Assembly:

1. See Figure 2. Get a 5/16-18 x 32 mm (1 1/4 in) long hex socket screw (8) from the docking point kit. Slip first a lockwasher (5), then a plain washer (3) and docking point (4) over the screw threads.
2. Apply a few drops of Loctite 243 - Blue to the last four threads of the screw.
3. Install the screw into the threaded hole in the left lower support bracket (7), and tighten to 16.3–24.4 N·m (12–18 ft-lbs).

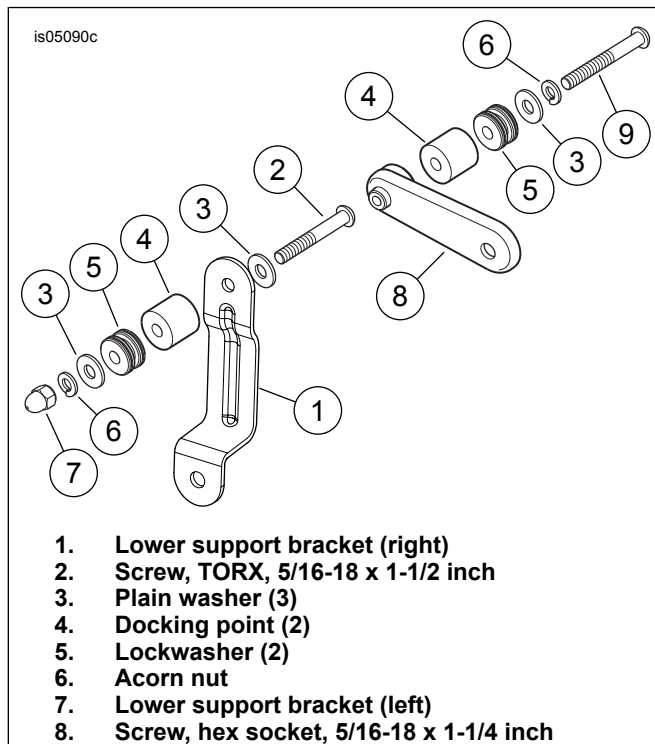

Figure 2. Lower Support Bracket Assembly (Saddlebags Only)

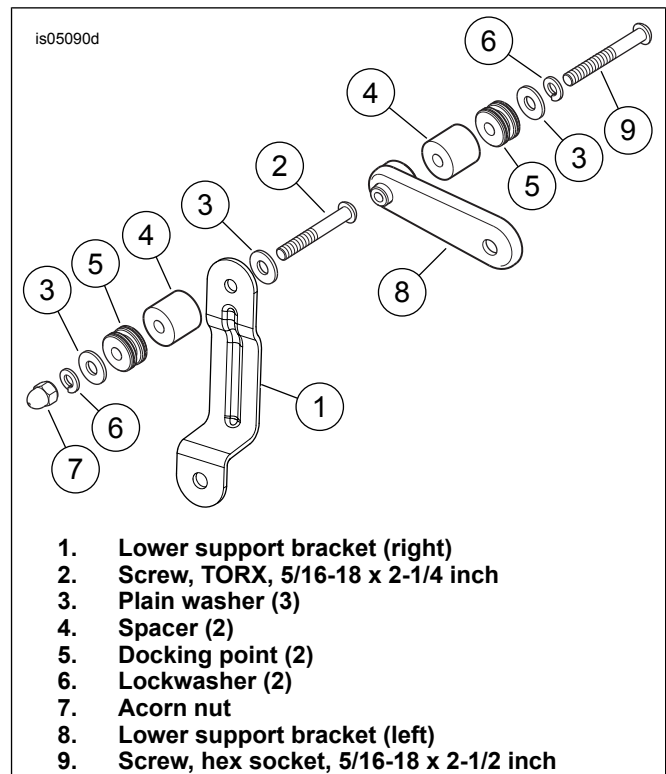

Figure 3. Lower Support Bracket Assembly (Multiple Detachables)

If installing saddlebags AND other detachable accessories

Right Lower Support Bracket Assembly:

1. See Figure 3. Select lower support bracket for your model. Orient the bracket as shown in Figure 2. Get a plain washer (3) and a 5/16-18 x 57.2 mm (2 1/4 in) long TORX screw (2) from the docking point kit. Install the washer onto the screw threads, and insert the screw through the upper hole (smaller hole) in the right lower support bracket (1) as shown.
2. Slip next a thick spacer (4), then a docking point (5), a second plain washer and a lockwasher (6) over the screw threads.
3. Apply a few drops of Loctite 243 - Blue to the last four threads of the screw.
4. Install the acorn nut (7) onto the threads, and tighten to 16.3–24.4 N·m (12–18 ft-lbs).

Left Lower Support Bracket Assembly:

1. See Figure 3. Get a 5/16-18 x 63.5 mm (2 1/2 in) long hex socket screw (9) from the docking point kit. Slip first a lockwasher (6), then a plain washer (3), a docking point (5) and a thick spacer (4) over the screw threads.
2. Apply a few drops of Loctite 243 - Blue to the last four threads of the screw.

3. Install the screw into the threaded hole in the left lower support bracket (8), and tighten to 16.3–24.4 N·m (12–18 ft-lbs).

Lower Support Bracket, Arm and Saddlebag Installation

NOTE

- The lower support brackets will be tightened to specific torques after the brackets are installed and all saddlebag supports are aligned.
- The saddlebag installation procedure that follows must be performed **immediately** following Step 3 to prevent the Loctite from curing before the brackets are tightened to the specified torque. Complete the bracket, arm and saddlebag installation on one side of the vehicle before proceeding to the opposite side.

Lower Support Bracket Installation

1. FXS Models: See Figure 4 or Figure 5. On right hand of the motorcycle, remove the passenger footrest (8) retaining ring (6), clevis pin (3) and spring washer (5).

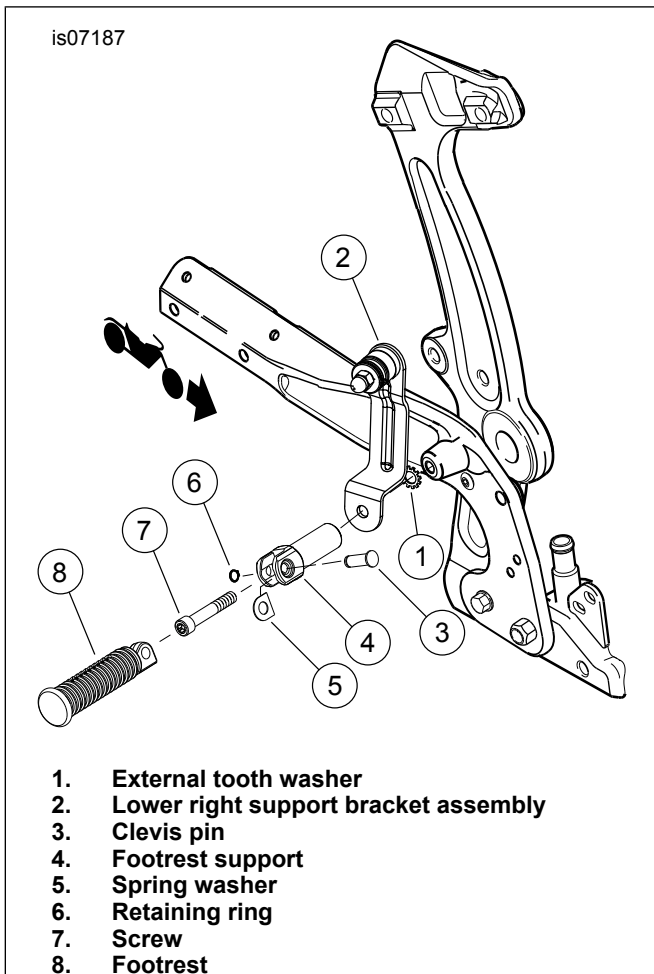

Figure 4. Lower Right Support Bracket Assembly

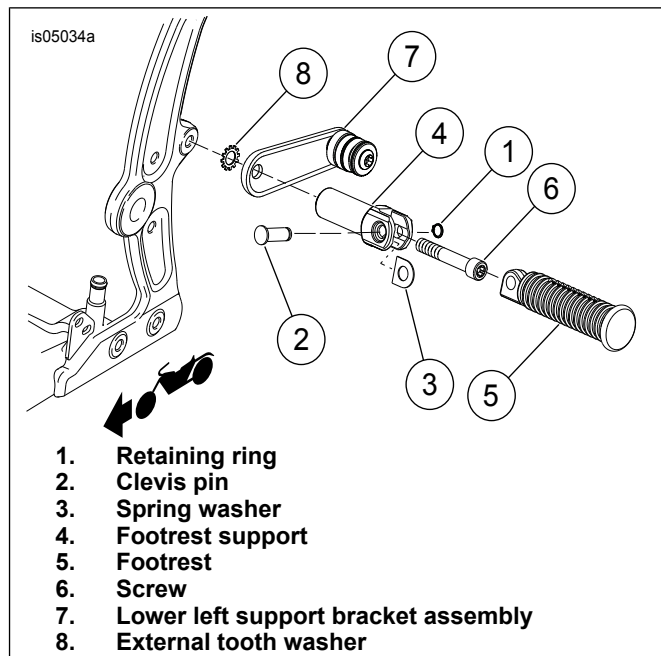

Figure 5. Lower Left Support Bracket Assembly

2. Remove the screw (7) from the frame and footrest support (4), and position the lower support bracket assembly and lockwasher to the footrest tab on the frame.

NOTE

The left-side lower support bracket assembly is installed pointing to the **rear** of the vehicle.

3. Apply a few drops of Loctite 243 - Blue to the screw, and install the footrest support and screw loosely so that the bracket can be repositioned during saddlebag installation if necessary. **Do not** install the footrest at this time.
4. FLS Models: See Figure 6. Install right hand lower support bracket to frame using hex head screw and lockwasher. Tighten screws to 16.3–24.4 N·m (12–18 ft-lbs).
5. See Figure 7. Install left hand lower support bracket to frame using button head screw and lockwasher. Tighten screws to 16.3–24.4 N·m (12–18 ft-lbs).

is07182b

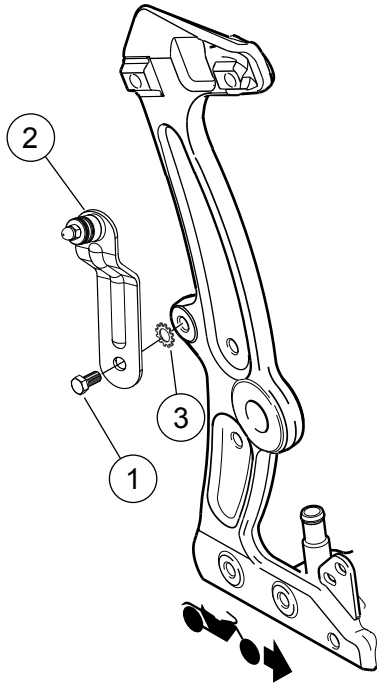

1. Screw, hex head
2. Lower right support bracket assembly
3. External tooth washer

Figure 6. Lower Right Support Bracket Assembly

is07181

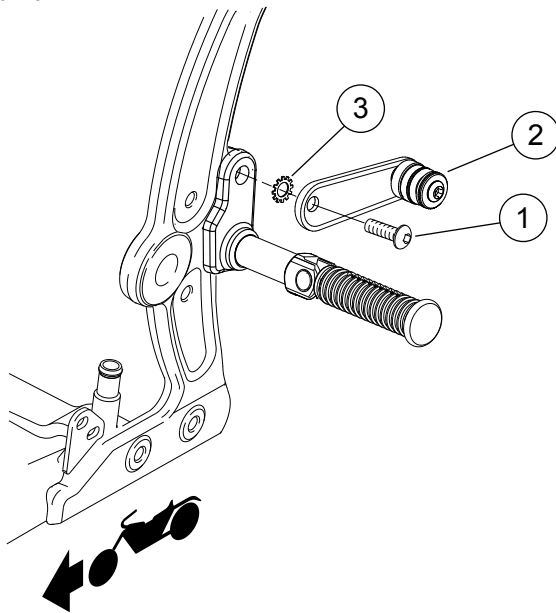

1. Button head screw
2. Lower left support bracket assembly
3. External tooth washer

Figure 7. Lower Left Support Bracket Assembly

Lower Support Arm Installation

1. See Figure 8. Position the lower support arm to the outside of the back of the saddlebag. Apply a few drops of Loctite 243 - Blue to the threads of the screws (2). **Loosely** install the lower support arm (1) to the saddlebag from inside the saddlebag using screws (2), lockwashers (3) and plain washers (4).

Saddlebag Installation

1. Open the saddlebag.
2. See Figure 8. From the inside of the saddlebag pull and rotate the knob (5). The latch pin (6) will release the bracket lock.
3. With the bag tipped forward, swing the large diameter of the keyhole end (7) of the lower support arm over the lower docking point. Swing the body of the bag down so that the outer docking points on the strut cover slide into the slots (8) of the bracket on the back of the bag.
4. Slide the bag forward on the motorcycle making sure that it is fully seated into all three docking points.
5. With the bag as far forward as possible, rotate the knob 1/4 turn. If the bag is seated properly, the knob should pop back in. Look behind the bag and make sure that the latch (6) is in the closed position.
6. Rotate the support bracket (1) so that the lower docking point is fully seated into the smaller diameter of the lower support bracket keyhole. Tighten the footrest support bracket mounting screw to 34–41 N·m (25–30 ft-lbs).
7. If adjusting the support bracket in Step 10 causes the bag or lower support arm to be lifted or pushed down, loosen the three screws (2) holding the lower support arm to the saddlebag and adjust the arm forward or back as needed. Tighten the three support arm screws to 7–10 N·m (60–90 in-lbs).
8. Repeat Steps 1-11 on the opposite side of the vehicle.
9. Follow the Turn Signal Relocation Kit instructions to install cover plates in the original STT lamp locations. See **Rear Lamp Wiring Connection to Vehicle**, Step 11.

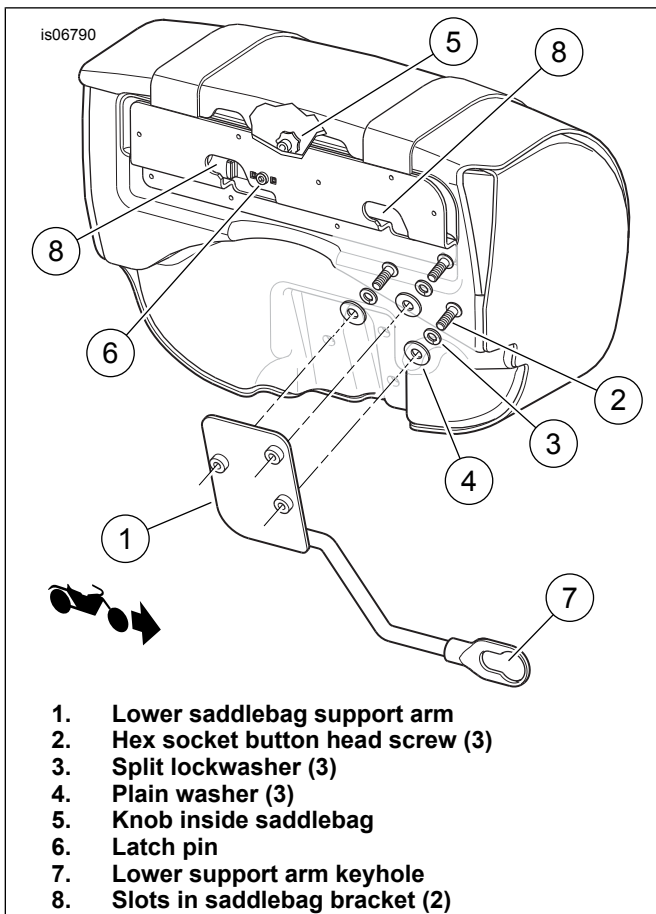

Figure 8. Lower Support Arm Installation (Left Shown)

Final Assembly

NOTE

Verify that the ignition key switch is in the OFF position **before** installing the main fuse.

1. Refer to the service manual and follow the instructions to install the main fuse.

▲ WARNING

After installing seat, pull upward on seat to be sure it is locked in position. While riding, a loose seat can shift causing loss of control, which could result in death or serious injury. (00070b)

2. Refer to the service manual, and follow instructions to install the seat.

MAINTENANCE

Docking Point Screws

NOTICE

Failure to tighten hardware to the specified torque could result in damage to the installed accessory. (00508b)

After 800 km (500 mi) of on road use with the saddlebags installed, it is necessary to check the torque on the docking point mounting screws. Check to make sure the proper torque is maintained and tighten screws if necessary.

- Upper docking point screws, 28.5–36.6 N·m (21–27 ft-lbs).
- Lower front docking point screws, 16.3–24.4 N·m (12–18 ft-lbs).
- Saddlebag lower support arm screws, 6.8–10.2 N·m (60–90 in-lbs).

Saddlebag Docking Points

NOTE

In time, the docking points may wear causing the saddlebag connections to become loose. The fit may be tightened using the following procedure:

1. Remove the docking hardware (screws).
2. Clean threadlocker residue off of the screw threads.
3. Apply Loctite 243 - Blue to the last four threads of the docking point screws.
4. Install the screws loosely for now.
5. Rotate the docking points clockwise approximately 45° from their previous position.
6. Tighten the docking hardware as follows.
 - 28.5–36.6 N·m (21–27 ft-lbs) for upper docking points.
 - 16.3–24.4 N·m (12–18 ft-lbs) for lower front docking points.
7. Repeat as required, up to three adjustments. After the third adjustment, new docking points must be installed.

Saddlebag Care

Apply the Harley-Davidson Genuine Leather Dressing included with the saddlebag according to the instructions in the leather care kit. Additional jars are available from a Harley-Davidson dealer (H-D Part No. 98261-91V).

Saddlebag Snaps

Periodically oil the snaps using a small amount of motor oil or all-purpose household oil.

SERVICE PARTS

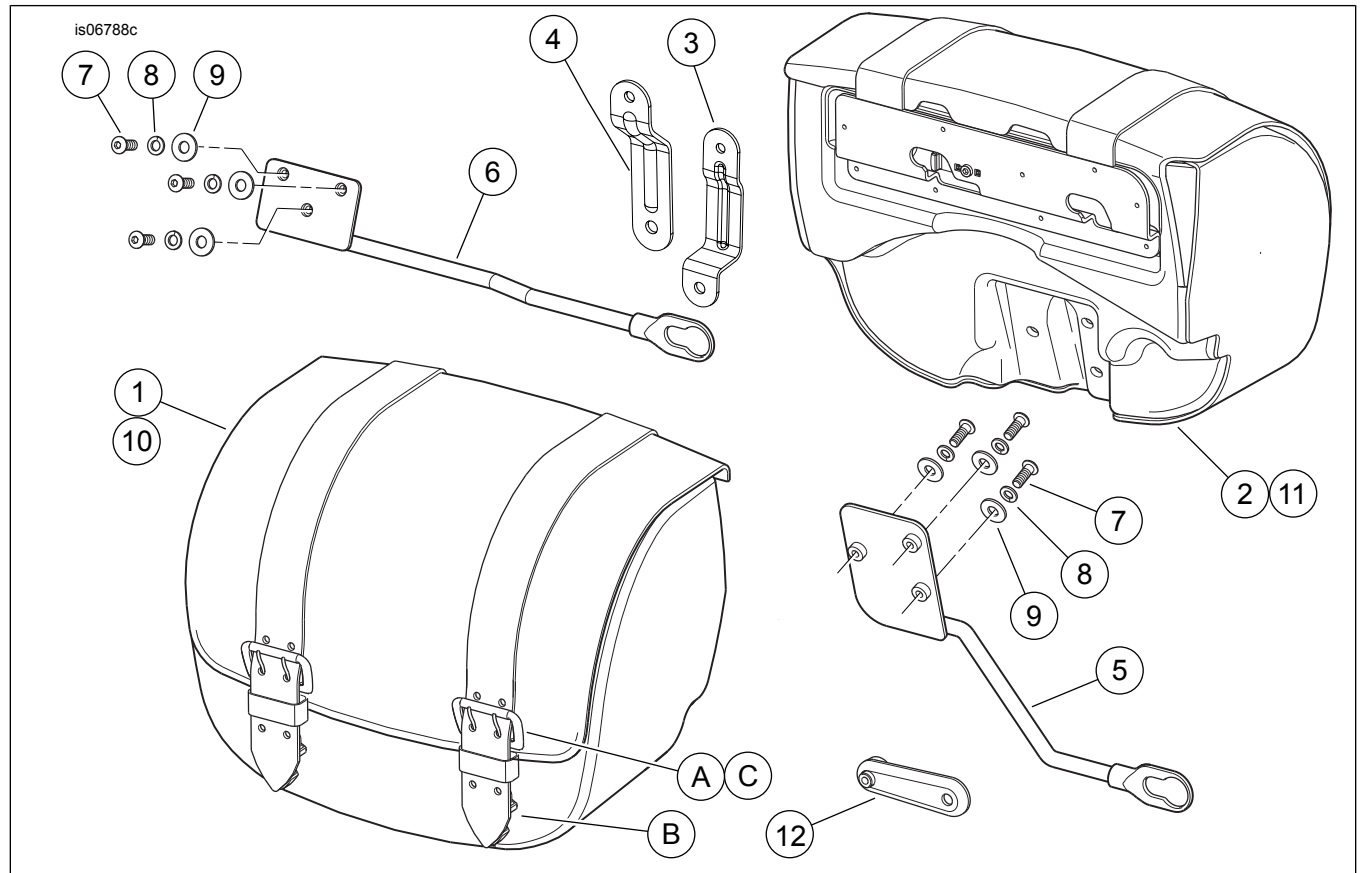

Figure 9. Service Parts, Detachable Saddlebag Kits

Table 1. Service Parts, Detachable Saddlebag Kits

| Item | Description (Quantity) | Part Number |
|--|---|-------------|
| 1 | Saddlebag assembly, right side (Kit 90200353B) | 90200354 |
| 2 | Saddlebag assembly, left side (Kit 90200353B) | 90200355 |
| 3 | Support, saddlebag lower front (left) | 90200708 |
| 4 | Support, saddlebag lower front (right) (FLS models) | 90200762 |
| 5 | Saddlebag support arm, lower left | 90200361 |
| 6 | Saddlebag support arm, lower right | 90200360 |
| 7 | Screw, hex socket button head (6) | 4359 |
| 8 | Lockwasher, split (6) | 7041 |
| 9 | Plain washer (6) | 6333 |
| 10 | Saddlebag assembly, right side (Kit 90200678) | 90200680 |
| 11 | Saddlebag assembly, left side (Kit 90200678) | 90200679 |
| 12 | Support, saddlebag support, lower front (left) (FXS models) | 88300-07 |
| 13 | Screw, hex head (not shown) | 4713W |
| 14 | Lockwasher (2) (not shown) | 7145W |
| 15 | Screw, button head (not shown) | 4163 |
| Service parts for saddlebag assemblies: | | |
| A | Clip, quick-disconnect, male end, with buckle (2) (for Kit 90200353B) | 90200408 |
| B | Clip, quick-disconnect, female end (2) | 88296-07 |
| C | Clip, quick-disconnect, male end, with buckle (2) for kit 90200678 | 90200681 |

SERVICE PARTS

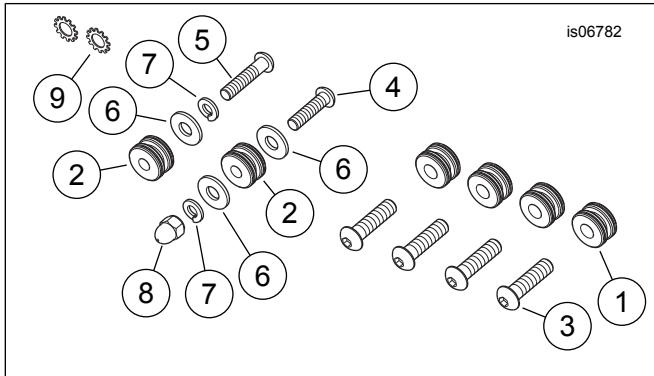

Figure 10. Detachable Docking Hardware Kit 90200390

Table 2. Detachable Docking Hardware Kit 90200390

| Item | Description (Quantity) | Part Number |
|------|---|-------------|
| 1 | Docking point, mini (4), 9.5 mm (3/8 in) ID | 53967-06 |
| 2 | Docking point, mini (2), 7.9 mm (5/16 in) ID | 88229-07 |
| 3 | Screw, hex socket (4), 3/8-16 x 38 mm (1 1/2 in) long | 4127 |
| 4 | Screw, hex socket, 5/16-18 x 32 mm (1 1/4 in) long | 4219 |
| 5 | Screw, TORX button head, 5/16-18 x 38 mm (1 1/2 in) long | 4784 |
| 6 | Plain washer (3), 8 mm (5/16 in) ID | 6333 |
| 7 | Lockwasher, split (2), 8 mm (5/16 in) ID | 7041 |
| 8 | Acorn nut, 5/16-18 | 94006-90T |
| 9 | Lockwasher, external tooth (2), 9.5 mm (3/8 in) ID | 7145W |

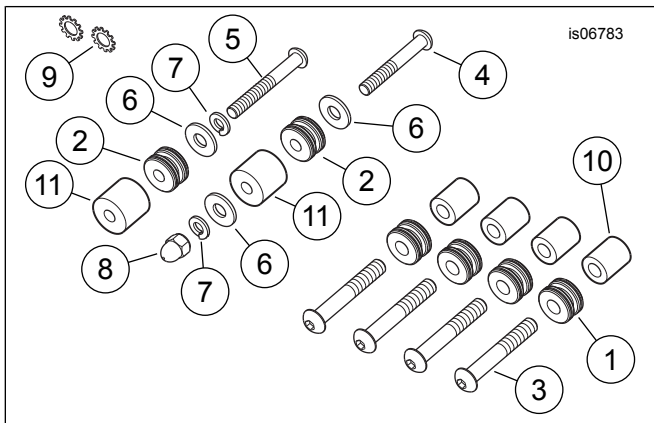

Figure 11. Detachable Docking Hardware Kit 90200389

Table 3. Detachable Docking Hardware Kit 90200389

| Item | Description (Quantity) | Part Number |
|------|---|------------------------|
| 1 | Docking point, mini (4), 9.5 mm (3/8 in) ID | 53967-06 |
| 2 | Docking point, mini (2), 7.9 mm (5/16 in) ID | 88229-07 |
| 3 | Screw, hex socket (4), 3/8-16 x 63.5 mm (2 1/2 in) long | Not sold separately |
| 4 | Screw, TORX button head, chrome, 5/16-18 x 57 mm (2 1/4 in) long | 4184 |
| 5 | Screw, hex socket, 5/16-18 x 63.5 mm (2 1/2 in) long | 3584 |

Table 3. Detachable Docking Hardware Kit 90200389

| Item | Description (Quantity) | Part Number |
|------|---|------------------------|
| 6 | Plain washer (3), 8 mm (5/16 in) ID | 6333 |
| 7 | Lockwasher, split (2), 8 mm (5/16 in) ID | 7041 |
| 8 | Acorn nut, 5/16-18 | 94006-90T |
| 9 | Lockwasher, external tooth (2), 9.5 mm (3/8 in) ID | 7145W |
| 10 | Spacer, 9.5 mm (3/8 in) ID (4) | 40950-98A |
| 11 | Spacer, 7.9 mm (5/16 in) ID (2) | Not sold separately |