



INSTRUCTIONS

J04814

2011-05-13



FRONT ROULETTE WHEEL KITS

GENERAL

⚠ WARNING

Install only wheels and installation kits approved for your model motorcycle. Contact a Harley-Davidson dealer to verify fitment. Mismatching wheels and installation kits or installing wheels not approved for your model can cause loss of control, which could result in death or serious injury. (00610c)

Kit Numbers

42171-09, 55065-10, 43300116

Models

For model fitment information, see the P&A Catalog or the Parts and Accessories section of www.harley-davidson.com (English only).

NOTE

Accessory hub caps are not compatible with this wheel.

Kit Contents

See the Service Parts section for kit contents.

Additional Parts Required

- Wheel Installation Kit (See Table 2 and Table 3 to determine required installation kit.)
- 10 Brake Disc/Hub Cap Screws (3655A) or 2 Chrome screw kits (46646-05)
- Wheel Bearing Remover and Installer (94134-09)

The following Harley-Davidson Genuine Motor Accessories are recommended for proper maintenance and cleaning:

- Harley® Bright™ Chrome Cleaner (94683-99) (Not for use on kit 43300116)
- Harley® Glaze™ Polish and Sealant (99701-84)
- Harley® Wheel and Spoke Brush (43078-99)
- Harley-Davidson® Wheel and Tire Cleaner (94658-98)
- Harley® Preserve™ Bare Aluminum Protectant (99845-07)

⚠ WARNING

Rider and passenger safety depend upon the correct installation of this kit. Use the appropriate service manual procedures. If the procedure is not within your capabilities or you do not have the correct tools, have a Harley-Davidson dealer perform the installation. Improper installation of this kit could result in death or serious injury. (00333b)

NOTE

This instruction sheet references service manual information. A service manual for your model motorcycle is required for this installation and is available from a Harley-Davidson dealer.

INSTALLATION

NOTE

Use plastic protectors on tire mounting tools and rim clamps when mounting a tire to a painted wheel.

When mounting tires, liberally use tire lube on the wheel and tire.

For tire removal, use plastic inserts between the rim and tire after breaking the bead to create a large enough gap for the rim clamps to get into.

1. Remove existing front wheel assembly. Save axle, axle nut, brake disc, and wheel spacers for kit installation. Refer to FRONT WHEEL in service manual.

NOTE

Install long valve stem (43206-01) included in the installation kit. Discard all other valve stems.

2. See Figure 1. Install valve stem assembly (M) on wheel. Refer to TIRES in service manual.

NOTE

Install the primary bearing first using appropriate service manual and WHEEL BEARING REMOVER/INSTALLER.

The side with the machined groove on the hub face is the primary bearing side.

Install the wheel so that the hub markings are on the right side and the machined groove is on the left side of the motorcycle.

If the wheel has a yellow dot sticker on the rim, orient the tire so the white dot is opposite of the sticker. If the wheel has a green dot sticker on the rim, orient the tire so the white dot is aligned with the sticker. If no rim dot sticker is present, see the service manual.

NOTICE

Do not re-use brake disc/rotor screws. Re-using these screws can result in torque loss and damage to brake components. (00319c)

3. Install front wheel (1), stock axle and stock axle nut. Refer to FRONT WHEEL in service manual.



MAINTENANCE AND CLEANING

Chrome parts must be maintained regularly so that they keep their original shine and luster.

1. Clean heavily-soiled wheel surfaces using Harley-Davidson Wheel and Tire Cleaner, applied with Harley Wheel and Spoke Brush.

2. Thoroughly clean chrome with a good quality chrome cleaner, such as Harley Bright Chrome Cleaner.
3. After cleaning and polishing, seal the finish with a good quality sealer, such as Harley Glaze Polish and Sealant.

SERVICE PARTS

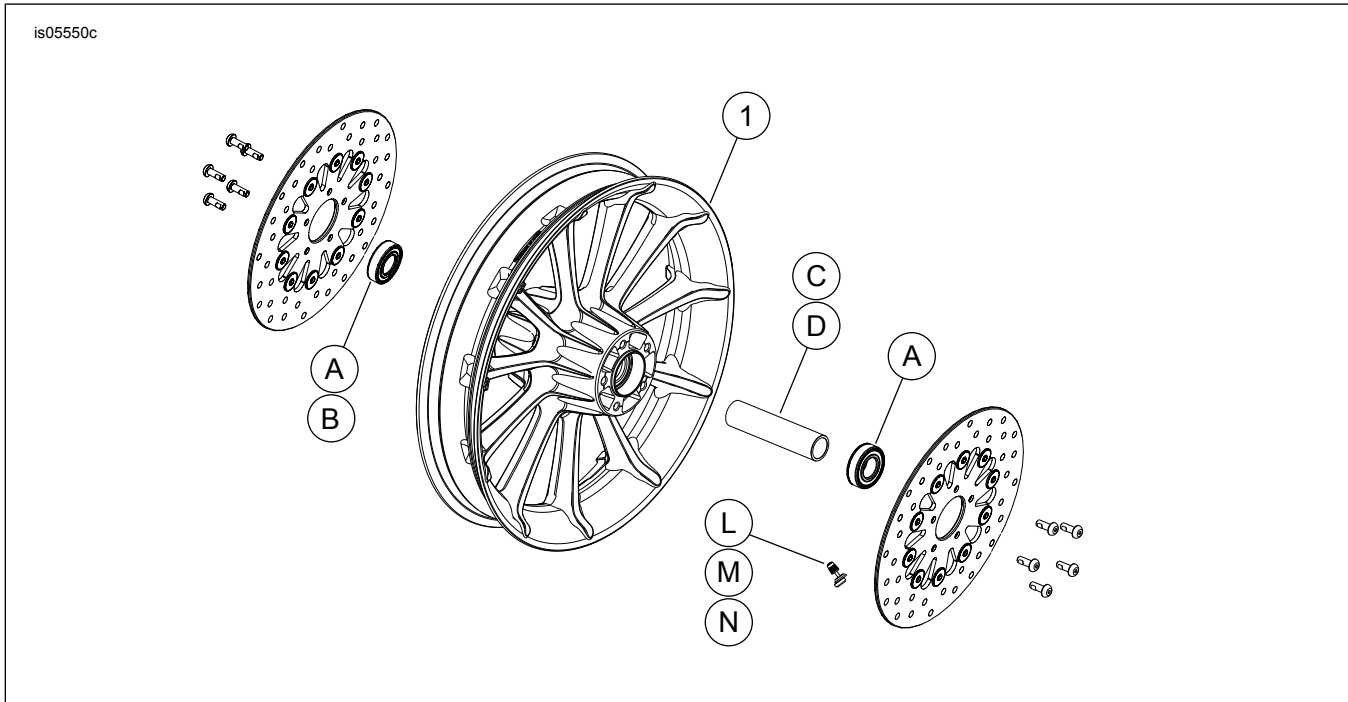

Figure 1. Service Parts: Roulette Wheel Kits

Table 1. Service Parts and Wheel Kit Contents

Kit	Item	Description (Quantity)	Part Number
42171-09, 55065-10, 43300116	1	Wheel	Not Sold Separately

Table 2. FRONT 25 mm Bearing Wheel Installation Kit (41455-08C)

FRONT 25 mm Bearing Wheel Installation Kit (41455-08C)		ITEM (Quantity Used and Description)							
Fitment	Wheel Size	A	C	D	J	K	L	M	N
2008 Touring; 2009 and later FLHRC (non-ABS) and Trike (non-ABS)	16 x 3.0 in	2	0	1	0	1	*	*	*
2009 and later Touring (non-ABS)	17 x 3.0 in	2	0	1	0	0	*	*	*
2008 and later Touring (non-ABS)	18 x 3.5 in	2	0	1	0	**	*	*	*
2008 and later Dyna (except FXDWG and FXDF)	19 x 2.5 in	2	1	0	**	0	*	*	0
2008 and later VRSCAW, VRSCD, VRSCF and VRSCDX (non-ABS)	19 x 3.0 in	2	1	0	**	0	*	*	0
2009 and later Touring (non-ABS)	19 x 3.5 in	2	0	1	0	0	*	*	*
Installation kits are designed to work with many different wheel styles and fitments. Contact a Harley-Davidson dealer to verify that the wheel and installation kits are both designed and approved for the motorcycle they are being installed on.		A	Bearing, regular (2)		9276				
NOTES:		C	Axle sleeve		41748-08				
* See NOTE above valve installation step in INSTALLATION to determine which valve stem to use for your particular kit. Discard other valve stem(s).		D	Axle sleeve		41900-08				
** See NOTES for your wheel kit above the wheel assembly step in INSTALLATION to determine if bearing shim is used for your particular wheel kit and fitment.		J	Bearing shim***		41450-08				
*** Bearing shim installed under the primary bearing.		K	Bearing shim***		43903-08				
		L	Valve stem, short		43157-83A				
		M	Valve stem, long		43206-01				
		N	Valve stem, pull thru		40999-87				

Table 3. FRONT 25 mm Bearing ABS Wheel Installation Kit (41454-08B)

FRONT 25 mm Bearing ABS Wheel Installation Kit (41454-08B)		ITEM (Quantity Used and Description)								
Fitment	Wheel Size	A	B	C	D	J	K	L	M	N
2008 Touring and 2009 and later FLHRC with ABS	16 x 3.0 in	1	1	0	1	0	1	*	*	0
2009 and later Touring with ABS	17 x 3.0 in	1	1	0	1	0	0	*	*	*
2008 and later Touring with ABS	18 x 3.5 in	1	1	0	1	**	**	*	*	*
2008 and later VRSCAW, VRSCD, VRSCF and VRSCDX with ABS	19 x 3.0 in	1	1	1	0	**	**	*	*	0
2009 and later Touring with ABS	19 x 3.5 in	1	1	0	1	0	0	*	*	*
Installation kits are designed to work with many different wheel styles and fitments. Contact a Harley-Davidson dealer to verify that the wheel and installation kits are both designed and approved for the motorcycle they are being installed on. NOTES: * See <i>NOTE</i> above valve installation step in INSTALLATION to determine which valve stem to use for your particular kit. Discard other valve stem(s). ** See <i>NOTES</i> for your wheel kit above the wheel assembly step in INSTALLATION to determine which bearing shim to use for your particular wheel kit and fitment. *** Red side of bearing must be installed toward the wheel. The ABS bearing is primary. **** Bearing shim installed under the primary bearing.	A	Bearing, regular							9276	
	B	Bearing, ABS***							9252	
	C	Axle sleeve							41748-08	
	D	Axle sleeve							41900-08	
	J	Bearing shim****							41450-08	
	K	Bearing shim****							43903-08	
	L	Valve stem, short							43157-83A	
	M	Valve stem, long							43206-01	
N	Valve stem, pull thru							40999-87		