



INSTRUCTIONS

J05275

2015-06-22



SCREAMIN' EAGLE STAGE 1 KIT FOR EFI XL MODELS

GENERAL

Kit Number

29000009 (black), 29000019 (chrome)

Models

For model fitment information, See the P&A Retail Catalog or the Parts and Accessories section of www.harley-davidson.com (English only).

Installation Requirements

Proper installation of this kit requires the use of Digital Technician™ at a Harley-Davidson dealer.

Loctite® 243 (Blue) 0.5 ml packet (Part Number 99642-97)

⚠ WARNING

Rider and passenger safety depend upon the correct installation of this kit. Use the appropriate service manual procedures. If the procedure is not within your capabilities or you do not have the correct tools, have a Harley-Davidson dealer perform the installation. Improper installation of this kit could result in death or serious injury. (00333b)

NOTE

This instruction sheet references service manual information. A service manual for your model motorcycle is required for this installation and is available from a Harley-Davidson Dealer.

Kit Contents

See Figure 1 and Table 1.

NOTE

Installation of this kit by an authorized Harley-Davidson dealer will not impact your limited vehicle warranty.

This Stage 1 kit is intended for High Performance applications only. This engine related performance part is legal for sale or use in California on pollution controlled motor vehicles. Engine related performance parts are intended for the experienced rider only.

The air cleaner contained in this kit is designed to perform with this kit only. Any other combination of components is not confirmed to be legal for street use.

REMOVAL

⚠ WARNING

To prevent accidental vehicle start-up, which could cause death or serious injury, disconnect battery cables (negative (-) cable first) before proceeding. (00307a)

⚠ WARNING

Disconnect negative (-) battery cable first. If positive (+) cable should contact ground with negative (-) cable connected, the resulting sparks can cause a battery explosion, which could result in death or serious injury. (00049a)

1. Disconnect battery cables, negative (-) cable first.
2. Remove existing air cleaner backplate. Refer to AIR CLEANER: EFI, REMOVAL in service manual. Save stock air cleaner cover, button head screw that secures cover, and two breather screws removed from backplate. Discard remaining parts.

INSTALLATION

Install Air Cleaner

⚠ WARNING

The element in this kit is specifically designed for use with the OE (original equipment) cover. Using this kit with an air cleaner cover other than the OE cover could lead to failure of the element faceplate. The kit may be used in conjunction with other H-D accessory covers provided the appropriate adapter recommended in those kits is used. If the element faceplate fails the cover could detach possibly distracting the rider which could result in death or serious injury. (00400b)

NOTE

When servicing the air cleaner, apply Loctite® 243 (blue) 99642-97 to threads of all fasteners.

1. See Figure 1. Install two O-rings (1) from kit in grooves around breather screw holes on induction module side of backplate assembly (2).
2. Align the holes of gasket (3) and install on induction module side of backplate.
3. Insert breather screws (8) through the backplate.
4. Thread screws into cylinder head but do not tighten.
5. Thread air cleaner mounting studs (4) all the way through the backplate (2) and gasket (3) until the screw threads are captured in induction module. Do not tighten completely at this time.
6. Alternately tighten two breather screws (8) to 13.6–16.3 N·m (120–144 in-lbs).
7. Press breather plugs (5) into breather screw cavities, aligning tubes with recesses in backplate.



8. Tighten three air cleaner studs (4) to 6.2–6.8 N·m (55–60 in-lbs).

Install Air Cleaner Element and Cover

NOTE

This is a dry air filter. Do not apply oil to the filter element.

Whenever the air cleaner cover is installed, apply Loctite 243 (blue) to the air cleaner cover screw.

1. See Figure 1. Secure air filter element (7) to air cleaner mounting studs (4) using screws (6). Tighten screws to 6.2–6.8 N·m (55–60 in-lbs).
2. Apply Loctite 243 (blue) to threads of air cleaner cover screw (B). Secure air cleaner cover (A) to air filter element (7) with screw.
3. Align air cleaner cover horizontally for best appearance, then tighten screw securely. Tighten to 4.1–6.8 N·m (36–60 in-lbs).

Final Assembly

⚠ WARNING

Connect positive (+) battery cable first. If positive (+) cable should contact ground with negative (-) cable connected, the resulting sparks can cause a battery explosion, which could result in death or serious injury. (00068a)

1. Install battery cables using service manual instructions.

⚠ WARNING

After installing seat, pull upward on seat to be sure it is locked in position. While riding, a loose seat can shift causing loss of control, which could result in death or serious injury. (00070b)

2. Install seat using service manual instructions.

Recalibrate ECM

NOTICE

You must recalibrate the ECM when installing this kit. Failure to properly recalibrate the ECM can result in severe engine damage. (00399b)

Download the new ECM calibration using the Digital Technician[®] at a Harley-Davidson dealer.

MAINTENANCE

Air Cleaner Element Maintenance

NOTE

This is a dry air filter. Do not apply oil to the filter element.

When servicing the air cleaner, apply Loctite 243 (blue) to threads of all fasteners.

1. See Figure 1. Remove air cleaner cover (A) and inspect the filter element (7) every 5000 mi (8000 km), or more often under dusty conditions.
2. Clean filter element as follows:
 - a. Remove and wash element by immersing it, on edge, in a shallow pan containing enough Air Cleaner/Degreaser to cover *no more* than 3/4 the depth of the filter pleats. *Do not let dirty solution get inside the element.* Carefully "roll" the element in the solution around its perimeter until the entire outer surface of the filter pleats has been soaked.
 - b. Remove filter element from cleaner/degreaser and allow five minutes for the cleaner to dissolve the dirt.
 - c. From the inside out, rinse the element with cold water. Shake off excess water, and allow the element to air dry. *Do not dry with compressed air.*
3. Install air cleaner element and cover.

SERVICE PARTS

is08633

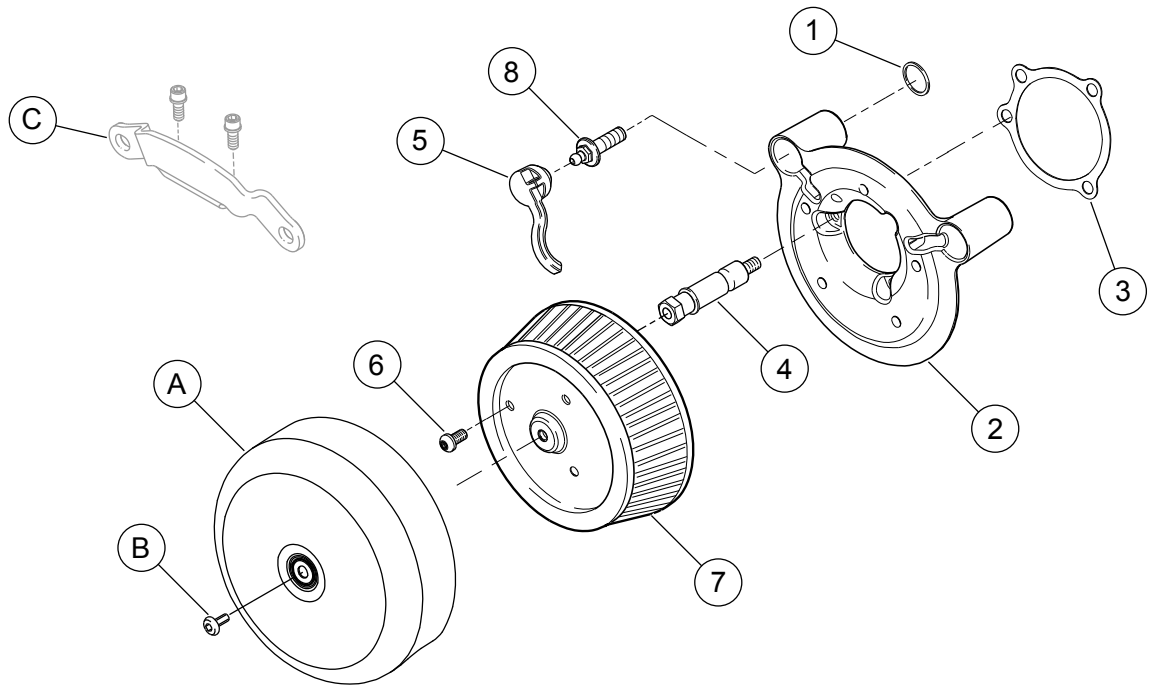

Figure 1. Service Parts: Screamin' Eagle Stage 1 Kit

Table 1. Service Parts: Screamin' Eagle Stage 1 Kit

Item	Description (Quantity)	Part Number
1	O-ring (2)	11292
2	Backplate assembly, black or chrome	Not Sold Separately
3	Gasket, backplate	29059-88A
4	Stud, air cleaner (3)	29447-99A
5	Plug, breather (2)	29557-05
6	Screw, air cleaner element (3)	3652
7	Filter element	29442-99E
8	Breather screw (2)	29400001
9	Product information label (Not Shown)	Not Sold Separately
Items mentioned in text, but not included in kit:		
A	Air cleaner cover	
B	Screw	
C	Induction module bracket (remove and discard)	