



INSTRUCTIONS

J05408

2012-02-27



CUSTOM TOURING AUDIO SYSTEM

GENERAL

It is **strongly advised** that this kit be installed by an authorized Harley-Davidson dealer.

Kit Number

76000209

Models

For model fitment information, see the P&A retail catalog or the Parts and Accessories section of www.harley-davidson.com (English only).

NOTE

The amplifiers and speakers in this kit are part of a system that has an impedance of one Ohm, and are for use ONLY with the Custom Touring Audio System and Advanced Audio AM/FM/CD radio on select fitments. See the P&A retail catalog or the Parts and Accessories section of www.harley-davidson.com (English only).

*Using these speakers on 2005 or earlier Harley-Davidson audio systems **WILL cause permanent damage** to those systems.*

Installation Requirements

Proper installation of this kit requires separate purchase and installation of Harley-Davidson VENTED fairing lowers (or replacement if the vehicle currently has NON-VENTED lowers). See the P&A retail catalog or the Parts and Accessories section of www.harley-davidson.com (English only).

Replacement of saddlebag lids is required.

A drill template (Part No. 76000265, purchased separately) is available for easier drilling of the inboard saddlebag wall. **If used with Twin Rail Chrome Saddlebag Guard Kit** (Part No. 90862-09 or 91216-97), the drill template **must be used** instead of following the instructions under **Saddlebag Drilling** and shown in Figure 5.

These items are available from a Harley-Davidson dealer.

RTV sealant is required for proper installation of this kit.

If the vehicle is CURRENTLY EQUIPPED with fairing lowers, two rubber washers (Part No. 7415A) will be needed.

NOTE

The purchase of this kit entitles you to a specially developed sound equalization software that is used in conjunction with the Advanced Audio system. This unique equalization was designed to optimize the performance and sound response of the speakers.

*Even if this kit is not being installed by a Harley-Davidson dealer, this special equalization **software** is available without charge from any dealer through Digital Technician II. Dealer labor rates may apply for the upgrade procedure.*

⚠ WARNING

Rider and passenger safety depend upon the correct installation of this kit. Use the appropriate service manual procedures. If the procedure is not within your capabilities or you do not have the correct tools, have a Harley-Davidson dealer perform the installation. Improper installation of this kit could result in death or serious injury. (00333b)

NOTE

This instruction sheet refers to service manual information. A service manual for this year/model motorcycle is required for this installation. In addition, a model year 2012 or later FLHXSE service manual supplement is recommended. Both are available from a Harley-Davidson dealer.

Electrical Overload

NOTICE

It is possible to overload the vehicle's charging system by adding too many electrical accessories. If the combined electrical accessories operating at any one time consume more electrical current than the vehicle's charging system can produce, the electrical consumption can discharge the battery and cause damage to the vehicle's electrical system. (00211d)

⚠ WARNING

When installing any electrical accessory, be certain not to exceed the maximum amperage rating of the fuse or circuit breaker protecting the affected circuit being modified. Exceeding the maximum amperage can lead to electrical failures, which could result in death or serious injury. (00310a)

The Custom Touring Audio System requires up to **16 Amps** of additional current from the electrical system.

Kit Contents

See Figure 9, Figure 10, Table 2, Figure 11 and Table 3 for front-of vehicle components.

See Figure 12, Table 4 and Table 5 for rear-of vehicle components.

PREPARATION

NOTE

For vehicles equipped with security siren:

- **2007 and later:** Verify that the Hands-Free Fob is present. Turn the ignition key switch to IGNITION.
- **2006:** Disarm the siren with the key fob.



▲ WARNING

To prevent spray of fuel, purge system of high-pressure fuel before supply line is disconnected. Gasoline is extremely flammable and highly explosive, which could result in death or serious injury. (00275a)

1. Follow service manual instructions to purge the fuel supply of high pressure gasoline and remove the fuel supply line.

▲ WARNING

To prevent accidental vehicle start-up, which could cause death or serious injury, remove main fuse before proceeding. (00251b)

2. Refer to the service manual and follow instructions to remove the main fuse.
3. Remove the seat. Retain all seat mounting hardware.

▲ WARNING

When servicing the fuel system, do not smoke or allow open flame or sparks in the vicinity. Gasoline is extremely flammable and highly explosive, which could result in death or serious injury. (00330a)

4. Follow the instructions in the service manual to remove the instrument console (if equipped) from the fuel tank.
5. See the service manual for fuel tank removal instructions.
6. Release the catches on the wire trough cover and remove the cover.

NOTE

Models *WITHOUT* fairing lowers or models with *NON-VENTED* fairing lowers will require separate purchase of *VENTED* lowers.

7. **Models Equipped With Fairing Lowers:** Remove the lower fairings per service manual instructions. Discard the rubber washers at the bottom of the fairings.
8. **ALL Models:** Follow service manual instructions to remove the outer fairing and windshield.

FAIRING SPEAKER INSTALLATION

Remove and Replace Upper Fairing Speakers

1. Remove the original equipment (OE) speakers from the inner fairing per service manual instructions.

NOTE

Do not connect the vehicle harness to the speaker spade contacts at this time.

2. See Figure 9. Follow the service manual and use the **new** screws (2) from the kit to install the **new** 133 mm (5.25 in) diameter speakers (1) into the inner fairing. Tighten the screws to 1.8–2 N·m (16–18 **in-lbs**).

Remove and Relocate Auxiliary Gauges

NOTE

- The following sections describe the suggested arrangement; Removal of the air temperature and oil pressure gauges (if present) from the vehicle, relocation of the fuel gauge and volt meter to the lower positions, and installation of new tweeters in the two upper auxiliary gauge positions. However, the tweeters and **any** two of the four gauges can be installed into any position as desired.
- Electrical connectors are identified in the service manual by the numbers and letters shown here **within brackets**.

1. **If no lower gauges:** Remove the plastic plugs from the lower holes in the inner fairing. **With lower gauges:** See Figure 9. Disconnect the oil pressure gauge [113] and lamp [112] connectors. Remove two hex nuts (D) and the back clamp (C), and remove the gauge (B) from the right lower opening in the inner fairing. Disconnect the air temperature gauge [115] and lamp [114] connectors and remove the gauge (A) in the same manner.
2. **ALL versions:** Disconnect the fuel gauge [117] and lamp [116] connectors. Remove two nuts and the back clamp, and remove the fuel gauge (A) from the left upper opening in the inner fairing.
3. Install the fuel gauge into the left lower opening. Slide the back clamp over the gauge studs. Verify that the tab on the back clamp engages the slot at the bottom of the inner fairing bore.
4. Loosely install the hex nuts on the studs. Verify that the gauge is properly aligned, then tighten the nuts to 1.2–2.2 N·m (10–20 **in-lbs**). Connect the fuel gauge [117] and lamp [116] connectors.
5. Disconnect the voltmeter gauge [111] and lamp [110] connectors, and reposition the voltmeter (B) to the right lower opening in the same manner.

Install Fairing Tweeters

1. See Figure 9. Get two tweeters (3) from the kit, and the two back clamps (C) and four hex nuts (D) from the gauges removed from the vehicle. **For vehicles that only had TWO auxiliary gauges**, two additional back clamps (Part No. 67352-96A) and four additional hex nuts (Part No. 67043-96) will be needed.
2. Install the tweeters into the left and right upper openings in the inner fairing. Slide the back clamp over the tweeter studs. Verify that the tab on the back clamp engages the slot at the bottom of the inner fairing bore.
3. Install the hex nuts on the studs, and tighten to 1.2–2.2 N·m (10–20 **in-lbs**).

Install Fairing Amplifier and Modules

NOTE

- If another module has been installed on top of the radio on the brake-lever side, relocate **that** module to the clutch-lever side of the radio per the instructions supplied with that module.

- If another module has been installed on top of the radio on the clutch-lever side, relocate **that** module per the instructions supplied with that module. An iPod module installed on top of the radio on the clutch-lever side can be relocated to the right-side saddlebag as described later in these instructions.

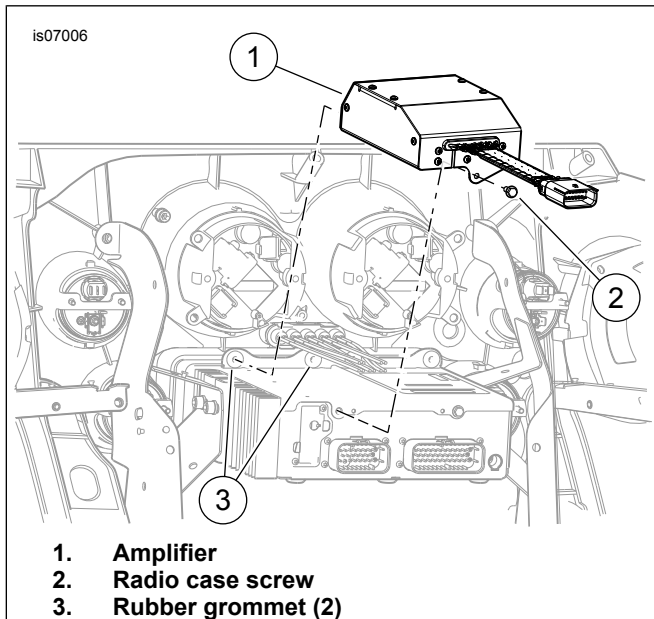

Figure 1. Front Amplifier Installation

1. See Figure 1. Remove the screw (2) at the back of the radio.
2. Position the amplifier (1) on top of the AM-FM radio case, with the metal cones on one end fitting firmly into the leftmost (brake-lever side) rubber grommets (3) at the front of the radio.
3. Fasten the amplifier to the radio with the radio case screw (2). Tighten to 4–5.1 N·m (35–45 in-lbs).

Harness Installation and Routing

NOTE

See Figure 2. Make note of the location of the black six-way Deutsch audio to interconnect harness connector [6] (Item 1) before moving the gray Molex 12-way connector [2] (Item 2).

1. Remove the gray Molex 12-way main to interconnect harness connector [2] from the left-side (clutch lever side) fairing bracket (radio support bracket, Item 3).

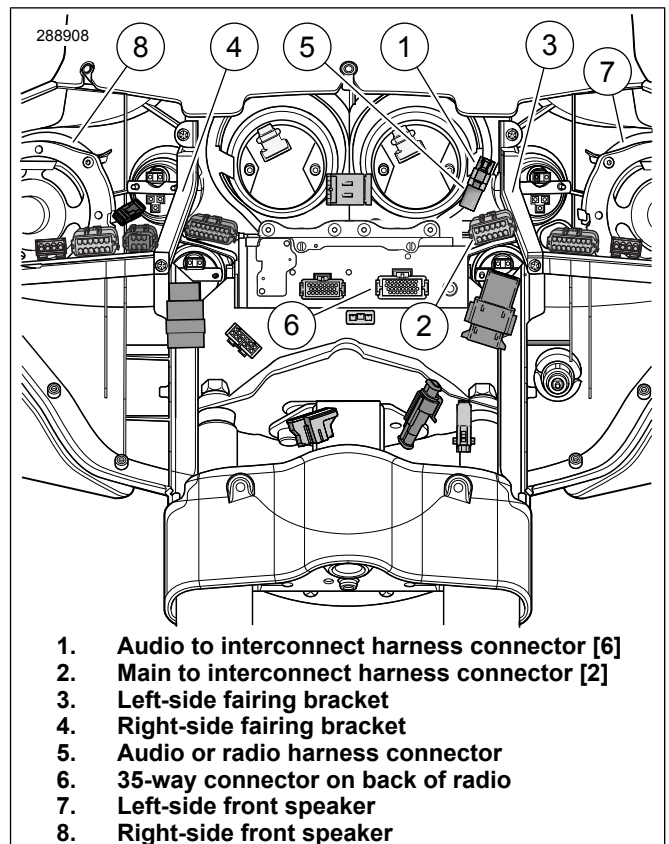

Figure 2. Inner Fairing Connectors (FLHX, FLHT/C/U)

2. See Figure 11. Get the audio harness (10) from the kit.
3. If there is currently a harness connected to the six-way vehicle interconnect harness socket housing [6B] and the 35-way receptacle [28A] on the back of the radio, disconnect and remove that harness from the vehicle. See Figure 3 and Table 1, Item 1. Plug the black six-way audio harness pin housing [6A] (labeled "CONNECTOR 6") from the **new** audio harness into the vehicle interconnect harness socket housing [6B].

NOTE

Six additional branches of the audio harness exit from the same end of the large conduit (see Figure 11):

- 45.7 cm (18 in) long, labeled "L. FAIRING SPKR (35F)", with two-way female Delphi connector [35FB] (Item 2) for left fairing speaker.
- 33 cm (13 in) long, labeled "L. TWEETER (35T)", with two-way female Delphi connector [35TB] (Item 4) for left tweeter.
- 40.6 cm (16 in) long, labeled "L. LWR (35L)", with two-way Amp socket housing [35LB] (Item 6) for left lower speaker.
- 10.2 cm (4 in) long, labeled "AMP (149)", with 16-way Molex socket housing [149B] (Item 8) for front amplifier.
- 22.9 cm (9 in) long, labeled "IPOD (274F)", with eight-way Deutsch socket housing [274F] (Item 13) for optional iPod module.
- 1.27 m (50 in) long, to rear of vehicle.

4. See Figure 3 and Table 1. Plug the two-way connector [35FB] (2) into the left fairing speaker. Plug the two-way connector [35TB] (4) into the left tweeter.
5. Plug the 16-way Molex socket housing [149B] (8) into the front amplifier.
6. At the opposite end of the large conduit, plug the 35-way Amp (Tyco) socket housing [28B] (Item 9) into the open receptacle on the back of the radio.

NOTE

The wires being removed from socket housing [27B] in the next step are from the former front speaker circuit, and are no longer live.

7. Unplug the **23-way** Amp socket housing [27B] (Item 10) from the back of the radio. Open the secondary lock per instructions in the service manual appendix. Remove the wires currently in cavities 1, 16, 17 and 18. Replace by inserting the four terminated wires (11) coming from the large conduit into the socket housing cavities as follows:
 - **Light green/black** wire into cavity 1.
 - **White/orange** wire into cavity 16.
 - **Light green/white** wire into cavity 17.
 - **Gray/red** wire into cavity 18.
8. Close the secondary lock per instructions in the service manual appendix, and plug the socket housing back into the receptacle on the back of the radio.

NOTE

Four additional branches of the audio harness exit from the same end of the large conduit (see Figure 11):

- *45.7 cm (18 in) long, labeled "R. FAIRING SPKR (34F)", with two-way female Delphi connector [34FB] (Item 3) for right fairing speaker.*
 - *33 cm (13 in) long, labeled "R. TWEETER (34T)", with two-way female Delphi connector [34TB] (Item 5) for right tweeter.*
 - *40.6 cm (16 in) long, labeled "R. LWR (34L)", with two-way Amp socket housing [34LB] (Item 7) for right lower speaker.*
 - *20.3 cm (8 in) long, labeled "XM (185X)", with twelve-way Deutsch socket housing [185X] (Item 12) for optional XM satellite radio module.*
9. Plug the two-way connector [34FB] (3) into the right fairing speaker. Plug the two-way connector [34TB] (5) into the right tweeter.

10. If equipped, plug the twelve-way Deutsch socket housing [185X] (Item 12) into the XM satellite radio module.

NOTE

*The optional iPod module can be mounted either **in the front fairing or right-side saddlebag.***

11. **If an iPod module is mounted in the front fairing**, plug the eight-way Deutsch socket housing [274F] (Item 13) into the iPod module.
12. Route the left lower speaker branch of the audio harness (6, with white/orange and light green/white wires) down along the left side of the steering head to the left center of the engine guard. Route the right lower branch (7, with gray/red and light green/black wires) down along the right side of the steering head to the right center of the engine guard.

NOTE

Position connectors [34LB] and [35LB] outside the upper fairing to allow easy disconnection when removing fairing lowers.

13. Use cable straps from the kit to fasten the upper section of the audio harness to nearby wiring inside the fairing.
14. Route the long branch of the audio harness along the clutch-lever side of the radio and rearward, through the openings in the wire caddy alongside other harnesses down the vehicle backbone. Use cable straps to fasten to other harnesses in the caddy.

▲ WARNING

Be sure that steering is smooth and free without interference. Interference with steering could result in loss of vehicle control and death or serious injury. (00371a)

- Be sure wires do not pull tight when handlebars are turned fully to left or right fork stops.
15. Route the harness along the right side of the battery cavity. Bring the red fuse holder [43] (Item 14), black ground wire (15) and black/green ground wire (16) into the front of the battery compartment. Position the fuse holder in an easily accessible location. Position the four-way P&A socket housing [4B] (Item 17) and B+ connector (18) in the area under the seat.
 16. Mate socket housing [4B] to pin housing [4A] on the vehicle. Mate the B+ connector to connector [160B] on the vehicle.
 17. Fasten the black ground wire ring terminal to the left ground stud [GND 1]. Fasten the black/green ground wire ring terminal to the right ground stud [GND 2].
 18. Route the two long branches rearward to the front of the rear fender. Use a cable strap to fasten both branches to the frame.

is07163a

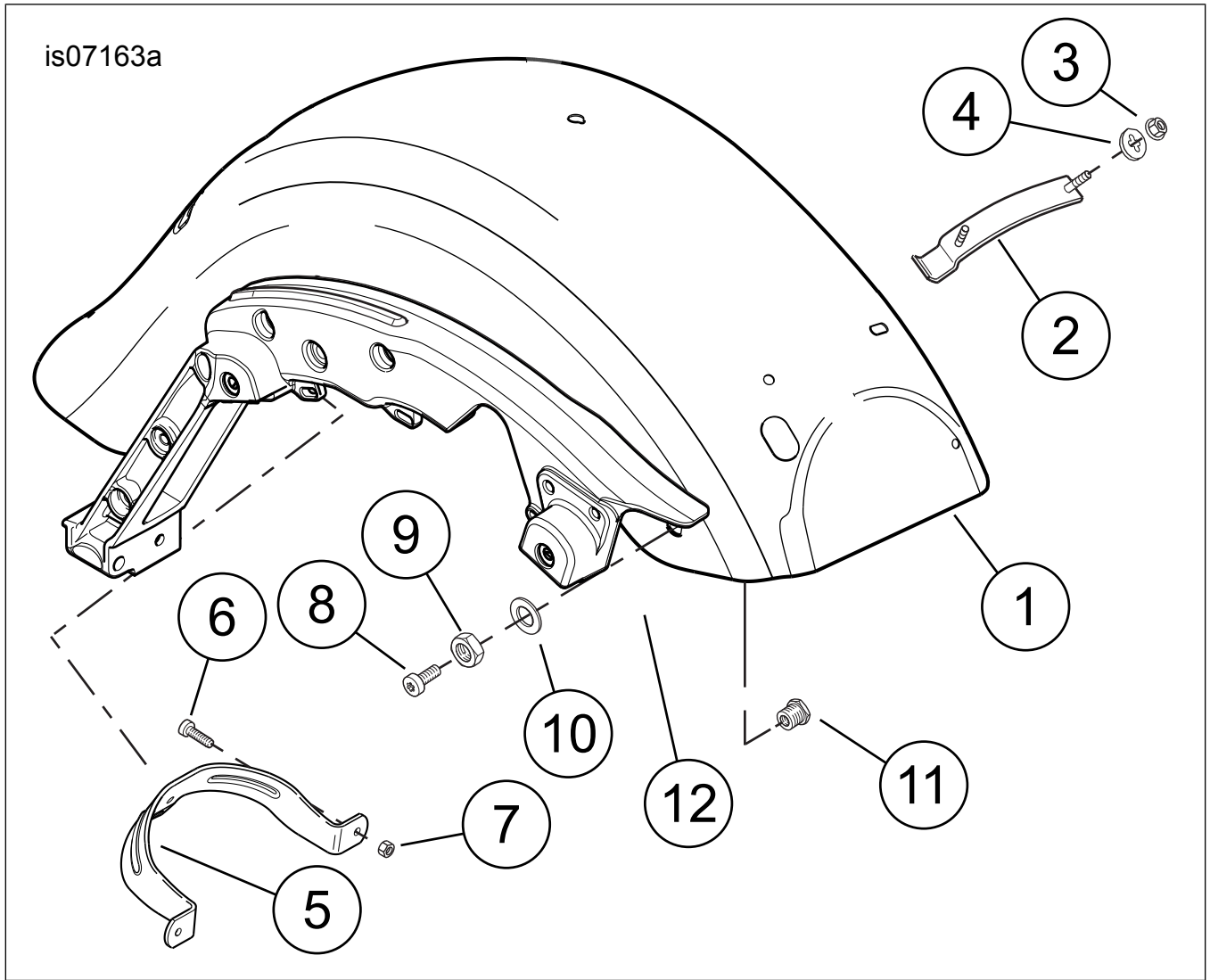

Figure 3. Wiring Diagram, Audio Harness 69200321

Table 1. Wiring Diagram, Audio Harness 69200321

Item	Description
1.	Six-way pin housing [6A] to interconnect harness (labeled "CONNECTOR 6")
2.	Two-way female Delphi connector [35FB] to left fairing speaker, labeled "L. FAIRING SPKR (35F)"
3.	Two-way female Delphi connector [34FB] to right fairing speaker, labeled "R. FAIRING SPKR (34F)"
4.	Two-way female Delphi connector [35TB] to left tweeter, labeled "L. TWEETER (35T)"
5.	Two-way female Delphi connector [34TB] to right tweeter, labeled "R. TWEETER (34T)"
6.	Two-way Amp socket housing [35LB] for left lower speaker, labeled "L. LWR (35L)"
7.	Two-way Amp socket housing [34LB] for right lower speaker, labeled "R. LWR (34L)"
8.	16-way Molex socket housing [149B] for front amplifier, labeled "AMP (149)"
9.	35-way socket housing [28B] to back of radio
10.	23-way Amp socket housing [27B] to back of radio
11.	Four terminated wires from large conduit
12.	Twelve-pin Deutsch socket housing [185X] for XM satellite radio module, labeled "XM (185X)"
13.	Eight-way Deutsch socket housing [274F] for iPod module, labeled "IPOD (274F)"
14.	Red amplifier fuse wire [43B]
15.	Black ground ring terminal
16.	Black/green ground ring terminal
17.	Four-way P&A accessory connector [4B], labeled "ACCY CONNECTOR 4"
18.	B+ connector, labeled "B+ (160)"
19.	Left saddlebag connector [288B], labeled "LH S'BAG (288)"
20.	Right saddlebag connector [289B], labeled "RH S'BAG (289)"

Modify and Install Vented Fairing Lower

- See Figure 10. Disassemble the vented fairing lowers per service manual instructions with the following exceptions:
 - Remove the glove box, door and tether (F) from the lower fairing (E) per the disassembly instructions in the service manual. Keep the screws (J).
 - Remove the vent door (H) from the glove box, making note of the order and orientation of the attaching parts.
 - Install the vent door onto the **new** speaker housing (4) from **this** kit with the attaching parts in the same order and orientation as just removed. Tighten the locknut (I) per service manual instructions.
- Secure the speaker housing to the lower fairing with the three screws (J) removed in Step 1a. Tighten the screws to 2.3–2.8 N·m (20–25 in-lbs).
- See Figure 4. In the upper part of the fairing (1), measure about 25 mm (1.0 in) over (2) and 12 mm (0.5 in) up (3) from the lower fairing cap mating flange (shaded area), and drill a 9.5 mm (3/8 in) hole (4) in the glove box inboard side wall and speaker housing. See Figure 10. Install a grommet (8) into the hole in the glove box wall.
- From the inside, route the terminated wires of a fairing lower speaker harness (6) through the large opening in the face of the speaker housing, and through the grommet in the glove box wall.

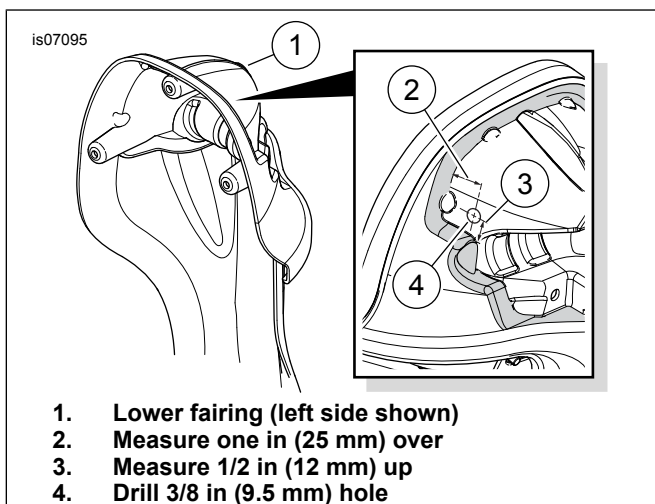

Figure 4. Drill Speaker Wire Hole in Lower Fairing

- Get a two-way pin housing (7) from the kit. Insert the red/orange wire and terminal into cavity 1 of the pin housing per instructions in the service manual appendix. Insert the light green wire and terminal into cavity 2.
- Plug the pin housing into the mating socket housing of the audio harness.
- Place the lower fairing per service manual instructions, using a **new** rubber washer (K, Part No. 7415A) at the bottom attachment point to the engine guard.

- Plug the socket housing into the back of the speaker.
- Position the fairing cap (G) against the lower fairing, align and install the lower fairing per service manual instructions.
- Repeat on the opposite side of the vehicle.

SADDLEBAG PREPARATION

Saddlebag Lid Removal

NOTE

- Remove all items from the saddlebags.
- The saddlebags do not have to be removed from the vehicle to perform the **lid removal** procedure.
- Take care to avoid damage to the saddlebag bottom when removing the lid.

- Remove two screws to release the check strap from the **saddlebag lid only**.
- Remove five screws to release the lid from the saddlebag latch. The latch can remain attached to the saddlebag bottom. Retain the screws and backing plate for installation of the **new** saddlebag lid. The removed lid can be discarded or set aside.
- Repeat for the remaining saddlebag lid.

Saddlebag Drilling

- Lay a clean pad or blanket on the work surface to protect the painted surfaces of the saddlebag.
- Remove one saddlebag bottom from the vehicle per service manual instructions. Lay it, outboard side down, on the protected work surface.

NOTE

If used with Twin Rail Chrome Saddlebag Guard Kit (Part No. 90862-09 or 91216-97), use the available drill template (Part No. 76000265, purchased separately) instead of following the instructions below.

- See Figure 5. Lay a strip or strips of masking tape in the approximate area of the holes to be made in the inboard saddlebag wall for the saddlebag jumper harness connector. Very carefully measure and mark the hole locations as shown.
- Mark the centers of the two holes with a center punch. Drill two 7 mm (9/32 in) diameter holes in the saddlebag wall.
- Carefully cut the rectangular hole for the connector body.
- Remove the tape. Lightly sand the hole to remove burrs and sharp edges. Clean the saddlebag wall surface of tape residue with a mixture of 50-70% isopropyl alcohol and 30-50% distilled water. Allow to dry thoroughly.
- Set the saddlebag aside, and repeat Steps 1-6 for the opposite side saddlebag.

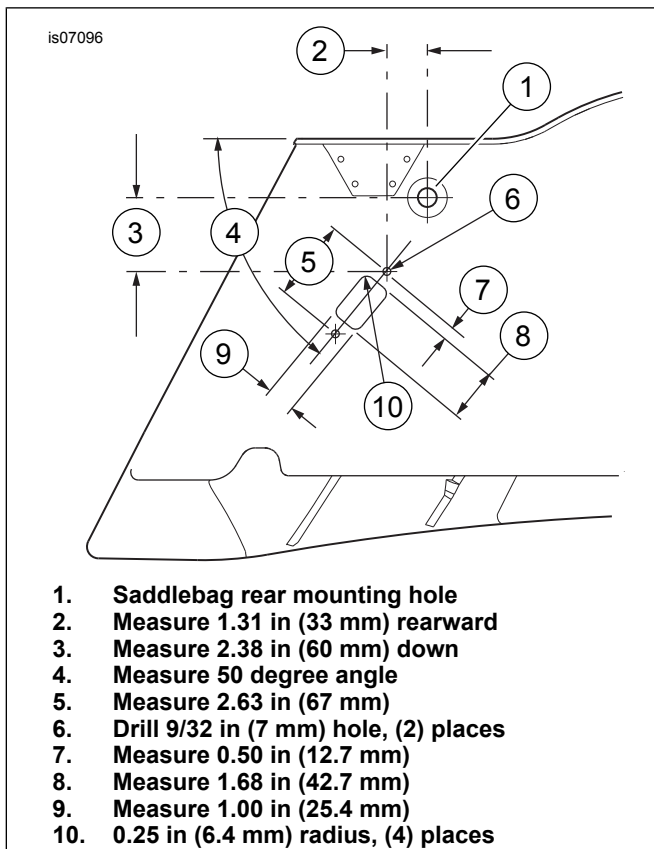

Figure 5. Cut Connector Holes in Inboard Saddlebag Wall (Left Bag Shown)

Saddlebag Lid Assembly

NOTE

Unfinished saddlebag lids must be finish painted before installation.

1. See Figure 12 and Table 4. Get the gasket (N), mounting plate (O), two wear plates (M) and the finish painted saddlebag lid (L) from one of the saddlebag lid kits (purchased separately).

NOTE

Ambient temperature should be **at least** 16 °C (60 °F) for proper adhesion of the wear plates and gasket to the saddlebag lid.

2. See Figure 6. Remove the liner from the adhesive backing of one of the wear plates (2). Carefully position the wear plate to the saddlebag lid (1), centering it on the tab (3), and press firmly into place. Hold the wear plate in position with steady pressure for about a minute. Repeat with the second wear plate at the other end of the lid.

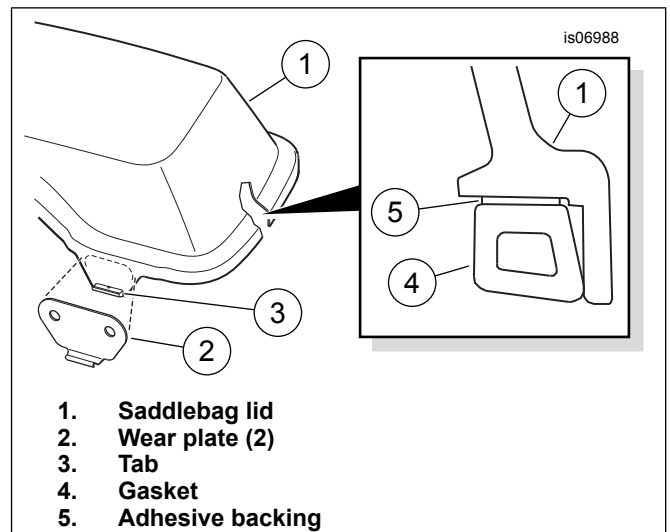

Figure 6. Assemble Wear Plates and Gasket to Saddlebag Lid

3. See Figure 12. Lay the mounting bracket (O) onto the lid flange, lining up the five mounting holes.

NOTE

- Orient the gasket with the **tall edge** toward the outer lip of the cover as shown in Figure 6.
 - Begin gasket installation in the center of the inboard side of the lid, opposite the hinge (see Figure 8, Item 15).
 - Gasket adhesive will hold the mounting plate in place.
4. Gradually remove the liner from the adhesive backing (Figure 6, Item 5) of the saddlebag lid gasket (4) as the gasket is pressed into place around the inside perimeter of the lid (1) as shown.
 5. Set the lid, gasket side down, on the clean pad or blanket of the work surface.
 6. See Figure 12. Get a saddlebag speaker assembly (18), speaker basket (12) and four #8-18 x 31.8 mm (1.25 in) long screws (19) from the speaker kit.
 7. From the underside of the saddlebag lid, and with the large rectangular opening (Q) toward the front, place the speaker basket under the speaker cavity and snap it into the lid.
 8. Insert a screw, from the top, through each mounting hole in the speaker. With the tweeter (P) toward the front of the saddlebag, install the speaker into the cavity at the front of the saddlebag lid.
 9. Align the four screws with the mounting holes in the basket, and tighten to 25.4–38.1 N·m (10–15 in-lbs).
 10. Get the correct speaker grille (13 or 14), four rubber washers (20) and four #8-18 x 19 mm (0.75 in) long screws (21) from the speaker kit.
 11. Place a rubber washer into the well surrounding each grille mounting hole in the lid.

12. Place the speaker grille into position over the speaker face. From the underside of the saddlebag lid, insert the screws through the holes in the lid and into the mounting pads in the grille. Tighten the screws to 25.4–38.1 N·m (10–15 in-lbs).
13. Repeat Steps 1 through 12 for the opposite-side saddlebag lid.
14. Fasten the **new** lid to the saddlebag latch and bottom with the five screws (R) removed earlier. Tighten to 2.3–2.8 N·m (20–25 in-lbs).

NOTE

See Figure 7. The saddlebag latch hinge is shown with the pins removed for clarity.

15. Get two foam pads (Figure 12, Item 24) from the kit. Cut one piece in half as shown in Figure 7. Remove the liner from the adhesive backing of the **uncut** pad and affix to the flat side of the latch connector segment. Remove the liner from the adhesive backing of one cut pad and affix to the hinge side of the latch connector segment as shown.

NOTE

The remaining foam pad segment can be cut and used as needed to eliminate any saddlebag vibration induced by speaker operation.

16. Assemble the remaining saddlebag in the same manner.

SADDLEBAG HARNESS INSTALLATION

Left Saddlebag Harness

1. See Figure 12. Get the left-side saddlebag, the correct saddlebag speaker jumper harness (15), a plug cover (25) and two screws (26) from the kit.
2. Feed the jumper harness connectors [149R] and [42S], from the outside, through the rectangular opening cut in the saddlebag inboard wall so the 12-way panel mount connector [288] (Item T) fits into the opening.

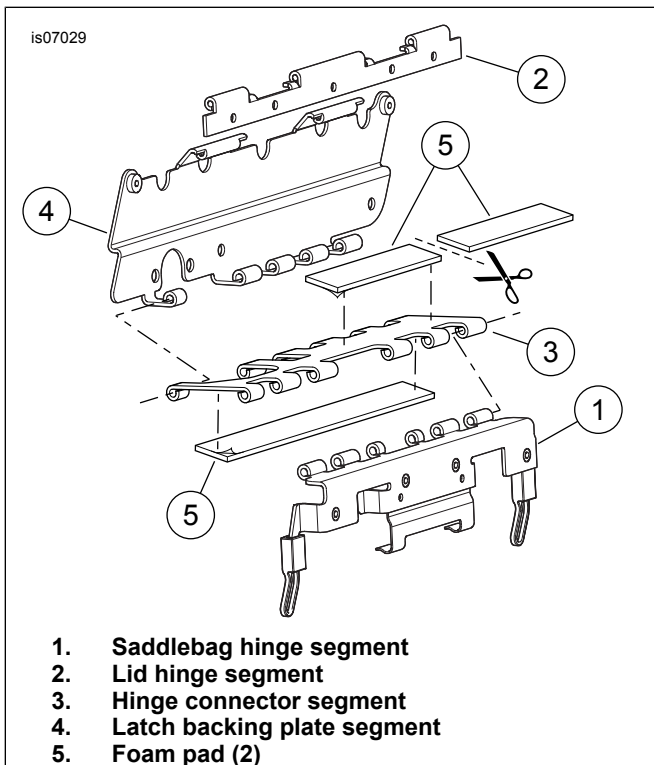
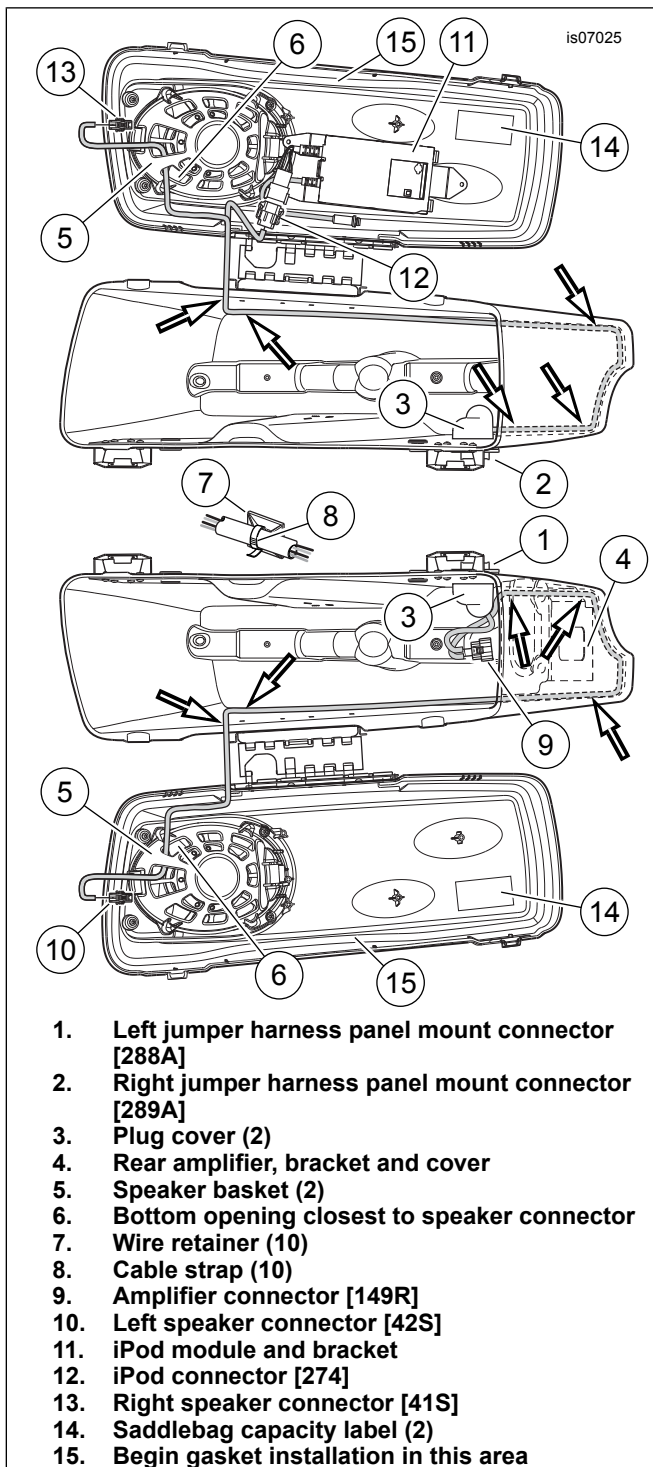

Figure 7. Install Foam Pads to Saddlebag Latch Hinge (Left Side Shown)



1. Left jumper harness panel mount connector [288A]
2. Right jumper harness panel mount connector [289A]
3. Plug cover (2)
4. Rear amplifier, bracket and cover
5. Speaker basket (2)
6. Bottom opening closest to speaker connector
7. Wire retainer (10)
8. Cable strap (10)
9. Amplifier connector [149R]
10. Left speaker connector [42S]
11. iPod module and bracket
12. iPod connector [274]
13. Right speaker connector [41S]
14. Saddlebag capacity label (2)
15. Begin gasket installation in this area

Figure 8. Harness Routing Inside Saddlebags

3. See Figure 8. Install the plug cover (3) over the panel mount connector (1) and jumper harness from the **inside** of the saddlebag. Insert two screws through the connector flange and saddlebag wall, and into the threaded holes in the plug cover. Tighten to 3.95–4.52 N·m (35–40 **in-lbs**)
4. Route the harness:
 - a. downward to the bottom of the saddlebag, and
 - b. rearward along the inboard wall.

- c. Route the long leg of the harness, with connector [42S], across the rear of the saddlebag,
- d. forward along the outboard wall, and
- e. upward in front of the saddlebag lid tether.

5. Route connector [42S] through the bottom opening (6) of the speaker basket (5) closest to the speaker connector, and plug into the speaker connector.
6. Get five wire retainers (7) and five cable straps (8) from the kit. Remove the liner from the adhesive backing of each wire retainer and affix to the inside walls of the saddlebag, about 25 mm (1 in) above the bottom of the saddlebag as shown. Fasten the jumper harness to the wire retainers with the cable straps.
7. See Figure 12. Get the rear amplifier (29), bracket (27), T-stud anchor (28), screw (30), cover (31) and three push-in clips (32) from the kit.
8. Remove the liners from the adhesive backing of the amplifier bracket. Carefully position the bracket to the rear inboard corner of the saddlebag in the orientation shown, and press firmly into place. Hold the bracket in position with steady pressure for a few minutes.
9. Position the amplifier onto the bracket, with the metal cones on one end fitting firmly into the rubber grommets in the bracket.
10. Fasten the amplifier to the bracket with the screw (30).
11. Attach the T-stud connector to the amplifier connector.
12. Plug saddlebag speaker jumper harness connector [149R] into the amplifier connector. Attach the anchor to the T-stud on the amplifier bracket.
13. Place the foam cover over the amplifier, and install the cover to the amplifier bracket with the three push-in screws.

Right Saddlebag Harness

1. Install the remaining saddlebag speaker jumper harness (Figure 12, Item 16) in the right-side saddlebag in the same manner, with the following exception:
 - See Figure 8. Route **both** legs of the harness downward, then rearward around to the outboard wall and upward in front of the saddlebag lid tether to the saddlebag lid.
2. Route connector [41S] (Item 13) through the bottom opening (6) of the speaker basket (5) closest to the speaker connector, and plug into the speaker connector .
3. Affix five wire retainers (7) to the inside walls of the saddlebag, about 25 mm (1 in) above the bottom of the saddlebag as shown. Fasten the jumper harness to the wire retainers with cable straps (8).
4. See Figure 12. If the iPod module (U) is being mounted to the saddlebag lid, follow the instructions in the iPod module mounting kit.
5. Install the saddlebags to the vehicle per service manual instructions.

6. See Figure 3 and Table 1. Plug the audio harness connector [288B] into the left-side saddlebag harness connector. Plug the audio harness connector [289B] into the right-side saddlebag harness connector.
7. Fasten the saddlebag legs of the audio harness to the upper rear of the saddlebag supports so there is just enough harness loose to comfortably reach the saddlebags.

AUDIO SOFTWARE UPGRADE

The purchase of this kit entitles you to a specially developed sound equalization software that is used in conjunction with the Advanced Audio system. This unique equalization was designed to optimize the performance and sound response of the Custom Touring Audio System.

Even if this kit is not being installed by a Harley-Davidson dealer, this special equalization **software** is available without charge from your dealer through Digital Technician II. Dealer labor rates may apply for the upgrade procedure.

RETURN TO SERVICE

1. Have a Harley-Davidson dealer apply the specially developed sound equalization **software** to the vehicle to optimize the performance and sound response of the Custom Touring Audio System.

NOTE

To prevent possible damage to the sound system, verify that the ignition switch is in the OFF position before installing the main fuse.

2. Verify that the ignition switch is in the OFF position.
3. Refer to the service manual and follow the instructions to install the main fuse.
4. Test the radio and speaker controls for proper operation.
5. Install the outer fairing and windshield. Refer to the service manual.

▲ WARNING

After installing seat, pull upward on seat to be sure it is locked in position. While riding, a loose seat can shift causing loss of control, which could result in death or serious injury. (00070b)

6. Refer to the service manual and follow the instructions to install the seat.

IN USE

A small amount of water may at times collect in the saddlebag speaker cavities while parked outdoors. The saddlebag speakers are weatherproof, and the heat from speaker operation would soon evaporate the water, but there could be a temporary effect on sound quality. To promptly empty the speaker cavities, lift the saddlebag lids.

Weather caps (see Figure 12, Item 33) are provided to protect the lower fairing and saddlebag connectors **on the vehicle** when those items are removed for cleaning or servicing.

SERVICE PARTS

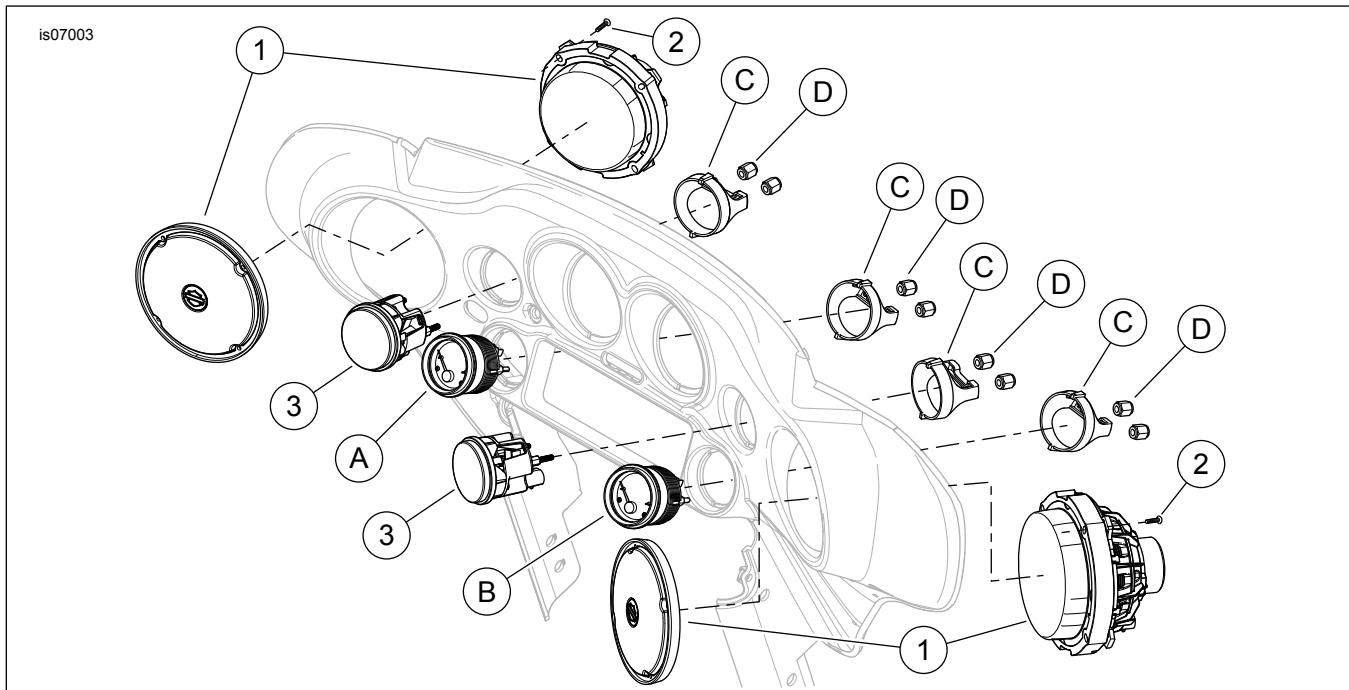

Figure 9. Service Parts, Custom Touring Audio System; Upper Fairing Speakers (See Table 2)

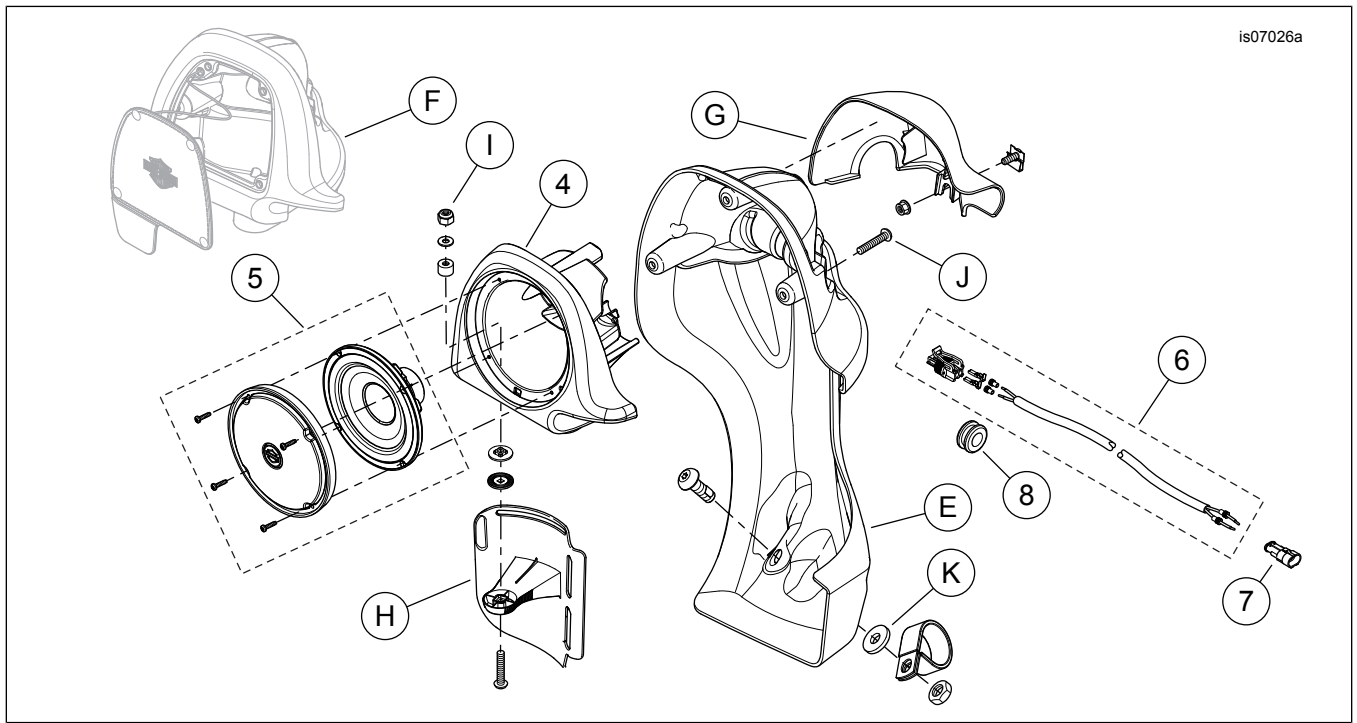

Figure 10. Service Parts, Custom Touring Audio System; Lower Fairing Speakers (See Table 2)

SERVICE PARTS

Table 2. Service Parts, Custom Touring Audio System; Lower Fairing and Front Speakers (See Figures 9-10)

Item	Description (Quantity)	Part Number
1	Speaker, 133 mm (5.25 in) diameter (right side) Speaker, 133 mm (5.25 in) diameter (left side)	77033-11A 77042-11A
2	Screw, hex slotted washer head, Hi-Lo, #10-12 x 38 mm (1.5 in) long (6)	10200013
3	Speaker (tweeter), 25.4 mm (1.0 in) diameter (2)	77036-11A
4	Housing, lower fairing speaker (right side, unpainted) Housing, lower fairing speaker (left side, unpainted)	Not sold separately Not sold separately
5	Speaker, lower fairing, 165 mm (6.5 in) diameter (2)	76000201
6	Wire harness, lower fairing speaker (2)	72676-11
7	Pin housing, two-way, AMP Superseal (2)	72009-05
8	Grommet (2)	11410
Items mentioned in text, but not included in kit:		
A	Fuel gauge	
B	Voltmeter	
C	Back clamp, 50.8 mm (2 in) diameter gauge (4)	
D	Nut, back clamp (8)	
E	Lower fairing	
F	Glove box, door and tether	
G	Lower fairing cap	
H	Vent	
I	Lock nut (2)	
J	Screw, glove box door (6)	
K	Rubber washer, Part No. 7415A (2)	

SERVICE PARTS

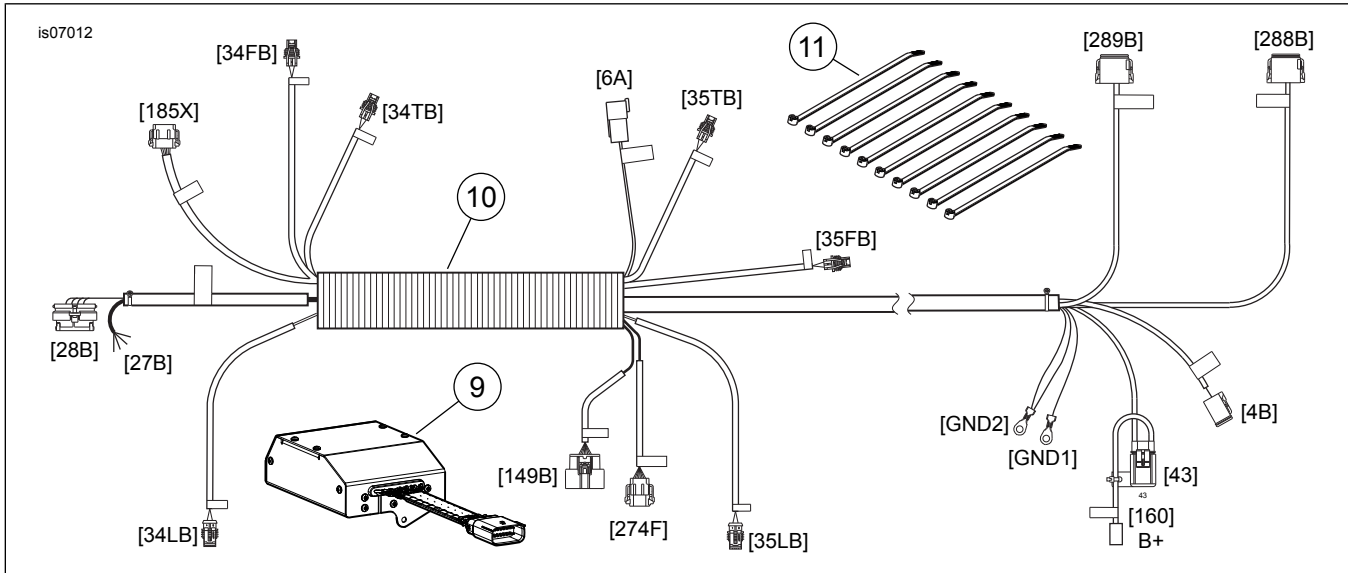

Figure 11. Service Parts, Custom Touring Audio System; Front Amplifier and Audio Harness (See Table 3)

Table 3. Service Parts, Custom Touring Audio System; Front Amplifier and Audio Harness (See Figure 11)

Item	Description (Quantity)	Part Number
9	Amplifier, front speaker (fairing mounted)	76000141
10	Audio harness	Not sold separately
11	Cable strap (10)	10006

Table 4. Service Parts, Touring Model Saddlebag Lids With Speaker Mount (See Figure 12)

Item	Description (Quantity)	Kit or Part Number
	Saddlebag Lid Kit; Available separately. Not part of Custom Touring Audio System Kit 76000209	
	• Left (Unfinished)	90200612
	• Right (Unfinished)	90200613
	• Left (Vivid Black)	90200614
	• Right (Vivid Black)	90200615
L	Lid (cover), saddlebag	Not sold separately
M	Wear plate (2)	90962-93
N	Gasket, cover	90675-93A
O	Mounting bracket	12700035

SERVICE PARTS

Table 5. Service Parts, Custom Touring Audio System; Saddlebag Components (See Figure 12)

Item	Description (Quantity)	Part Number
12	Basket, speaker protective (2)	76000182
13	Grille, speaker (left)	Not sold separately
14	Grille, speaker (right)	Not sold separately
15	Harness, saddlebag speaker jumper (left)	69200159
16	Harness, saddlebag speaker jumper (right)	69200160
17	Saddlebag capacity label (2)	14000069
18	Speaker assembly, 5x7 (2)	76000142
19	Screw, Hi-Lo, #8-18 x 31.8 mm (1.25 in) long (8)	10200095
20	Rubber washer (8)	25700117
21	Screw, Hi-Lo, #8-18 x 19 mm (0.75 in) long (8)	10200012
22	Wire retainer, adhesive back (10)	69200342
23	Cable strap (10)	10065
24	Pad, saddlebag latch (4)	Not sold separately
25	Plug cover (2)	69200329
26	Screw, TORX button head, 1/4-20 x 19 mm (0.75 in) long (4)	940

Table 5. Service Parts, Custom Touring Audio System; Saddlebag Components (See Figure 12)

Item	Description (Quantity)	Part Number
27	Amplifier bracket	Not sold separately
28	T-stud anchor	73212-07
29	Amplifier	76000141
30	Screw, TORX, #10-24 x 12.7 mm (0.50 in) long	3658
31	Cover, amplifier	76000140
32	Clip, push-in (3)	12600068
33	Weather cap kit	Not sold separately
Items mentioned in text, but not included in kit:		
P	Tweeter (2), part of rear speaker assemblies	
Q	Large opening in speaker protective basket	
R	Saddlebag lid to bottom attaching screw (10)	
S	Panel mount connector hole in saddlebag side wall (2)	
T	12-way panel mount connector (2)	
U	iPod module (Part No. 72647-11)	
V	Bracket, iPod module mounting (Part No. 69200244)	
W	Screw, TORX, #10-24 x 12.7 mm (0.50 in) long (Part No. 3658)	
X	Screw, TORX, pan head, self-tapping, #10-24 x 12.7 mm (0.50 in) long (3) (Part No. 3612)	
Y	iPod docking harness (Part No. 69200157)	

SERVICE PARTS

is07071a

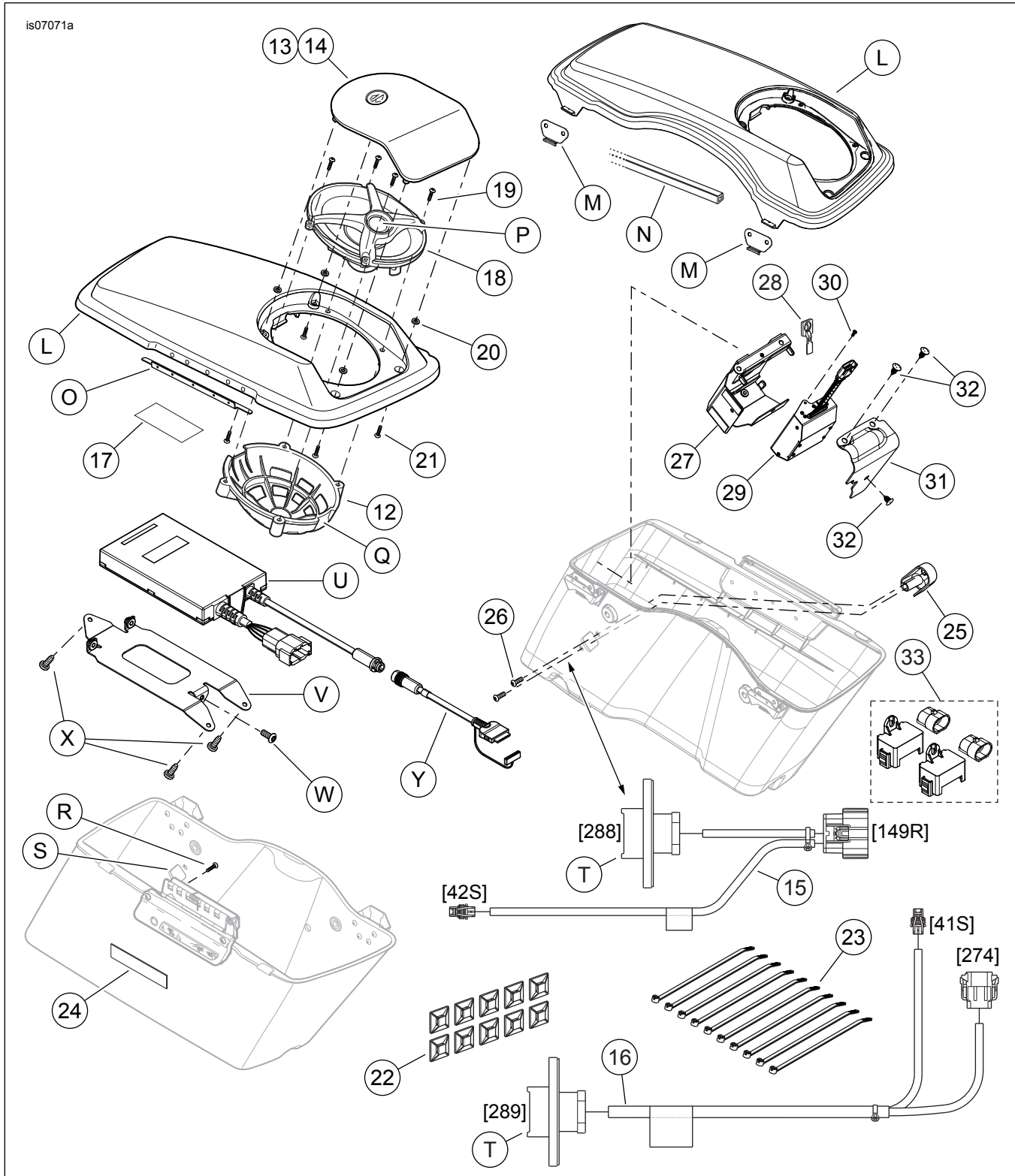

Figure 12. Service Parts, Custom Touring Audio System; Saddlebag Components (See Tables 4-5)