



INSTRUCTIONS

J05213

2010-07-19



DELUXE AUXILIARY LAMP KIT

GENERAL

Kit Number

68669-05A, 68670-05A

Models

For model fitment information, see the P&A Retail Catalog or the Parts and Accessories section of www.harley-davidson.com (English only).

Additional Parts Required

2011 Softail will require use of an UltraTorch UT-100 (Part No. HD-39969), Robinair Heat Gun (Part No. HD-25070) with Heatshrink Attachment (Part No. HD-41183), or other suitable radiant heating device.

Crimping tool (HD-38125-8)

⚠ WARNING

Rider and passenger safety depend upon the correct installation of this kit. Use the appropriate service manual procedures. If the procedure is not within your capabilities or you do not have the correct tools, have a Harley-Davidson dealer perform the installation. Improper installation of this kit could result in death or serious injury. (00333b)

NOTE

This instruction sheet references service manual information. A service manual for your model motorcycle is required for this installation and is available from a Harley-Davidson Dealer.

Kit Contents

See Figure 12 and Table 2.

INSTALLATION

Preparing the Motorcycle

⚠ WARNING

To prevent spray of fuel, purge system of high-pressure fuel before supply line is disconnected. Gasoline is extremely flammable and highly explosive, which could result in death or serious injury. (00275a)

⚠ WARNING

Gasoline can drain from quick-connect fitting when removing fuel line. Gasoline is extremely flammable and highly explosive, which could result in death or serious injury. Wipe up spilled fuel immediately and dispose of rags in a suitable manner. (00267a)

1. **For FLSTFI (EFI) models:** Purge the fuel supply line of high pressure gasoline and remove the fuel supply line.
 - a. Remove the fuel pump fuse from the fuse box under the seat.
 - b. Start the engine and allow the engine to run.
 - c. When the engine stalls, operate the starter for 3 seconds to remove any remaining fuel from the fuel lines.
 - d. To disconnect, pull up on the sleeve of the quick connect fitting and pull down on the fuel supply line.
2. Following the instructions in the owner's manual, remove the seat.

⚠ WARNING

To prevent accidental vehicle start-up, which could cause death or serious injury, disconnect negative (-) battery cable before proceeding. (00048a)

3. Disconnect the negative battery cable.

⚠ WARNING

Gasoline can drain from the carburetor fuel line when disconnected from fuel valve fitting. Gasoline is extremely flammable and highly explosive, which could result in death or serious injury. Wipe up spilled fuel immediately and dispose of rags in a suitable manner. (00256a)

4. **For FLSTF (carbureted):** Turn the fuel supply valve to OFF. Remove the fuel line from the fuel supply valve and drain fuel into approved gasoline container.



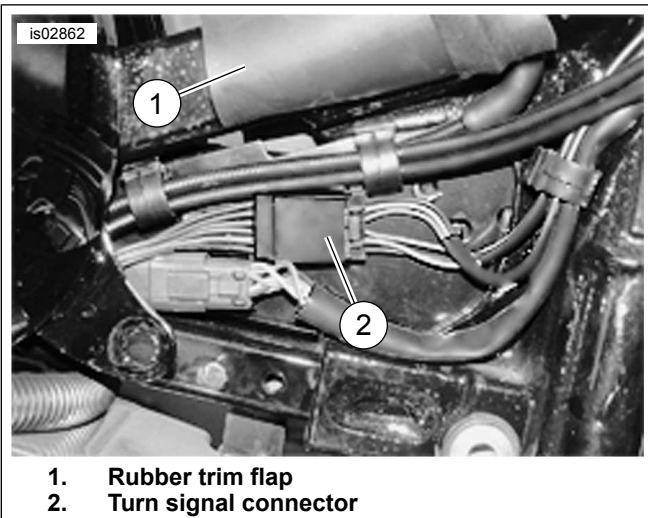

1. Rubber trim flap
2. Turn signal connector

Figure 1. Turn Signal Connector [31] (frame backbone right side)

5. Remove the acorn nut and washer from the console on top of the fuel tank. Gently set the console on the tank.
6. Pull the vent line off the fuel tank.
7. Separate fuel sender connector [86] from the top plate.
8. Remove TORX[®] bolt and washer at rear of fuel tank.
9. Remove acorn nut, washer and front mounting bolt from the front of the fuel tank at the steering head.
10. Gently pull tank back to access main harness connectors under rubber trim on sides of the frame backbone.

NOTE

Before separating connectors, removing wire bundles from frame clips or cutting any cable wraps, note the locations of all clips and cable wraps.

INSTALLATION

2011 And Later Softail FLSTF

1. See Figure 2. Cut the turn signal wires and conduit flush with the grommet (1) on the underside of the handlebar lower switch housing (2). Remove and discard stock turn signals.

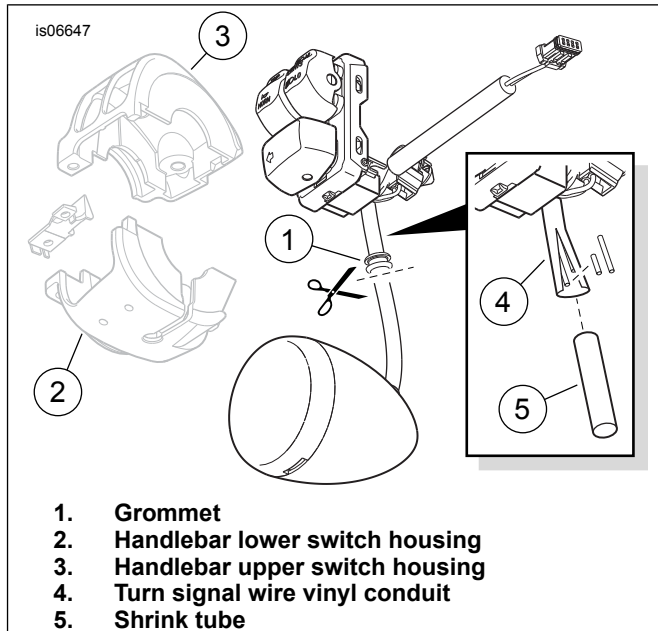

1. Grommet
2. Handlebar lower switch housing
3. Handlebar upper switch housing
4. Turn signal wire vinyl conduit
5. Shrink tube

Figure 2. Cut Turn Signal From Switch Assembly

2. Separate the upper (3) and lower switch housings per service manual instructions.
3. Remove the grommet from the end of the turn signal wire vinyl conduit (4) still connected to the switch housing.
4. Make about a one inch (25 mm) long slit in the end of the conduit. Cut one wire back about 1/2 inch (12 mm) from the end of the conduit. Cut the second wire back about 1/4 inch (6 mm) from the end of the conduit.
5. Slip the two-inch (50.8 mm) long section of encapsulating (dual wall) shrink tube (5) over the conduit and wires.
6. Use a heat gun or suitable radiant-heating device to shrink the tubing to the wires and conduit.
7. Assemble the switches and switch housings to the handlebar per service manual instructions, tucking the shrink-sealed wire ends back inside the switch housings. Repeat on the opposite side of the vehicle.
8. See Figure 3. Install the mirrors using lockwashers and spacers on the mirror shaft and secure with an acorn nuts from the kit. If the acorn nut bottoms out without tightening, remove the acorn nut, add a spacer from the kit and install acorn nut and tighten.

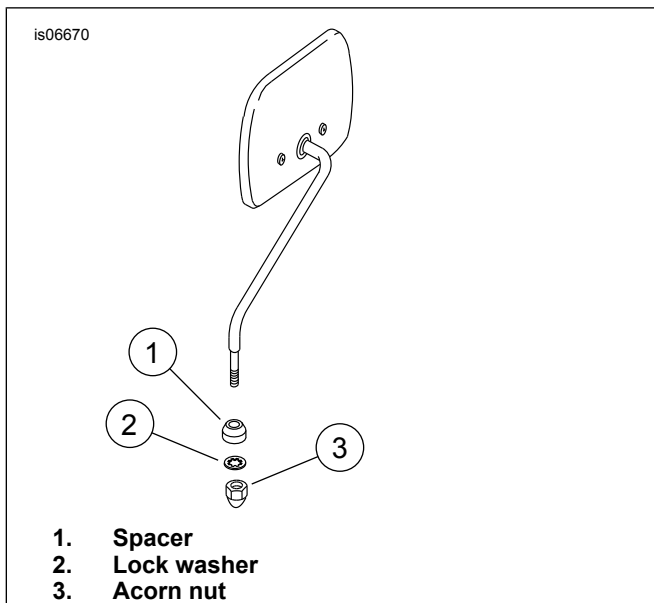

Figure 3. Mirror Hardware

Remove Headlamp and Trim Panels

1. See Figure 4. On the right side, lift up the rubber trim flap (1), separate the turn signal connector [31] (2) and pull the wire bundles from the frame clip.
2. See Figure 5. On the left side, lift up the rubber trim flap (1), separate the headlamp connector [38] (2) and pull the wire bundle from the frame clip.
3. Unbolt and remove head lamp shell pulling wire bundles through the front fork.

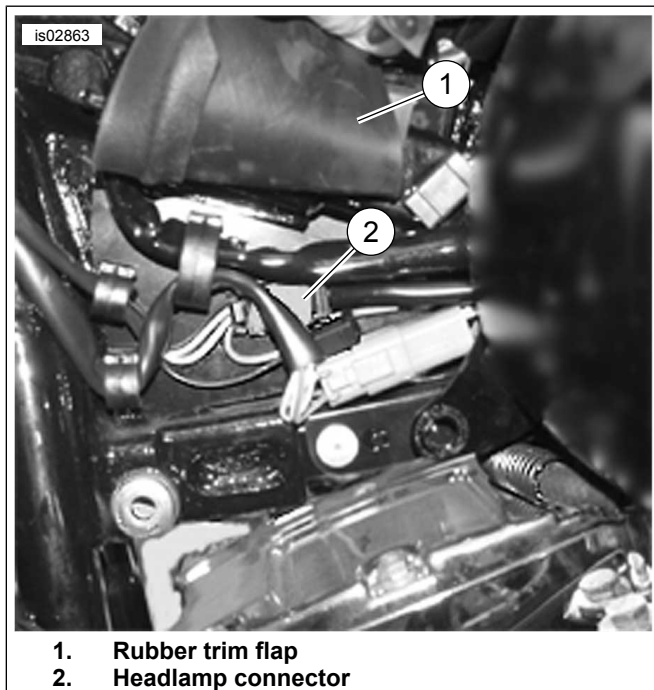

Figure 4. Headlamp Connector [38] (frame backbone, left side)

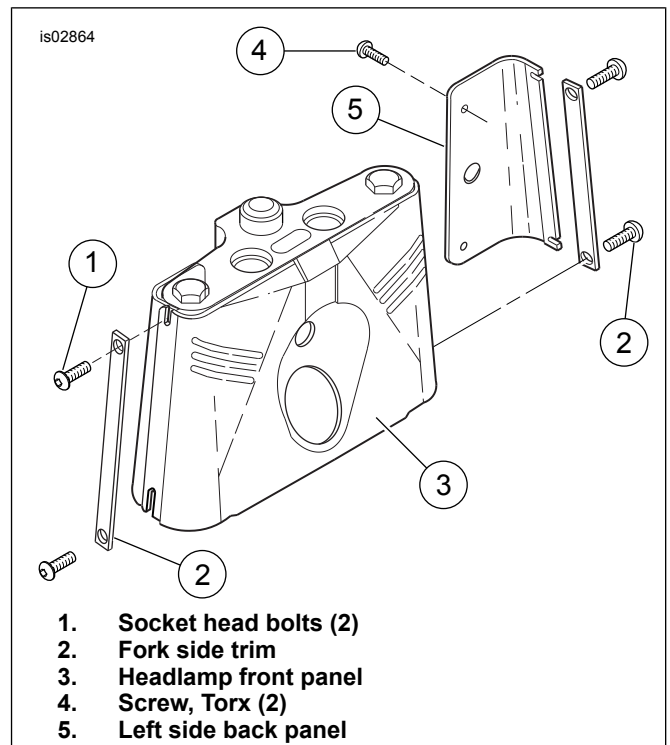

Figure 5. Fork Panels

4. See Figure 5. Remove and discard two socket head bolts (1) from each side of the fork side trim (2).
5. Remove and discard the side trim and remove and discard the headlamp front panel (3).
6. Remove the two TORX screws (4) from the left side back panel (5) and remove the panel.

Mount Passing/Fog Lamp Switch

1. See Figure 6. Mark a spot one inch out from the inside edge (1) and halfway between the top and bottom edges (2) of the back panel (3) for the auxiliary lamp switch.
2. Drill a small lead hole at the marked spot. Enlarge the hole to 1/2 in. (13 mm) diameter to mount the switch.
3. See Figure 12 and Table 2. Attach the adhesive "SPOT" label (27 or 31) from the kit around the switch mounting hole.
4. Remove the knurled nut on from the switch (14) and mount the switch in the hole. With the knurled nut, secure the switch with the lever in OFF position.

NOTE

See Figure 8. The switch is in the OFF position when the power wire lead (Y) is on the motorcycle side and the toggle lever is down.

5. Set the back panel aside for later installation.

Assemble Lightbar

1. See Figure 12 and Table 2. Obtain from the kit, the lightbar (18), the left (25 or 29) and right (26 or 30) turn signal assemblies, two spotlamp housings (11), two turn signal adapters (9), 2 adjustment collars (28) and two conical lock nuts (5).

- On a workbench, install the turn signal assemblies through the adapters and the spotlight housings on the lightbar. The turn signals will be mounted to the lightbar with the wire leads facing inboard. See Figure 10.
- Slip on the adjustment collars, thread on the conical lock nuts and orient the spotlight housings and turn signal assemblies toward the front. Finger tighten the conical nuts.

NOTE

After aligning the headlamp, the spotlight beams will be adjusted to align with the headlamp beam. After the spotlight beams are aligned the conical lock nuts will be torqued to specification.

- See Figure 12 and Table 2. Wrap the piece of brown tape from the kit around the right side (V/BN) wire lead to identify the right turn signal power lead.
- See Figure 12 and Table 2. Obtain from the kit, wiring conduit (7), and 6-place connector housing (3) and 2-place connector housing (4).
- See Table 1. Snap the spotlight wire lead sockets into the cavities in the kit 2-place connector housing.
- Bundle and thread the wire leads from both the spotlight housing and the turn signals through the conduit.
- See Figure 7. The two grey and black (GY/BK) leads (2) are looped and turned back out of the conduit (1) before the cable straps (3) are tighten around the conduit.
- Tighten the conduit at each end with a cable strap.

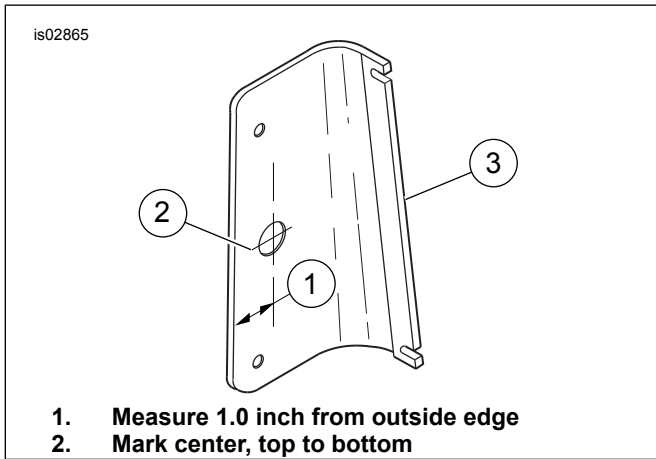
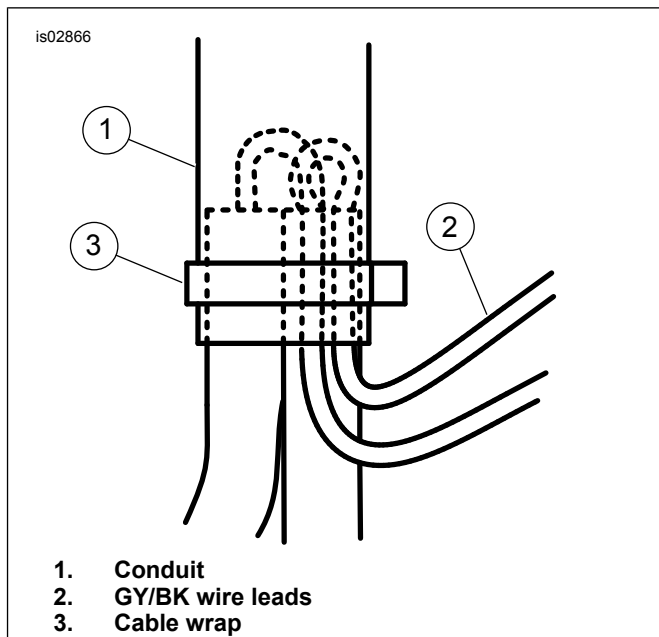
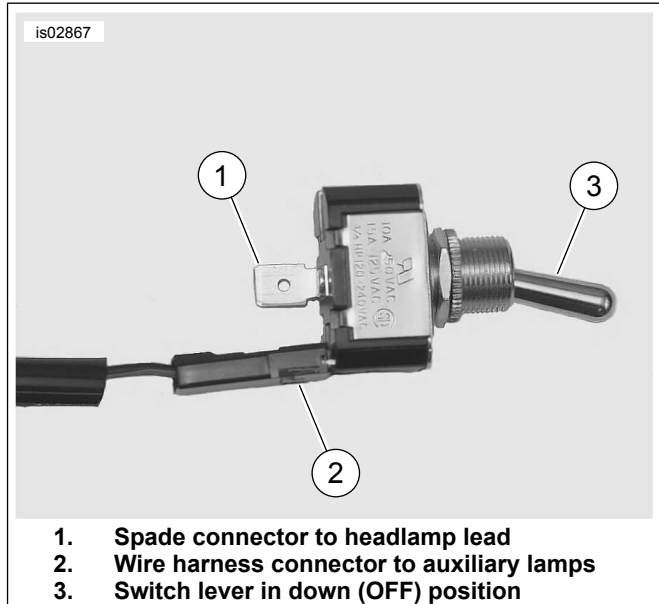

Figure 6. Switch hole location



- Conduit
- GY/BK wire leads
- Cable wrap

Figure 7. GY/BK Leads Looped and Turned Back



- Spade connector to headlamp lead
- Wire harness connector to auxiliary lamps
- Switch lever in down (OFF) position

Figure 8. Auxiliary Lamp Switch

- Refer to the listing below. Snap the wire lead sockets into the numbered cavities in the kit 6-place connector housing.

Table 1. Models

Cavity	Color	Left/Right	Notes
1	GY/BK	R	
2	GY/BK	L	

Connector Method

NOTE

These positions will match to the correct cavity positions on all Softails. The colors of the vehicle turn signal wires, however, vary by model year.

1. Make note of the wire colors and positions in each cavity of the six-place Multilock socket housing. Snap the terminals into the connector and insert in proper cavities of socket from kit as noted below.

2011 Softail 6-place connector on vehicle has the following cavities/colors:

Cavity - Color

- 1 - Black = Ground
- 2 - Blue with Orange Stripe = Right Turn
- 3 - Blue = Position (Running) Light in Turn Signal
- 4 - Blue = Position (Running) Light in Turn Signal
- 5 - Blue with Pink Stripe = Left Turn
- 6 - Black = Ground

2010 & Earlier Softail 6-place connector on vehicle has the following cavities/colors:

Cavity - Color

- 1 - Black = Ground
- 2 - Brown = Right Turn
- 3 - Blue = Position (Running) Light in Turn Signal
- 4 - Blue = Position (Running) Light in Turn Signal
- 5 - Violet = Left Turn
- 6 - Black = Ground

Installing the Lightbar

1. See Figure 12 and Table 2. Place a flat washer (17) on the 1-3/8 in. bolts (19) from the kit.
2. Fit the lightbar assembly and chrome front panel (16). Route the turn signal wires through the slots in the chrome front panel.
3. Thread in a flat washer and bolt loosely into the two top mounting holes in the lightbar and through the slots in the right back panel.
4. Route the turn signal harness to right side of the motorcycle.
5. Route the headlamp harness through the top hole in the chrome front panel and to the left side of the motorcycle.

NOTE

The chrome front panel should overlap the rear panels. The left rear panel will be installed behind the chrome front panel.

6. Place a flat washer (17) on the 1 in. bolts (20) from kit.
7. Insert bolts through the lower holes in each side of the lamp bracket. Thread in and finger tighten the bolts into the bottom holes of the chrome front and rear panels.
8. Mate the right side turn signal connector [31].
9. Mate the left side headlamp connector [38].

10. Mate the passing lamp switch jumper harness connector (15) to the 2-place connector from the lightbar wiring.
11. Holding up the left side back panel, press the wire harness jumper onto the lower spade connector on the auxiliary lamp switch.
12. Locate the power lead (Y) from the head lamp and press the spade connector onto the vertical spade on the auxiliary lamp switch.
13. Fitting the left back panel under the chrome front panel, thread in and tighten the two back panel screws to 20-30 **in-lbs** (2.3-3.3 Nm).

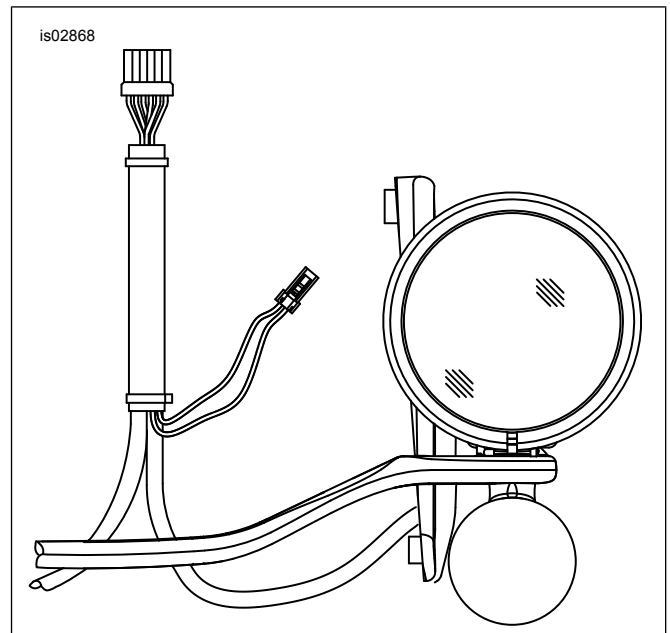

Figure 9. Assembled Lightbar and Wiring

14. Tighten the 4 bolts to 19 ft-lbs (26 Nm).
15. Assemble lamp bezel rings (10), screws (21) and nuts (2). The screw heads should be on the outside of the bezel rings when they are installed on the motorcycle.
16. Purchase the auxiliary lamps separately and obtain the jumper wires (12) and nesting rings (13) from the kit.
17. Connect the jumper wire to the passing lamp wire coming from the turn signal.
18. Connect the spade terminals to the lamp. Lamp terminals are not power/ground dependent.
19. Temporarily fit the lamp and nesting ring to the housing and clamp the assembly to the housing with the bezel ring.

NOTE

Tab on nesting ring engages the notch in the lamp housing.

Return Motorcycle to Service

1. Pull fuel tank forward into position aligning the mounting flange hole to the frame hole.

2. From left, loosely install screw and washer through tank mounting flange, bushings, grommets, and frame. Thread on washer and acorn locknut on right.
3. At rear of tank, verify that rubber grommet and metal insert are protruding through frame. Metal insert has flats on bottom for positioning.
4. Verify that rubber ring is in place around grommet and insert and lower fuel tank tab over insert.
5. Install washer and rear TORX screw through tab at rear of fuel tank. Tighten to 18-22 ft-lbs (24.4-29.8 Nm).
6. Tighten front acorn nut to 28-32 ft-lbs (38.0-43.4 Nm).
7. Mate fuel sender connector on top plate.
8. Press fuel vent line at front of tank.
9. Position console and attach with washer and acorn nut. Tighten to 80-100 in-lbs (9.0-11.3 Nm).
10. **For FLSTF (carbureted):** Install fuel line.

⚠ WARNING

To prevent spray of fuel, be sure quick-connect fittings are properly mated. Gasoline is extremely flammable and highly explosive, which could result in death or serious injury. (00268a)

11. **For FLSTFI (EFT):** Snap on the quick connect fuel line.
12. Connect the negative battery cable.

⚠ WARNING

The automatic-on headlamp feature provides increased visibility of the rider to other motorists. Be sure headlamp is on at all times. Poor visibility of rider to other motorists can result in death or serious injury. (00030b)

13. Test the following lights:
 - a. Turn signals.
 - b. Auxiliary lamp switch and lamps.
 - c. Headlamp for high and low beams.

NOTE

The auxiliary lamps are OFF when the high beams are ON.

⚠ WARNING

After installing seat, pull upward on seat to be sure it is locked in position. While riding, a loose seat can shift causing loss of control, which could result in death or serious injury. (00070b)

14. Refer to the Owner's Manual, and follow instructions to install the seat.

Headlamp and Auxiliary Lamp Adjustment

1. As required, adjust tire air pressure to specifications.
2. See Figure 10. Park motorcycle on level pavement in a low light area 25 ft (7.6 m) (1) from wall (measured from point directly below front axle).
3. Draw a horizontal alignment line 35 in. (0.9 m) (2) above floor on wall.
4. With motorcycle perpendicular (90°) to wall, follow the perpendicular line and draw a cross hair (a vertical alignment line) on the horizontal alignment line.
5. To simulate normal ride height, load motorcycle with rider and intended load and stand motorcycle upright with handlebars squared. Turn ON the ignition and switch on the high beam.

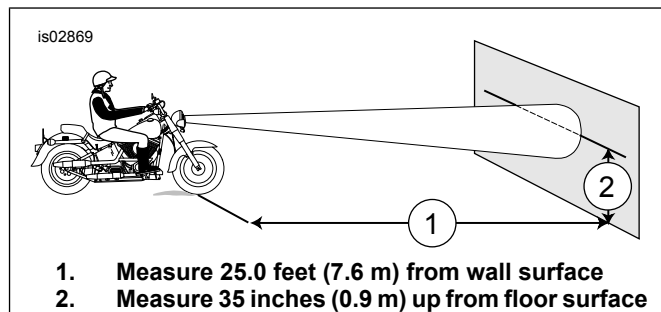

Figure 10. Horizontal Alignment Line

6. Using the horizontal and vertical adjusting bolts, adjust headlamp until the broad flat beam pattern is:
 - a. Centered vertically on the alignment line with equal areas above and below the horizontal line.
 - b. Centered horizontally with equal area left and right of the vertical line.
7. When aligned, tighten the headlamp adjustment bolts:
 - a. Horizontal to 30-35 ft-lbs (40.7-47.5 Nm).
 - b. Vertical to 35-45 ft-lbs (47-61.0 Nm).
8. With the auxiliary lamps in line with the headlamp lens, measure from the horizontal centerline of the headlamp to the horizontal centerlines of the auxiliary lamps and then from the vertical centerline of the headlamp to the vertical centerlines of the auxiliary lamps.
9. Using the measurements, draw crosshairs on the wall.
10. Under load, turn on high beam to verify headlamp alignment then switch to low beam.
11. See Figure 11. Turn ON the auxiliary lamps, cover headlamp and left auxiliary lamp and by hand turn right auxiliary lamp until beam pattern (2) fits the right cross hair extensions.

12. Cover headlamp and right auxiliary lamp and by hand turn left auxiliary lamp until beam pattern (3) fits the left cross hair extensions.

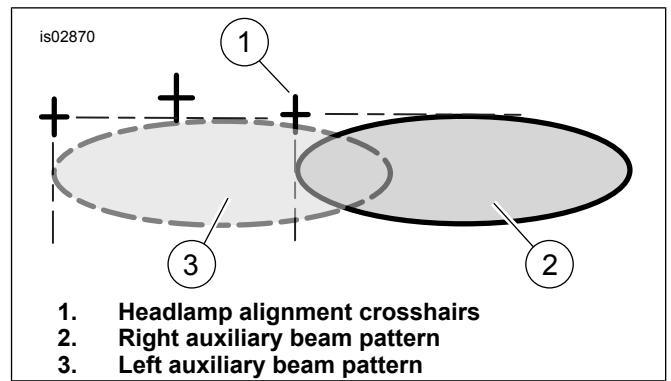

Figure 11. Auxiliary Lamp Beam Pattern

13. Remove right and left bezels and spotlamps and tighten conical lock nuts to 15-18 ft-lbs (20.3 to 24.4 Nm).

SERVICE PARTS

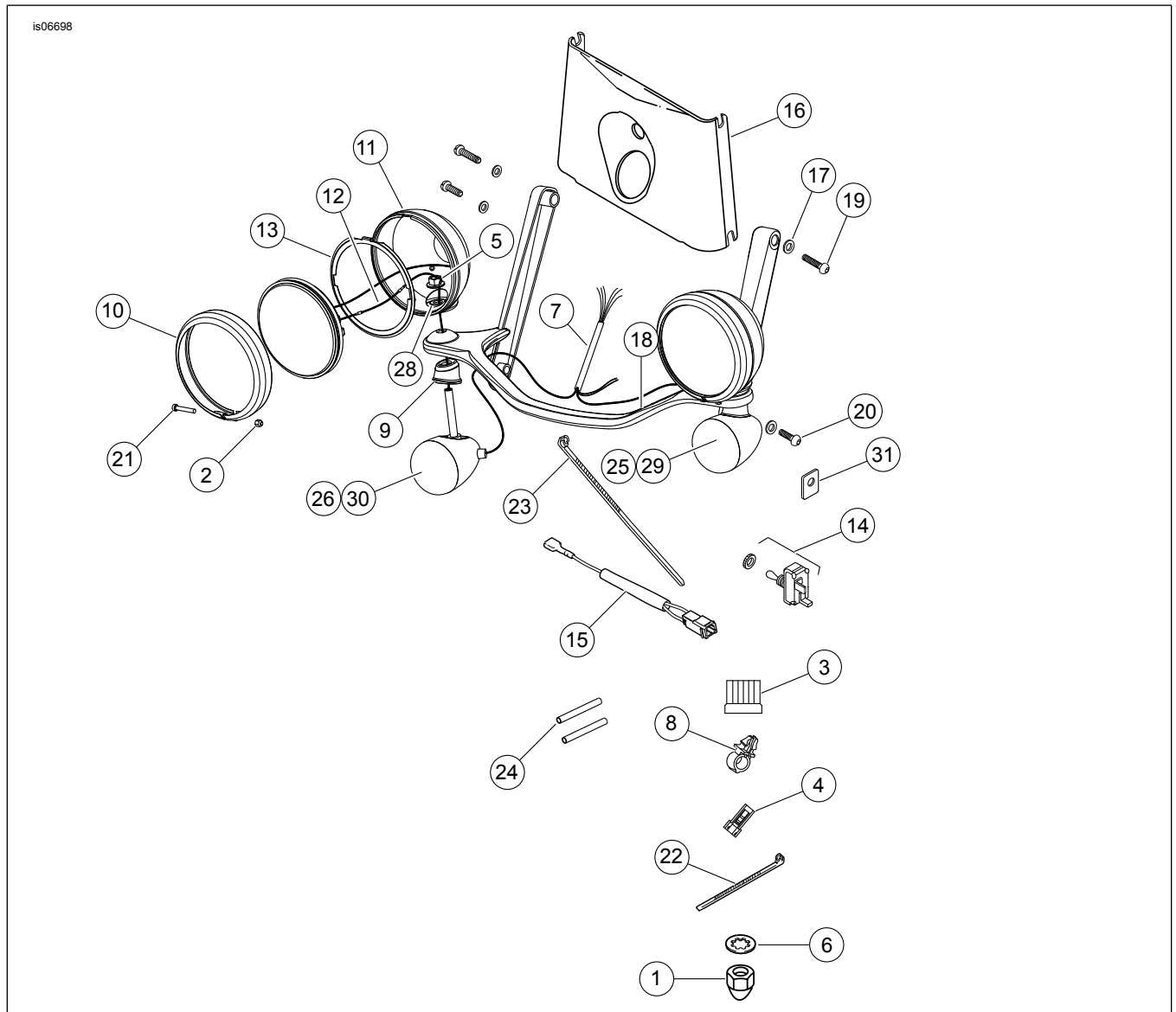

Figure 12. Service Parts: Deluxe Auxiliary Lamp Kits

Table 2. Service Parts Table

Item	Description (Quantity)	Part Number
Parts Common to both Kit Numbers 68670-05 and 68669-05		
1	Acorn nut, 5/16-18 (2)	7736
2	Nut, 8-32 (2)	7606
3	Housing, 6-way	73156-96BK
4	Housing, 2-way	73152-96BK
5	Nut, Keps conical washer (2)	7137
6	Lock washer, internal tooth, 5/16 I.D. (2)	7127
7	Conduit	7061'5-05
8	Clip, handlebar wire retainer (4)	70345-84
9	Aadapter, turn signal (2)	68840-05
10	Bezel ring (2)	68725-62A
11	Spotlamp housing (2)	68719-05
12	Wire jumper (2)	68337-05
13	Nest ring (2)	68331-02
14	ON/OFF switch	67858-89
15	Harness	67615-96
16	Chrome front panel	67605-05
17	Washer, flat (4)	6109
18	Lightbar	58092-05
19	Bolt, button hd hex socket, 1-3/8 inch (2)	4482
20	Bolt, button hd hex socket, 1.0 inch (2)	4481
21	Screw, fillister hd, 8-62 (2)	3383
22	Cable strap (2)	10065
23	Cable strap (4)	10006
24	Heat shrink tube (2)	72411-97
Parts Found in Kit No. 68669-05 only		
25	Turn signal assembly DOM, left	69221-05
26	Turn signal assembly DOM, right	69220-05
27	Spotlight label	68619-83
28	Collar, spotlight adjustment (2)	68673-05
Parts Found in Kit No. 68670-05 only		
29	Turnsignal assembly HDI, left	69223-05
30	Turnsignal assembly HDI, right	69222-05
31	Spotlight label	68731-98