



# INSTRUCTIONS

J05005

2013-06-27



## LED HEADLAMP KIT

### GENERAL

#### Kit Number

73391-10A, 67700042A, 67700189

#### Models

For model fitment information, see the P&A Retail Catalog or the Parts and Accessories section of [www.harley-davidson.com](http://www.harley-davidson.com) (English only).

#### Additional Parts Required

##### ⚠ WARNING

Rider and passenger safety depend upon the correct installation of this kit. Use the appropriate service manual procedures. If the procedure is not within your capabilities or you do not have the correct tools, have a Harley-Davidson dealer perform the installation. Improper installation of this kit could result in death or serious injury. (00333b)

##### NOTE

This instruction sheet references service manual information. A service manual for your model motorcycle is required for this installation and is available from a Harley-Davidson dealer.

This headlamp kit requires up to 3.75 A current from the electrical system. This may be less than the OE (original equipment) electrical draw which may be 5-6 A.

Separate purchase and installation of additional parts or accessories may be required for proper installation of this kit on your model motorcycle. See the P&A Retail Catalog or the Parts and Accessories section of [www.harley-davidson.com](http://www.harley-davidson.com) (English only) for a list of required parts or accessories for your model.

#### Kit Contents

There are no service parts available for this kit.

### REMOVAL

1. Refer to the service manual and follow the instructions given to perform these generalized steps:
  - a. Disconnect negative battery cable.
  - b. Remove the headlamp.
  - c. Retain the mounting ring and screws for installation.
  - d. Disconnect the headlamp bulb from the motorcycle harness connector block. Discard the headlamp.
  - e. **HDI Models:** Disconnect the position lamp connector from the harness connector.

### INSTALLATION

##### ⚠ WARNING

To prevent accidental vehicle start-up, which could cause death or serious injury, disconnect negative (-) battery cable before proceeding. (00048a)

1. **2014 and later Touring Models:** See the P&A Retail Catalog or the Parts and Accessories section of [www.harley-davidson.com](http://www.harley-davidson.com) (English only) for a list of required parts or accessories for your model.
2. Plug the headlamp connector of the LED headlamp into the wire harness connector block inside the headlamp bucket.
3. See the service manual and follow the instructions to install the headlamp.

##### ⚠ WARNING

After installing seat, pull upward on seat to be sure it is locked in position. While riding, a loose seat can shift causing loss of control, which could result in death or serious injury. (00070b)

4. Refer to the service manual and follow the instructions given to connect the negative battery cable and install the seat.
5. Test the headlamp for proper operation. Check the headlamp low beam for proper alignment.

### Headlamp Alignment Procedure

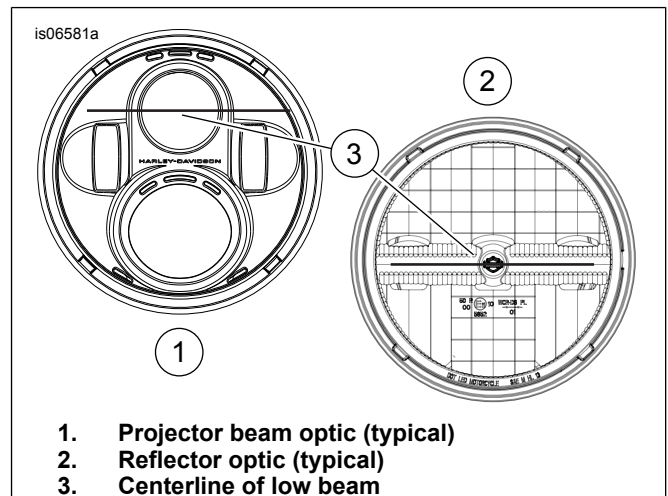

Figure 1. Headlamp Configuration

**NOTE**

Because of the differences between an LED headlamp and a halogen headlamp, the alignment procedure is performed on both the **low beam** and the **high beam**. Read these instructions thoroughly to properly align the LED headlamp.

1. Verify that front and rear tire inflation pressures are correct and that the suspension is adjusted to the weight of the principal rider. See the owner's manual.
2. Fill fuel tank or add an equal amount of ballast.
3. See Figure 2. Position motorcycle so that front axle is 25 feet (7.6 meters) (3) from wall.

**NOTE**

As the weight of the rider will compress the suspension slightly, have a person whose weight is approximately the same as that of the principle rider sit on the motorcycle.

4. See Figure 1. With vehicle laden and upright, point the front wheel straight forward at wall and measure the distance from the floor to the center of the **low beam** lens (3). Record this measurement.
5. See Figure 2. Draw a horizontal line on the wall at (5) on the wall that is the same measurement as the measurement recorded in Step 4.
6. Draw a vertical line (2) off of the perpendicular line (1) so that it crosses through the horizontal line drawn in the previous step.
7. If equipped with additional lighting such as passing lamps, verify that those lights are OFF during the alignment procedure.

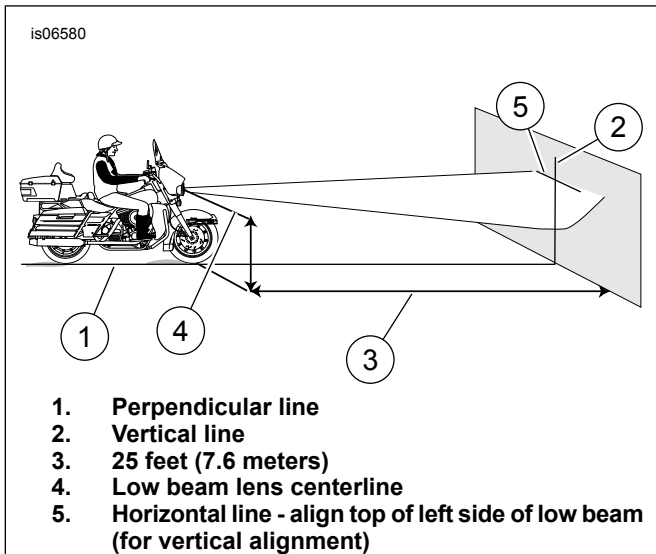

**Figure 2. Checking Headlamp Alignment**

**Alignment of High Beam (Left-to-Right Alignment)**

1. Verify that the headlamp lens is perpendicular to the front forks for proper left-to-right alignment.
2. See Figure 3. With vehicle laden and upright, point the front wheel straight forward at wall.
3. Turn on the **high beam** and align the **high beam** hot spot with the vertical line (3).

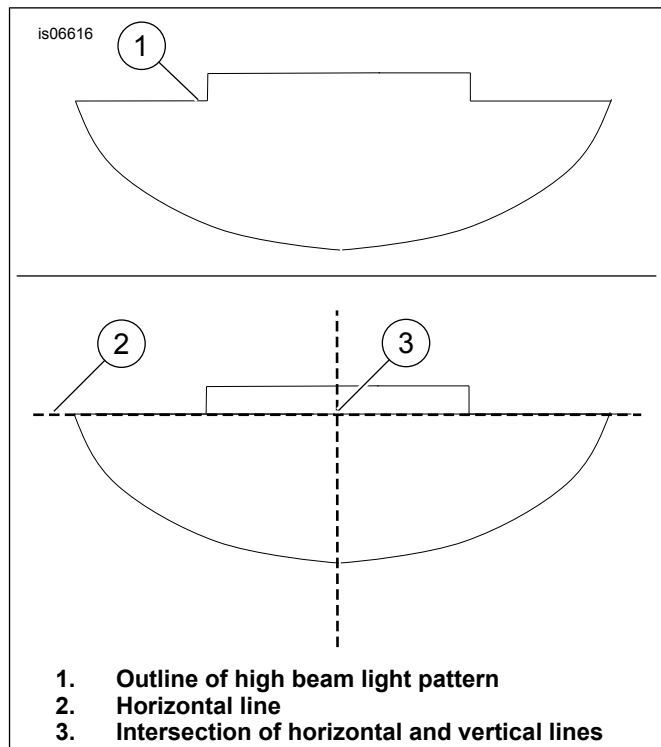

**Figure 3. Alignment of Headlamp High Beam**

**Alignment of Low Beam (Vertical Alignment)**

1. See Figure 4. Align the left side of the horizontal line of the **low beam** light pattern (3) with horizontal line (2) drawn on the wall. If necessary, adjust the headlamp position by following the adjustment procedure in the service manual.

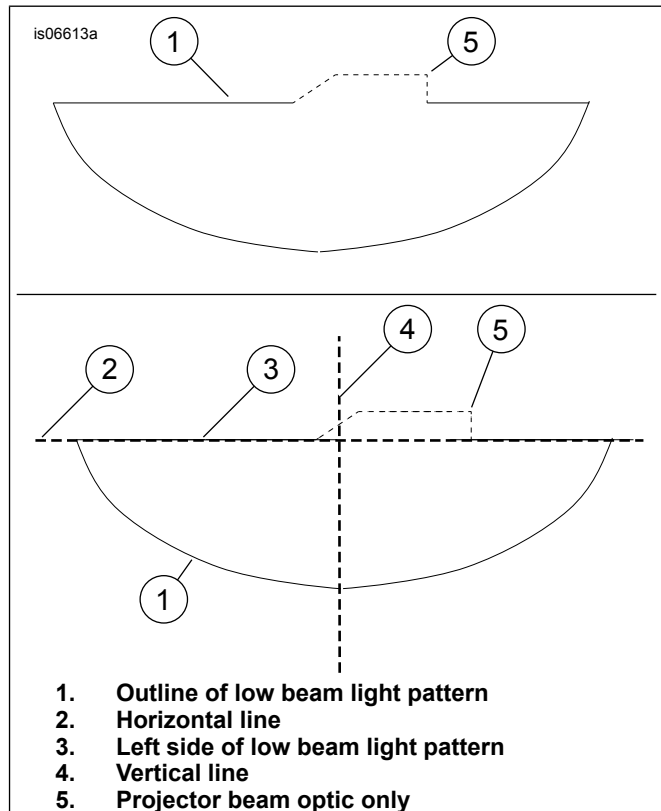

**Figure 4. Alignment of Headlamp Low Beam**