



# INSTRUCTIONS

J05137

2021-04-27



## QUICK RELEASE WINDSHIELD LOCKING CLAMPS

### GENERAL

#### Kit Number

57400006, 57400007, 57400008, 57400536, 57400537

#### Models

For model fitment information, see the P&A Retail Catalog or the Parts and Accessories section of [www.harley-davidson.com](http://www.harley-davidson.com) (English only).

#### ▲ WARNING

Rider and passenger safety depend upon the correct installation of this kit. Use the appropriate service manual procedures. If the procedure is not within your capabilities or you do not have the correct tools, have a Harley-Davidson dealer perform the installation. Improper installation of this kit could result in death or serious injury. (00333b)

#### Kit Contents

See Figure 2 and Table 1.

There are no Service Parts available with these kits.

### INSTALLATION

#### NOTE

These locking clamps replace a standard quick release clamp already assembled to a windshield or used for assembling a windshield being installed for the first time.

1. Remove the windshield and place face down on a clean, soft surface with the mount brackets facing upward.
2. Remove the clamp and hardware from packaging. The locking clamp should be unlocked at time of installation. Note that the upper clamps can be identified by extensions that point upwards.
3. See Figure 1. Assemble the clamp assemblies and hardware stacks.

#### ▲ WARNING

The cupped side of the Belleville (cone) washers must face each other and sandwich the windshield mount brackets at each mount point. Failure to orient washers correctly can reduce windshield's ability to break away in a collision, which could result in death or serious injury. (00422b)

4. One clamp at a time, with the clamp facing upward and inboard of the windshield bracket (2), tighten the shoulder bolts (1) enough to hold the clamp orientation to the windshield during mounting of the windshield to the motorcycle. The bolts will be fully tightened later.
5. Make sure all four clamps are in the open position, then bring the windshield (with the clamp side away from you) to the front of the motorcycle.
6. Continue with the installation using the instruction sheet.

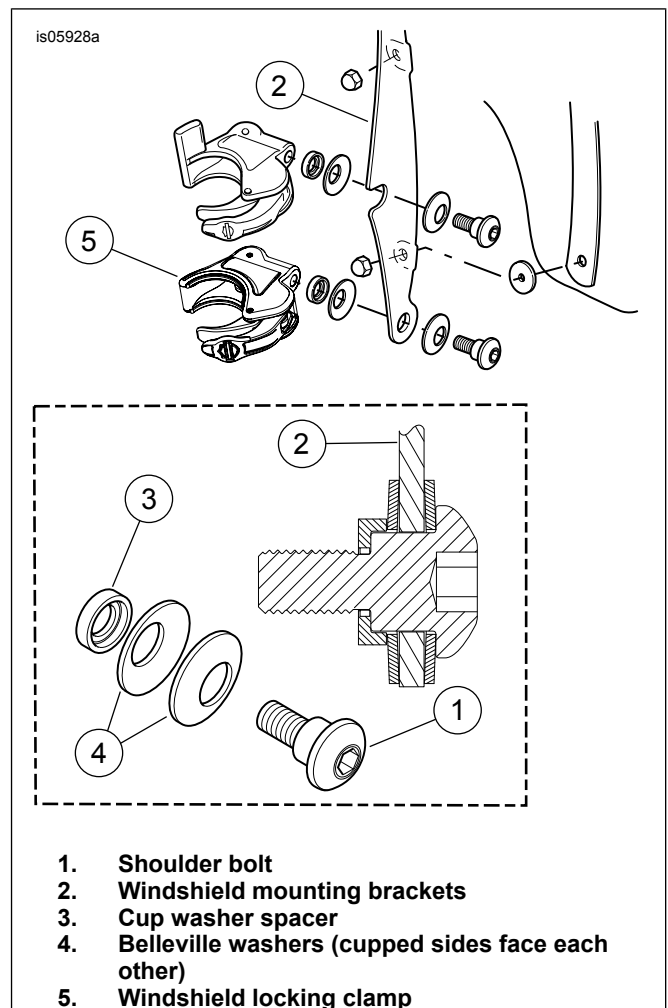

1. Shoulder bolt
2. Windshield mounting brackets
3. Cup washer spacer
4. Belleville washers (cupped sides face each other)
5. Windshield locking clamp

Figure 1. Windshield Mounting Clamp

### Locking and Unlocking the Latch

#### NOTE

Make sure the key is not in the latch during installation of the locking clamp.



Key is not required to lock the latch.

1. Locking the latch: When the clamp is installed, push the spring operated lock.

**NOTE**

Keep the key aligned with the post of the release button while unlocking the latch to avoid bending or breaking the key or the shaft.

2. Unlocking the latch: Insert the key in the lock and turn it gently clockwise 1/8 turn. Turn the key counterclockwise 1/8 turn and remove the key.

**KIT CONTENTS**

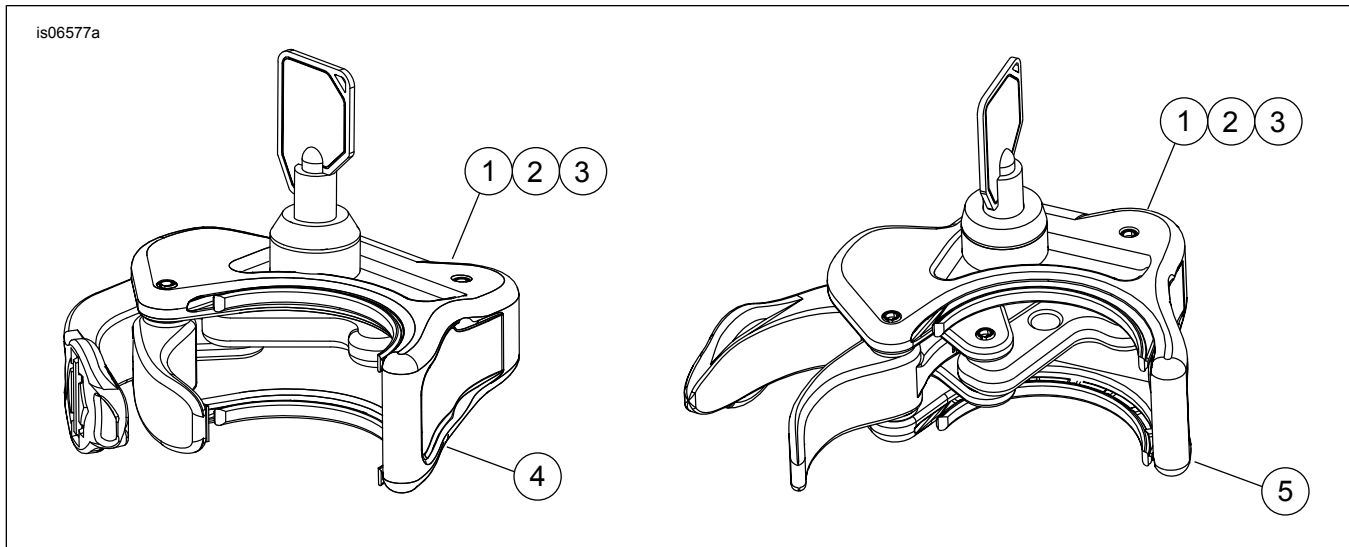

**Figure 2. Locking Quick Release Windshield Clamps**

**Table 1. Kit Contents**

Item	Description (Quantity)	Kit Number
1	Quick release windshield lock, 39 mm	57400006, 57400536
2	Quick release windshield lock, 41 mm	57400007
3	Quick release windshield lock, 49 mm	57400008, 57400537
4	Clamp closed	
5	Clamp open	