



INSTRUCTIONS

J05487

2012-07-20



FLHR VENTED WINDSHIELD KIT

GENERAL

Kit Number

57400024

Models

These kits fit 1994 and later FLHR models. Will also fit FLHRS models with separate purchase of Mounting Hardware Kit, Part Number 58221-04. (Stock on 2006 and later International FLHR models.)

Additional Parts Required

NOTE

A service manual for your model motorcycle is available from a Harley-Davidson dealer.

Kit Contents

See Figure 1 and Table 1.

INSTALLATION

1. Lower the windshield into position by carefully inserting the side brackets between the headlamp housing and the passing lamp supports until the bottom notches are seated on the lower grommets.

NOTE

Be sure that the notches on each bracket are firmly seated on a rubber grommet.

2. Standing at the front of the motorcycle, gently push the top of the windshield toward the rear until the upper notches fully engage the upper grommets.

3. Push down on the wireform latch springs until the springs overhang the rubber grommets.

NOTE

If some adjustment is necessary, loosen the retaining bolts and rotate the latch springs into the proper position.

CARE AND CLEANING

NOTE

Sunlight reflections off of the inside curvature of a windshield can, at certain times of the day, cause extreme heat build-up on motorcycle instruments. Exercise care in parking. Park facing the sun, place an opaque object over the instruments, or adjust the windshield to avoid reflections.

NOTICE

Use only Harley-Davidson recommended products on Harley-Davidson windshields. Do not use harsh chemicals or rain sheeting products, which can cause windshield surface damage, such as dulling or hazing. (00231c)

Do not clean Lexan[®] polycarbonate in hot sun or high temperature. Powdered, abrasive or alkaline cleanser will damage the windshield. Never scrape the windshield with a razor blade or other sharp instruments because permanent damage will result.

NOTE

Covering the windshield with a clean, wet cloth for about 15 minutes before washing will make dried bug removal easier.

Harley-Davidson Windshield Water Repellent Treatment Part Number 99841-01 is approved for use on Harley-Davidson Lexan[®] windshields.

SERVICE PARTS

is07116

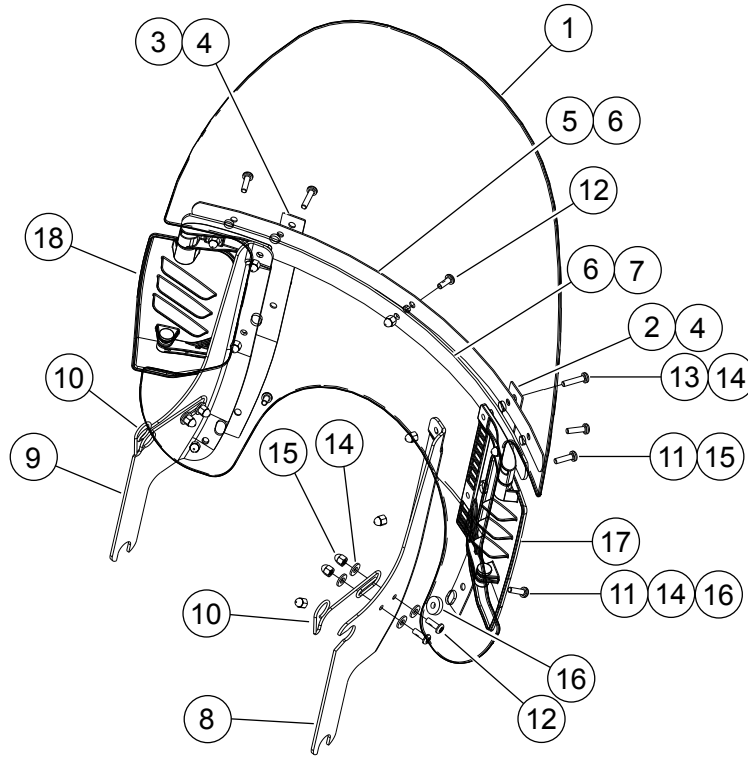

Figure 1. Service Parts: Vented Detachable Windshield

Table 1. Service Parts Table

Item	Description (Quantity)	Part Number
1	Windshield service kit	57400117
2	Outer RH vertical brace	58406-75A
3	Outer LH vertical brace	58408-75A
4	Outer vertical brace tape (2)	58417-77
5	Outer horizontal brace	57400047
6	Horizontal brace tape (2)	58416-77A
7	Inner horizontal brace	57400048
8	RH bracket	58084-94
9	LH bracket	58088-94
10	Spring latches (2)	38722-94
11	Panhead TORX® screws (6)	2452
12	Panhead TORX screws (5)	2921
13	Panhead TORX special screws (2)	2488
14	Plain washers (10)	6119
15	Acorn nuts (13)	7651A
16	Spacer (2)	12400013
17	Windshield vent, right	57400029
18	Windshield vent, left	57400030