



INSTRUCTIONS

J05154

2011-03-21



BOOM! AUDIO BASS BOOSTER TOUR-PAK PORT KIT

GENERAL

Kit Number

76000013

Models

For model fitment information, see the P&A retail catalog or the Parts and Accessories section of www.harley-davidson.com (English only).

This kit is not compatible with the BOOM! Audio High Output Sound System (Part No. 76418-06 or 76418-06A).

Additional Parts Required

A Tour-Pak[®] and rear speakers are required for proper installation of this kit.

Models with BOOM! Audio Amplifier (Part No. 76000068) will require a software upgrade using Digital Technician II by a Harley-Davidson dealer. See the SERVICE PARTS section for upgrade information.

Kit Contents

See Figure 1 and Table 1.

PREPARATION

NOTE

For vehicles equipped with security siren:

- Verify that the Hands-Free Fob is present.
- Turn the ignition key switch to IGNITION.

⚠ WARNING

To prevent accidental vehicle start-up, which could cause death or serious injury, remove main fuse before proceeding. (00251b)

1. Refer to the owner's manual and follow the instructions to remove the main fuse.

INSTALLATION

NOTE

The Tour-Pak does not need to be removed from the vehicle to perform this installation.

1. Open the Tour-Pak lid and remove all items from the Tour-Pak base.
2. **Models equipped with mat:** Remove the mat. **Models equipped with liner:** Open the map pocket, and remove the acorn nuts with flat washers. Remove the map pocket and liner.

3. Remove four screws from the left-side speaker grille on the Tour-Pak. Remove the speaker grille from the speaker pod.
4. Remove the speaker from the speaker pod. Carefully pull the two socket terminals from the speaker spade contacts.
5. Remove the grommet, and draw the rear speaker/passenger controls connector out of the speaker pod. Separate the connector halves.
6. Repeat Steps 3 through 5 for the right-side speaker.
7. See Figure 1. Get the drill template (3) from the kit. **If NOT equipped with power port: If equipped with power port:**
 - a. Remove one speaker pod mounting screw and flat washer.
 - b. Align the drill template on the inside of the Tour-Pak with the speaker pod holes, and hold in place with the mounting screw and washer.
 - c. Repeat for the remaining template mounting holes.
 - d. Remove the two screws and flat washers to free the power port from the Tour-Pak.
 - e. Align the drill template on the inside of the Tour-Pak with the power port holes, and hold in place with the mounting screws and washers.
 - f. Repeat with the top speaker pod mounting screw and flat washer.

NOTE

Tighten the screws enough to hold the speaker pod in place as the pilot hole is drilled.

8. Where indicated on the template, drill a 5 mm (3/16 in) diameter pilot hole through the Tour-Pak wall and speaker pod.
9. Remove the screws and speaker pod, and set aside. Turn the template over, and repeat Steps 7 and 8 on the left side of the Tour-Pak.

NOTE

Hole size will affect the fitment of the ports. The hole saw needs to be sharp.

10. Carefully drill a 51 mm (2 in) diameter hole with a sharp hole saw, at the pilot location, through each speaker pod and in both locations on the Tour-Pak wall.



11. Temporarily install the Tour-Pak liner (if equipped), and mark the location of the 51 mm (2 in) diameter holes on the outside of the liner. Remove the liner, and carefully cut the two holes in the liner front wall.
12. Get one of the bass boost port gaskets (2) from the kit, and position over the mounting holes on the speaker pod, between the pod and Tour-Pak. Loosely install the original screw and flat washer through the top hole in the Tour-Pak wall and gasket, and into the crimp nut in the speaker pod mounting hole. **If equipped with power port:** Place the spacer (4) from the kit behind the power port. Loosely install the **new**, longer screws (5) and flat washers (A) through the power port, spacer, and the bottom holes in the Tour-Pak wall and gasket, and into the crimp nuts in the speaker pod mounting holes. **If NOT equipped with power port:** Loosely install the original screws and flat washers (A) through the bottom holes. **ALL applications:** Tighten the screws to 2.8–4 N·m (25–35 in-lbs)
13. Install a rubber grommet (6) into the speaker wire entry hole in the speaker pod wall.
14. Repeat Steps 12 through 13 on the opposite side of the Tour-Pak.
15. **Models equipped with mat:** Install the mat. **Models equipped with liner:** Install the Tour-Pak liner. Open the liner map pocket, and install the acorn nuts with flat washers. Tighten securely.
16. Get the bass boost ports (1) and O-rings (7) from the kit.

NOTE

DO NOT install the O-rings on the port tubes at this time.

17. Temporarily install the bass boost ports by inserting them, from inside the Tour-Pak, into the 51 mm (2 in) diameter holes. Mark the liner for additional trimming if the ports do not sit flat in the holes.

18. Install an O-ring onto the groove on the outside of the port tube. Use the innermost groove on the port tube for the OE models with or without a Tour-Pak liner, and the outer groove for the thicker CVO liner. Rotate the bass boost port so the Harley-Davidson text is at the top. Push the port **firmly** through the liner and Tour-Pak wall, and into the speaker pod.
19. Install the two spade terminals onto the speaker spade contacts. Different-sized spade contacts prevent improper assembly.
20. Position the speaker gaskets (8) behind the speakers and, with the spade contacts at the bottom, install the speakers into the speaker pods.
21. Align the holes in the speaker with those in the speaker pod. Align the holes in the grille with those in the speaker.
22. Install the four screws and alternately tighten in a crosswise pattern.
23. Close and latch the Tour-Pak lid.

RETURN TO SERVICE

NOTE

*Verify that the ignition key switch is in the OFF position **before** installing the main fuse.*

1. Refer to the owner's manual and follow the instructions to install the main fuse.
2. Turn the ignition key switch to ON, but do not start the motorcycle.
3. Test the sound system for proper speaker function.

NOTE

*In order to experience the increased bass response provided by the BOOM! Audio Bass Booster Tour-Pak Ports on **models with the BOOM! Audio Amplifier**., a system reflash using Digital Technician II at a Harley-Davidson dealer will be required. See the SERVICE PARTS section for software upgrade information.*

The bass ports use the space inside the closed Tour-Pak to provide the increased bass response. An open Tour-Pak lid or items in the Tour-Pak may affect bass response.

SERVICE PARTS

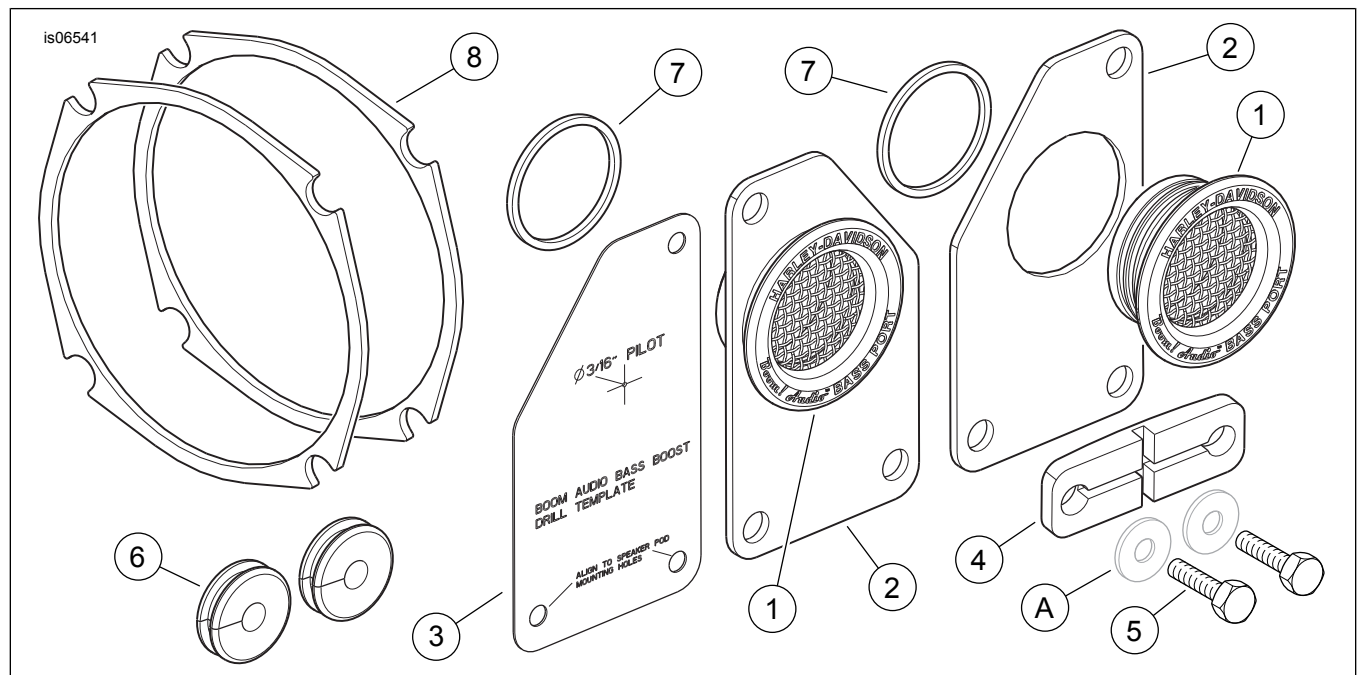

Figure 1. Service Parts, BOOM! Audio Bass Booster Tour-Pak Port Kit

Table 1. Service Parts

Item	Description (Quantity)	Part Number
1	Port, bass boost (2)	Not sold separately
2	Gasket, bass boost port (2)	Not sold separately
3	Template, bass boost port drilling	Not sold separately
4	Spacer, power port	Not sold separately
5	Screw, 1/4-20 x 31.8 mm (1.25 in) long (2)	3993
6	Grommet (2)	Not sold separately
7	O-ring (2)	Not sold separately
8	Gasket, speaker (2)	Not sold separately
Items mentioned in text, but not included in kit:		
A	OE flat washer (6)	

BOOM! AUDIO™ SOFTWARE UPGRADE

The purchase of this accessory entitles you to a specially developed sound equalization software that is used in conjunction with the Harley-Davidson BOOM! Audio Amplifier (Part No. 76000068). This unique equalization was designed to optimize the performance and sound response of the BOOM! Audio Bass Booster Tour-Pak Ports.

This special equalization **software** is available without charge from your dealer through Digital Technician II. Dealer labor rates may apply for the upgrade procedure.