



INSTRUCTIONS

J05421

2012-05-28



PREMIUM RIDE, HAND-ADJUSTABLE TOURING SHOCKS

GENERAL

Kit Number

54000008

Models

For model fitment information, see the P&A Retail Catalog or the Parts and Accessories section of www.harley-davidson.com (English only).

Additional Parts Required

Separate purchase of LOCTITE® 243 Threadlocker and Sealant - Blue (99642-97) for proper installation of this kit. Loctite is available from a Harley-Davidson dealer.

⚠ WARNING

Rider and passenger safety depend upon the correct installation of this kit. Use the appropriate service manual procedures. If the procedure is not within your capabilities or you do not have the correct tools, have a Harley-Davidson dealer perform the installation. Improper installation of this kit could result in death or serious injury. (00333b)

NOTE

This instruction sheet references service manual information. A service manual for your model motorcycle is required for this installation and is available from a Harley-Davidson dealer.

INSTALLATION

NOTE

Both OEM shocks must be removed before installing the shocks from this kit. To remove both shocks, place the motorcycle on a center stand with the rear wheel raised off the ground.

If you choose to save the air shocks, never lay the shock absorber down. Always keep the shock absorber upright to prevent oil from draining out through the compression fitting. Any loss of oil requires replacement of the shock absorber. The fitting can be sealed with a screw plug.

⚠ WARNING

Use caution when bleeding air from the suspension. Moisture combined with lubricant may leak onto the rear wheel, tire and/or brake components and adversely affect traction, which could result in death or serious injury. (00084a)

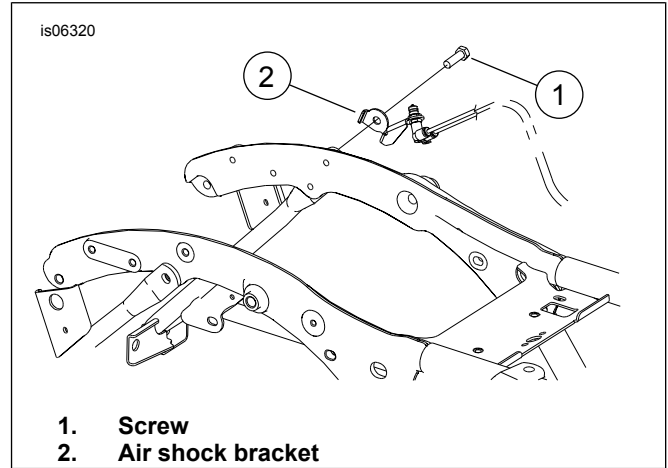

Figure 1. Remove Air Shock Bracket

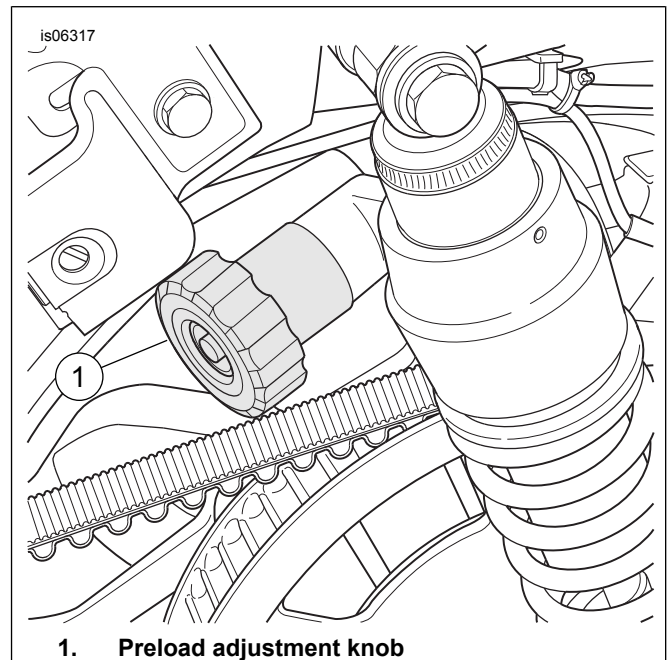

Figure 2. Preload Adjustment Knob

1. Refer to Rear Shock Absorbers in the service manual to remove the air suspension system and the air shocks.
2. See Figure 1. Remove screw (1) from the air valve bracket assembly and remove assembly. Save the air valve bracket assembly if you plan to reuse the air shocks. Install the screw to the frame rail and saddle bag support and tighten to 20.3–27.1 N·m (15–20 ft-lbs). If wire harness is secured to air shock bracket with a cable tie, remove cable tie. Install a new cable tie around wire harness and saddlebag support.

3. Install the lock washer to the lower shock bolt and then the flat washer and apply two or three drops of Loctite 243 to the bolt threads.
4. See Figure 3. Install the shock absorber (1) on the left side of the vehicle with the preload adjustment knob toward the front of the motorcycle, as shown in Figure 2, and start the bolt into the swingarm mount.
5. Install lock washer and flat washer to the upper shock bolt and apply two or three drops of Loctite to the thread bolts.
6. Tighten the upper and lower shock bolts to 47–54 N·m (35–40 ft-lbs).
7. Repeat steps 3, 5 and 6 for the right side shock absorber, oriented as shown in Figure 3.

NOTICE

Wipe all fingerprints off of exhaust system components after installation and before starting engine. Oil from hands can leave permanent marks on exhaust system finish. (00346a)

Shock Absorber Preload Adjustment

NOTE

The shock absorber preload can be adjusted for the weight the motorcycle is to carry. Increase preload to accommodate the total load on the motorcycle. Reduce the preload if carrying less weight.

1. Remove the left side saddlebag if installed.
2. See Figure 2. Rotate the preload adjustment knob counterclockwise until it stops. This is the minimum preload position.
3. Refer to Table 2. Rotate the preload adjustment knob clockwise the recommended number of turns to increase the preload for the total weight of the rider, passenger, cargo and added accessories. The knob will click after each full rotation.

KIT CONTENTS

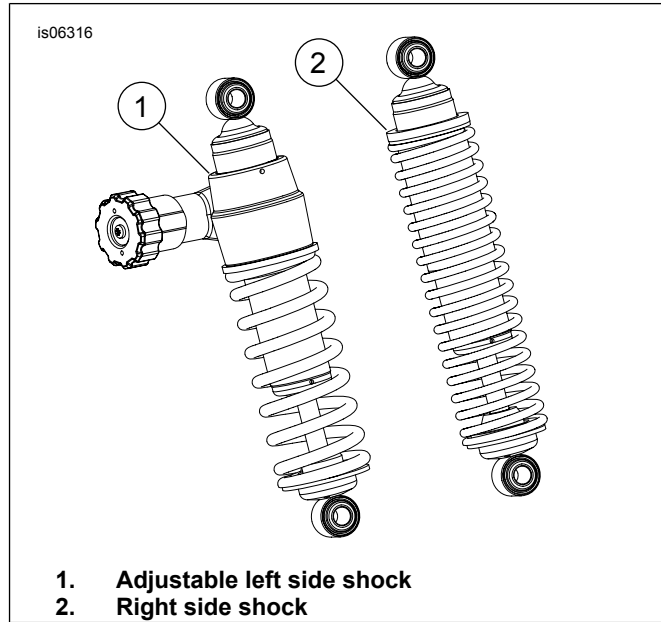

1. Adjustable left side shock
2. Right side shock

Figure 3. Adjustable Touring Shock Kit

Table 1. Service Parts: Adjustable Touring Shock Absorbers

Item	Description (Quantity)	Part Number
1	Shock absorber, left side	Not Sold Separately
2	Shock absorber, right side	Not Sold Separately

Table 2. Recommended Preload Settings

PRE-LOAD TURNS FROM MINIMUM	Without Tour-Pak		PRE-LOAD TURNS FROM MINIMUM	With Tour-Pak	
	LB	KG		LB	KG
0	Under 220	Under 100	0	Under 170	Under 170
1	220	100	1	170	77
2	230	104	2	180	82
3	240	109	3	190	86
4	250	113	4	200	91
5	260	118	5	210	95
6	270	122	6	220	100
7	280	127	7	230	104
8	290	132	8	240	109
9	300	136	9	250	113
10	310	141	10	260	118
11	320	145	11	270	122
12	330	150	12	280	127
13	340	154	13	290	131
14	350	159	14	300	136
15	360	163	15	310	141
16	370	168	16	320	145
17	380	172	17	330	150
18	390	177	18	340	154
19	400 to GVWR	181 to GVWR	19	350 to GVWR	159 to GVWR

Load includes the total weight of the rider, passenger, cargo and added accessories.