



# INSTRUCTIONS

J05590

2014-02-04



## DOCKING HARDWARE KIT

### GENERAL

#### Kit Number

52300285

#### Models

For model fitment information, see the P&A retail catalog or the Parts and Accessories section of [www.harley-davidson.com](http://www.harley-davidson.com) (English only).

This kit is also required when mounting a Two-Up Luggage Rack Kit (Part No. 50300071 or 50300091).

#### Installation Requirements

Loctite® 243 Medium Strength Threadlocker and Sealant - Blue (Part No. 99642-97) is required for proper installation of this kit. This item is available from a Harley-Davidson dealer.

#### ⚠ WARNING

**Rider and passenger safety depend upon the correct installation of this kit. If the procedure is not within your capabilities or you do not have the correct tools, have a Harley-Davidson dealer perform the installation. Improper installation of this kit could result in death or serious injury. (00308b)**

#### NOTE

*This instruction sheet refers to service manual information. A service manual for this year/model motorcycle is available from a Harley-Davidson dealer.*

#### Kit Contents

See Figure 3 and Table 1.

### INSTALLATION

#### NOTE

*Perform the following procedures on **one side at a time** to maintain fender alignment.*

1. See Figure 3. Remove and discard the **rearward** fender support screw.
2. Get a wide docking point (1), screw (2) and docking point spacer (3) from the kit.
3. Install the docking point, countersunk end (A) last as shown, onto the screw threads. Install the docking point spacer, tapered end (B) last, onto the threads.
4. Install the screw through the fender support, fender and into the fender mounting spacer (C). Tighten finger-tight.

5. Remove and discard the **forward** fender support screw on the same side of the vehicle.
6. Get a narrow docking point (4) and screw (2) from the kit.
7. Install the docking point onto the screw threads, tapered end last.
8. Apply a few drops of Loctite 243 - Blue to the first four threads of the screw.
9. Install the screw through the fender support, fender and into the fender mounting spacer (C). Tighten to 54.2 N·m (40 ft-lbs).
10. Repeat Steps 1-9 on the opposite side of the fender.

#### Check Docking Point Alignment and Tightness

1. Install a detachable accessory per the instructions in **that** kit. **If the detachable latches rotate smoothly:**
  - a. Remove the accessory.
  - b. See Figure 3. Remove the assembled screw (2), wide docking point (1) and docking point spacer (3) from the rear docking point position on each side.
  - c. Apply a few drops of Loctite 243 - Blue to the first four threads of each screw.
  - d. Install the assembled hardware to each side of the fender. Tighten screws to 54.2 N·m (40 ft-lbs).

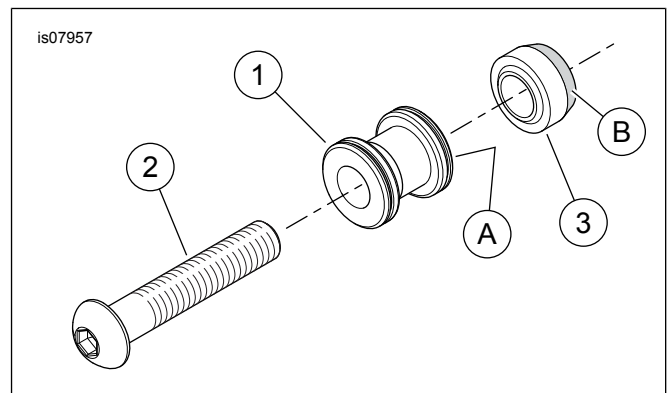

Figure 1. Initial Rearward Dock Installation



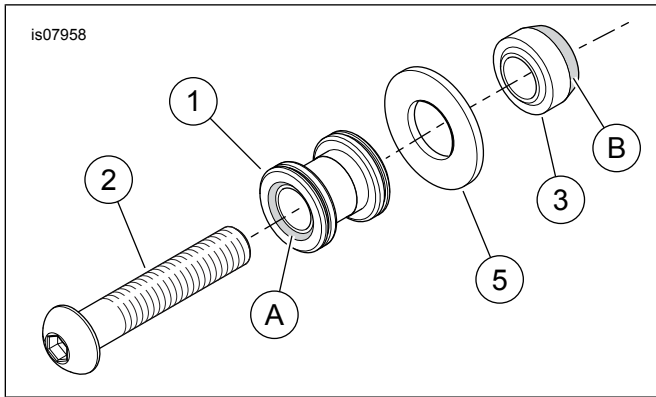

Figure 2. If Detachable Latches Do Not Rotate Smoothly

2. If the detachable latches DO NOT rotate smoothly:
  - a. Remove the accessory.
  - b. See Figure 3. Remove the assembled screw (2), wide docking point (1) and docking point spacer (3) from the rear docking point position on each side.
  - c. Remove the spacers from the screw threads. Remove the docking points.
  - d. Rotate the docking points 180 degrees. Install the docking points, countersunk end (A) **first**, onto the screw threads.
  - e. Get two spacer washers (5) from the kit. Install a spacer washer onto the threads of each screw.
  - f. Install the docking point spacers, tapered end (B) last, onto the threads.
  - g. Apply a few drops of Loctite 243 - Blue to the first four threads of each screw.
  - h. Install the screws through the fender supports, fender and into the fender mounting spacers (C). Tighten screws to 54.2 N·m (40 ft-lbs).
  - i. Install the detachable accessory.

## CARE AND MAINTENANCE

### Docking Point Maintenance

#### NOTE

*In time docking points wear, causing the mating detachable accessory to become loose and rattle. The fit can be tightened using the following procedure.*

1. Mark each docking point to indicate the current top position.
2. Remove the docking hardware.
3. Remove all existing threadlocking agent from the docking point fastener and mounting hole threads. Apply **new** Loctite 243 - Blue to the screw threads.
4. Rotate the docking points clockwise approximately 45 degrees from the previous position.
5. Tighten the docking hardware to the torque value indicated in the installation procedures.

This procedure can be repeated up to three times before replacement of the docking points is recommended.

## SERVICE PARTS

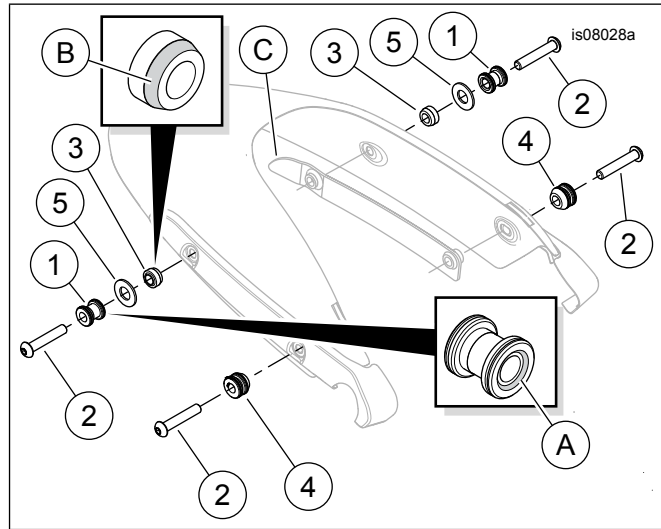

Figure 3. Service Parts, Docking Hardware Kit

Table 1. Service Parts

Item	Description (Quantity)	Part Number
1	Docking point, rear (wide) (2)	52300287
2	Screw, button head (4)	10200203
3	Docking point spacer (2)	Not sold separately
4	Docking point, front (narrow) (2)	52300286
5	Spacer washer (2)	12400102
<b>Items mentioned in text, but not included in kit.</b>		
A	Countersunk end of docking point	
B	Tapered end of docking point spacer	
C	Fender mounting spacer	