



INSTRUCTIONS

J05596

2012-06-22



SOFTAIL CARTRIDGE FRONT FORK KIT

GENERAL

Kit Number

45500141

Models

For model fitment information, see the P&A Retail Catalog or the Parts and Accessories section of www.harley-davidson.com (English only).

Additional Parts Required

Proper installation of this kit also requires the following special tools:

Fork Tube Holder (HD-41177)

Fork Seal/Bushing Tool (HD-34634)

Front Fork Oil Level Gauge (HD-59000B)

Front Fork Spring Compressing Tool (HD-45966)

Extension tool (HD-45966-1)

Proper installation of this kit may also require the replacement of the following parts:

Table 1. Replacement Parts

Item (Quantity)	Part Number
Slider bushing (2)	45940-84
Screw with copper crush washer, 6 mm (2)	45405-75A
Harley-Davidson® Type E Fork oil	99884-80

⚠ WARNING

Rider and passenger safety depend upon the correct installation of this kit. Use the appropriate service manual procedures. If the procedure is not within your capabilities or you do not have the correct tools, have a Harley-Davidson dealer perform the installation. Improper installation of this kit could result in death or serious injury. (00333b)

NOTE

This instruction sheet references service manual information. A service manual for your model motorcycle is required for this installation and is available from a Harley-Davidson Dealer.

Kit Contents

See Figure 9 and Table 2.

REMOVAL

1. Refer to the appropriate service manual and remove the front fender, wheel and brakes and nacelle.

2. Refer to the appropriate service manual and remove the front forks.

RIGHT SIDE

Fork Disassembly

1. See Figure 1. Install fork in Fork Tube Holder (HD-41177) as follows:
 - a. Clamp end of tool (1) in vise in a horizontal position.
 - b. See Figure 9. With the fork cap bolt (C) upward, clamp fork tube (T), between rubber pads on inboard side of tool. Tighten knobs until fork tube is securely held.

NOTE

Be aware that fork tube plug (D or 3) is under spring-pressure, so have a firm grasp on plug as the last thread is turned.

⚠ WARNING

Wear safety glasses or goggles when servicing fork assembly. Do not remove slider tube cap without relieving spring preload or caps and springs can fly out, which could result in death or serious injury. (00297a)

2. See Figure 9. Remove nuts (R), lockwashers (Q), flat washers (P) and axle holder (O) from studs at end of fork slider.
3. Slowly remove fork tube plug and O-ring (10) from fork tube. Discard O-ring.
4. Remove the spring (F) from the fork tube.
5. Remove fork assembly from fork tube holder. Turn fork upside down over drain pan to drain oil. For best results, slowly pump fork tube and fork slider (N) at least 10 times.
6. Install fork spring back into fork tube.
7. Put a shop rag on the floor. Turn the fork assembly upside down and press the end of the spring against the rag. Compress the spring and remove the screw (M) with copper washer (L) from the bottom end of fork slider. Use air impact wrench for best results. Discard screw and copper washer.
8. Remove fork spring. Save for later use.
9. Push the damper tube and rebound spring (S) free of fork tube by inserting a small diameter rod through the opening in the bottom of tube. Discard damper tube.



10. Remove oil lock (U) from the lower end of stock damper tube. Save oil lock for later use.
11. Using pick tool, remove retaining clip (E) between fork slider and fork tube. Do not expand or stretch retaining clip to remove from fork tube or clip may be damaged.

NOTE

To overcome any resistance, use the fork tube as a slide hammer: Push fork tube into fork slider and then pull it outward with a moderate amount of force. Repeat this sequence until fork tube separates from fork slider.

12. Remove fork tube from fork slider.
13. Slide fork oil seal (9), slider washer (G) and slider bushing (I) off end of fork tube. Discard fork oil seal.

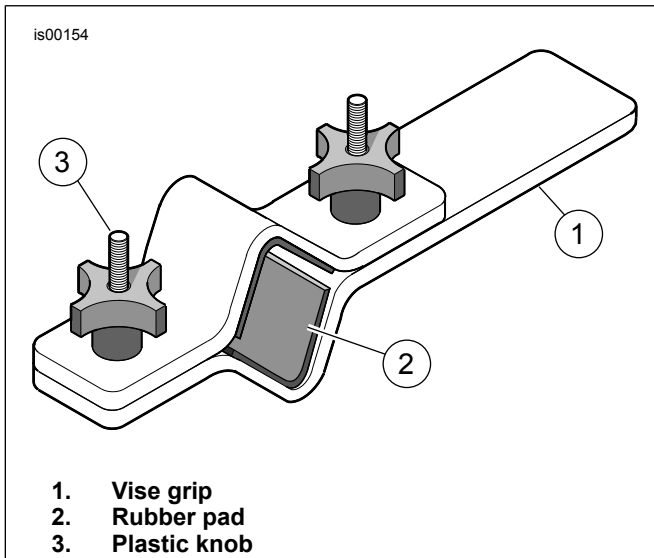

Figure 1. Fork Tube Holder (HD-41177)

Fork Assembly

NOTICE

Exercise caution to avoid scratching or nicking fork tube. Damaging tube can result in fork oil leaks after assembly. (00421b)

NOTE

Thoroughly clean and inspect each part. If inspection shows that any parts are bent, inoperative or damaged, those parts should be replaced.

1. See Figure 9. Place rebound spring (S) on **new** damper tube from kit (12). Insert damper tube into fork tube (T).
2. Insert spring (F) into fork tube, with dense section of coils toward damper tube, and push bottom of damper tube through the opening at the bottom end of the fork tube. Place oil lock (U) over end of damper tube.
3. Position fork tube and damper tube in fork slider (N). Hold the assembly in place by exerting pressure on the spring and install **new** screw (M) with copper washer (L).
4. Tighten screw to 15–25 N·m (11–18 ft-lbs).

5. Coat slider bushing (I) with clean fork oil. Slide slider bushing down fork tube (either direction).
6. Slide slider washer (G) down fork tube until it contacts slider bushing (either direction).
7. Coat the **new** fork oil seal (9) ID with clean fork oil. With the lettering side facing up, slide fork oil seal down the fork tube until it contacts the slider washer.
8. See Figure 2. Obtain the Fork Seal/Bushing Tool (HD-34634) and proceed as follows:
 - a. Slide the fork seal installer down the fork tube until it contacts the fork oil seal.
 - b. See Figure 3. Using the tool like a slide hammer, drive fork oil seal (with slider washer and slider bushing) down the fork tube until retaining clip groove is visible in fork slider ID.
 - c. Slide the retaining clip (E) down the fork tube until it contacts the fork oil seal. Install retaining clip in the fork slider groove. Do not expand or stretch retaining clip to install on fork tube or clip may be damaged.

NOTE

Install the drain screw at the bottom of the fork slider, if removed. Tighten the screw to 6–9 N·m (52–78 in-lbs).

9. Remove fork spring.

▲ WARNING

Incorrect amount of fork oil can adversely affect handling and lead to loss of vehicle control, which could result in death or serious injury. (00298a)

10. Fill fork tube as follows:
 - a. With fork tube compressed, pour Harley-Davidson Type E Fork Oil into the fork tube almost to the top.
 - b. Pump fork tube ten times to remove air from system.
11. Adjust the fork oil level, so that it is 124 mm (4.88 in) from the top of the fork tube with the fork tube compressed and the fork spring removed. Proceed as follows:
 - a. See Figure 4. Obtain the Front Fork Oil Level Gauge (HD-59000B).
 - b. Loosen thumbscrew on metal ring and move it up or down the rod until the bottom of the ring is 124 mm (4.88 in) from the bottom of the rod. Tighten thumbscrew.
 - c. Push the plunger on the cylinder all the way in.
 - d. See Figure 5. Insert rod into top of fork tube until metal ring rests flat on top of fork tube.
 - e. Pull plunger to remove fork oil from fork tube. Observe fork oil through transparent tube to verify oil is being drawn from fork.

- f. Remove rod from fork tube. Push plunger into cylinder to eject excess fork oil into suitable container.
- g. If necessary, repeat Steps 11(c) through 11(f). Level is correct when no fork oil is observed being drawn through transparent tube.

NOTE

Verify the fork spring is installed with dense section of coils to the bottom.

12. Install fork spring into the fork tube with the dense end down.
13. Install **new** O-ring (10) onto fork tube plug (D).
14. Install fork tube plug. Tighten to 81.3–95 N·m (60–70 ft-lbs).
15. Install **new** quad ring seal (13) onto fork cap bolt. Thread fork cap bolt (C) into fork tube plug to prevent loss of fork oil while handling.



Figure 2. Fork Seal/Bushing Tool (HD-34634)

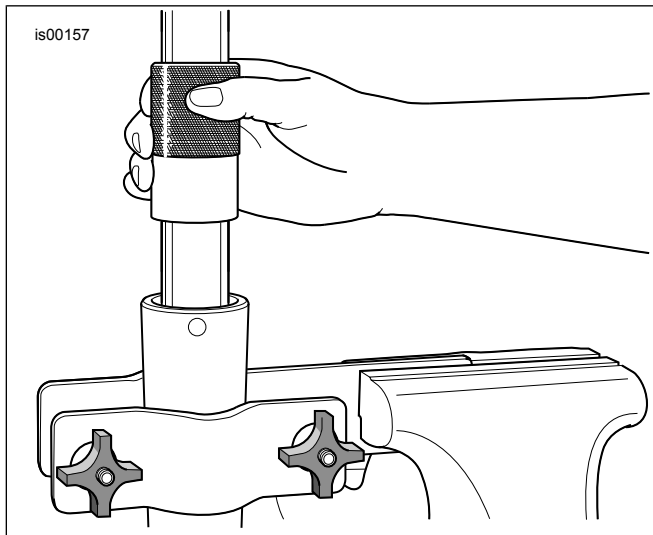

Figure 3. Install Fork Oil Seal

LEFT SIDE

Fork Disassembly

1. Obtain left fork assembly removed in earlier step.

2. See Figure 1. Install fork in Fork Tube Holder (HD-41177) as follows:

- a. Clamp end of tool (1) in vise in a horizontal position.
- b. See Figure 9. With the fork cap bolt upward, clamp fork tube (T), between rubber pads on inboard side of tool. Tighten knobs until fork tube is securely held.

NOTE

Be aware that fork tube plug (D or 3) is under spring-pressure, so have a firm grasp on plug as the last thread is turned.

▲ WARNING

Wear safety glasses or goggles when servicing fork assembly. Do not remove slider tube caps without relieving spring preload or caps and springs can fly out, which could result in death or serious injury. (00297a)

3. Slowly remove fork tube plug and O-ring (10) from fork tube. Discard O-ring.
4. Remove the fork spring (F) from the fork tube.
5. Remove fork assembly from fork tube holder. Turn fork upside down over drain pan to drain oil. For best results, slowly pump fork tube and fork slider (N) at least 10 times.
6. Install fork spring back into fork tube.
7. Put a shop rag on the floor. Turn the fork assembly upside down and press the end of the spring against the rag. Compress the spring and remove the screw (M) with copper washer (L) from the bottom end of fork slider. Use air impact wrench for best results. Discard screw and copper washer.
8. Remove and discard fork spring.
9. Push the damper tube and rebound spring (S) free of fork tube by inserting a small diameter rod through the opening in the bottom of tube. Discard damper tube, and rebound spring.
10. Remove and discard oil lock (U) from the lower end of stock damper tube.
11. Using pick tool, remove retaining clip (E) between fork slider and fork tube. Do not expand or stretch retaining clip to remove from fork tube or clip may be damaged.

NOTE

To overcome any resistance, use the fork tube as a slide hammer: Push fork tube into fork slider and then pull it outward with a moderate amount of force. Repeat this sequence until fork tube separates from fork slider.

12. Remove fork tube from fork slider.
13. Slide fork oil seal (9), slider washer (G) and slider bushing (I) off end of fork tube. Discard fork oil seal and fork tube.

Fork Assembly

NOTICE

Exercise caution to avoid scratching or nicking fork tube. Damaging tube can result in fork oil leaks after assembly. (00421b)

NOTE

Thoroughly clean and inspect each part. If inspection shows that any parts are bent, inoperative or damaged, those parts should be replaced.

1. See Figure 9, Section A. If not already installed, coat **new** fork tube bushing (11) ID with clean fork oil. Expand fork tube bushing at split line only as far as required to slip over end and into groove of fork tube (7).
2. Install fork slider (V) in fork tube holder. Slide fork tube (7) into fork slider.
3. Coat slider bushing (I) ID with clean fork oil. Slide slider bushing down fork tube (either direction).
4. Slide slider washer (G) down fork tube until it contacts slider bushing (either direction).
5. Coat the **new** fork oil seal (9) ID with clean fork oil. With the lettering side facing up, slide fork oil seal down the fork tube until it contacts the slider washer.
6. See Figure 2. Obtain the Fork Seal/Bushing Tool (HD-34634) and proceed as follows:
 - a. Slide the fork seal installer down the fork tube until it contacts the fork oil seal.
 - b. See Figure 3. Using the tool like a slide hammer, drive fork oil seal (with slider washer and slider bushing) down the fork tube until retaining clip groove is visible in fork slider ID.
 - c. Slide the retaining clip (E) down the fork tube until it contacts the fork oil seal. Install retaining clip in the fork slider groove. Do not expand or stretch retaining clip to install on fork tube or clip may be damaged.
7. Remove assembly from fork tube holder.
8. Install oil lock (8) over the end of the damper cartridge (2).
9. Hold fork assembly horizontal and slide damper cartridge with oil lock into fork assembly.
10. Push down on cartridge.
11. Install **new** screw (M) with copper washer (L). Slide screw through hole at bottom of fork slider and start into end of damper cartridge.
12. Obtain fork spring (1) from the kit. Install **new** fork spring into fork tube, with dense section of coils toward damper cartridge.

13. Put a shop rag on the floor. Turn the fork assembly upside down and press the end of the spring against the rag. Compress the spring and tighten the screw to 15–25 N·m (11–18 ft-lbs).

14. With the fork tube upright, clamp fork slider (not the fork tube) into fork tube holder.

NOTE

Install the drain screw at the bottom of the fork slider, if removed. Tighten the screw to 6–9 N·m (52–78 in-lbs).

15. Fill the fork tube as follows:

- a. See Figure 8. Thread extension tool onto end of damper rod.
- b. With the fork tube compressed, pour Harley-Davidson Type E Fork Oil into the fork tube almost to the top. Pump fork tube ten times to remove air from system.
- c. Slowly pump the damper rod until resistance is felt and then pump ten more times.
- d. Place the damper rod in the fully bottomed position.
- e. Remove the extension tool from the end of the damper rod.

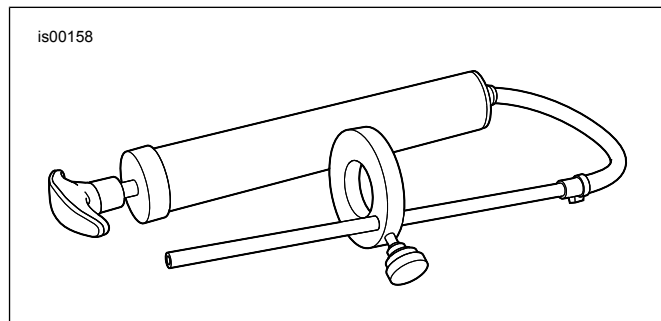

Figure 4. Front Fork Oil Level Gauge (HD-59000B)

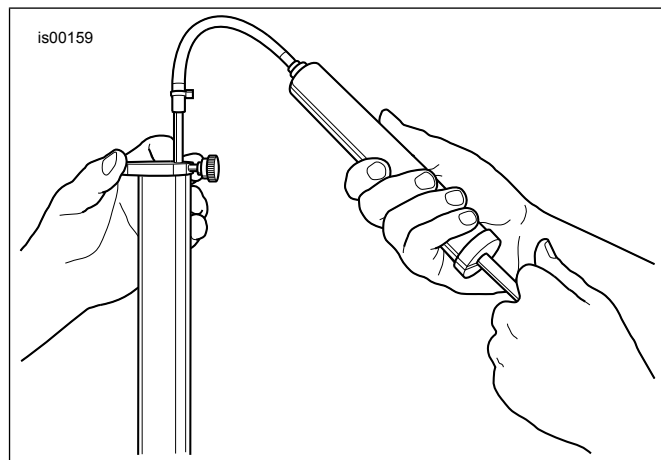

Figure 5. Remove Excess Fork Oil

⚠ WARNING

Incorrect amount of fork oil can adversely affect handling and lead to loss of vehicle control, which could result in death or serious injury. (00298a)

16. Adjust the fork oil level, so that it is 142 mm (5.59 in) from the top of the fork tube with the fork tube compressed and the fork spring removed. Proceed as follows:
- See Figure 4. Obtain the Front Fork Oil Level Gauge (HD-59000B).
 - Loosen thumbscrew on metal ring and move it up or down the rod until the bottom of the ring is 142 mm (5.59 in) from the bottom of the rod. Tighten thumbscrew.
 - Push the plunger on the cylinder all the way in.
 - See Figure 5. Insert rod into top of fork tube until metal ring rests flat on top of fork tube.
 - Pull plunger to remove fork oil from fork tube. Observe fork oil through transparent tube to verify oil is being drawn from fork.
 - Remove rod from fork tube. Push plunger into cylinder to eject excess fork oil into suitable container.
 - If necessary, repeat Steps 16(c) through 16(f). Level is correct when no fork oil is observed being drawn through transparent tube.

NOTE

Verify the fork spring is installed with dense section of coils to the bottom.

17. Install fork spring into the fork tube with the dense end down.

18. Thread extension tool onto end of damper rod.

NOTE

Do not use an air impact wrench to adjust the fork spring compression tool.

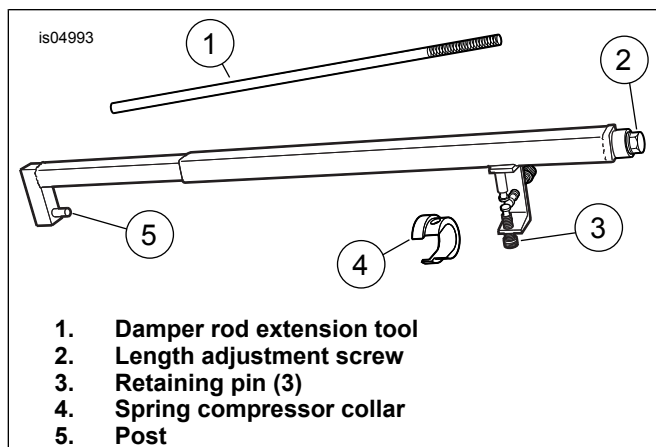

Figure 6. Fork Spring Compressing Tool (HD-45966)

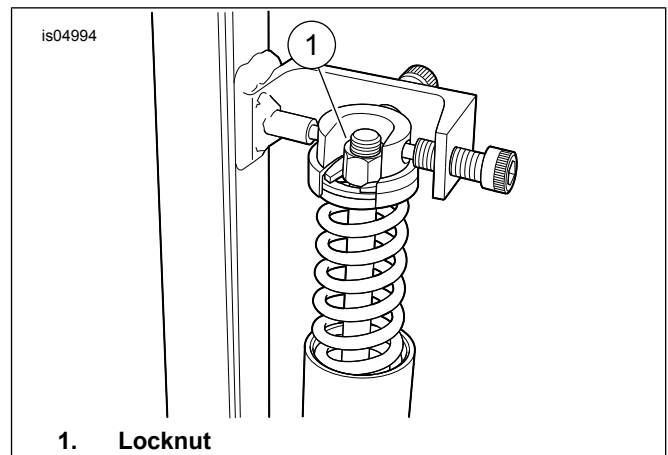

Figure 7. Compress Fork Spring

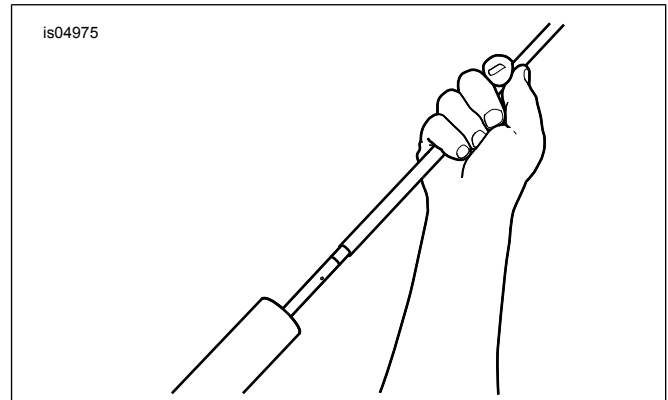

Figure 8. Pump Damper Rod Extension Tool

▲ WARNING

Wear safety glasses or goggles when removing or installing spring. Spring tension can cause spring, attached components and/or hand tools to fly out which could result in death or serious injury. (00477c)

19. See Figure 6. Install fork spring compressing tool as follows:

- Clamp tool in vise in a vertical position with length adjustment screw (2) upward.
- Place hole at bottom of fork slider over post (5) at bottom end of tool.
- Place flat washer (Item 6, Figure 9), over the damper rod extension tool and on top of spring. Place spring seat (Item 5, Figure 9), concave side up, on top of the flat washer. With the smaller OD upward, place spring compressor collar (item 4, Figure 6) over spring seat and flat washer.
- Adjust tool as necessary until three retaining pins (3) engage blind holes in spring compressor collar (4). Turn length adjustment screw counterclockwise to lengthen and clockwise to shorten.
- Turn retaining pins as necessary to lock position of spring compressor collar.
- Turn length adjustment screw in a clockwise direction to compress spring.

20. After a number of turns, pull up on extension tool to raise damper rod. If threaded portion of rod cannot be pulled completely out of spring, compress spring further. Repeat until threaded portion of rod can be pulled completely out of spring.
21. Remove extension tool, while holding the damper rod in the extended position.
22. Install **new** jam nut (4) with non-threaded end over the damper rod first. Thread onto damper rod until it bottoms out on the shoulder.
23. Turn the length adjustment screw at top end of fork spring compressing tool counterclockwise to release tension on fork spring. Loosen retaining pins and remove spring compressor. Remove fork assembly from tool and remove tool from vise.
24. Install fork tube holder in vise. Clamp fork tube into fork tube holder.
25. Install **new** O-ring (10) onto fork tube plug (3). Thread fork tube plug onto threaded end of damper rod until it bottoms. Turn jam nut counterclockwise until it makes firm contact with the fork tube plug. Tighten jam nut to 18–27 N·m (13–20 ft-lbs).

NOTE

Do NOT over-tighten or O-ring damage may occur.

26. Thread **new** fork tube plug (3) into fork tube. Tighten fork tube plug to 81–95 N·m (60–70 ft-lbs).

27. Install **new** quad ring seal (13) onto fork cap bolt. Thread fork cap bolt (C) into fork tube plug to prevent loss of fork oil while handling.

Fork Installation

1. Refer to the appropriate service manual and install the front forks.

▲ WARNING

After repairing the brake system, test brakes at low speed. If brakes are not operating properly, testing at high speeds can cause loss of control, which could result in death or serious injury. (00289a)

▲ WARNING

Whenever a wheel is installed and before moving the motorcycle, pump brakes to build brake system pressure. Insufficient pressure can adversely affect brake performance, which could result in death or serious injury. (00284a)

2. See the appropriate service manual and install front fender, wheel, brakes and any other removed parts.
3. Pump brakes to build system pressure.

Test Ride

1. Test ride motorcycle to verify fork travel and rebound.

SERVICE PARTS

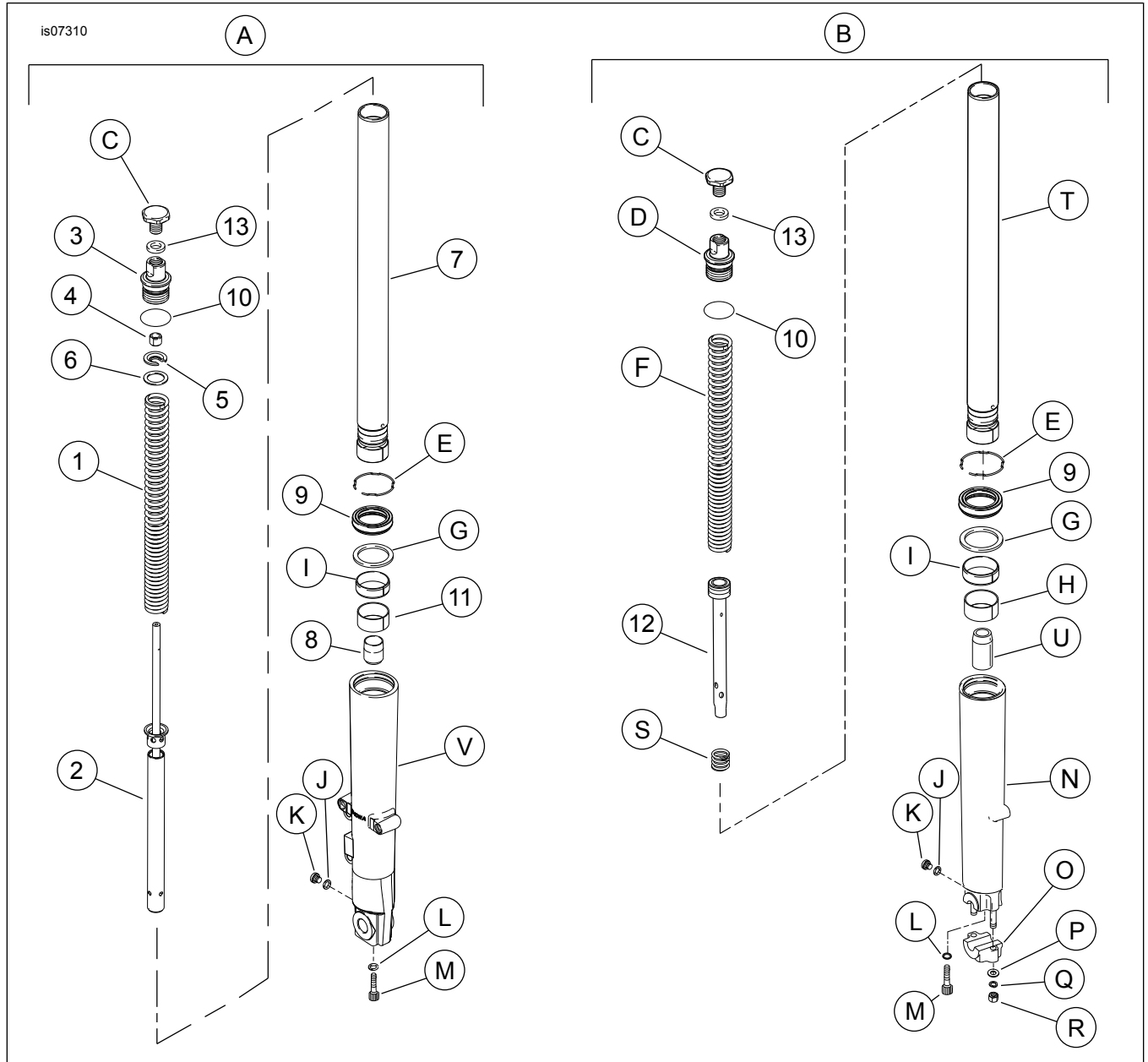

Figure 9. Service Parts: Softtail Cartridge Front Fork Kit

Table 2. Service Parts Table

Item	Description (Quantity)	Part Number
A	Cartridge Fork from Kit (left side)	
B	Stock Fork Assembly, Non-cartridge Fork from Kit (right side)	
Items included in kit:		
1	Fork spring	Not Sold Separately
2	Damper cartridge	Not Sold Separately
3	Fork tube plug	46229-02
4	Jam nut	46262-02
5	Spring seat	46236-02
6	Washer, flat	46237-02
7	Fork tube	Not Sold Separately
8	Oil lock	46238-02
9	Fork oil seal (2)	45875-84A
10	O-ring (2)	45845-77
11	Fork tube bushing	45866-84
12	Damper tube	Not Sold Separately

Table 2. Service Parts Table

Item	Description (Quantity)	Part Number
13	Quad ring seal (2)	45733-48
Items mentioned in text, but not included in kit:		
C	Fork cap bolt (2)	
D	Fork tube plug	
E	Retaining clip (2)	
F	Spring	
G	Slider washer (2)	
H	Bushing, fork tube (1)	
I	Bushing slider (2)	45940-84
J	Washer, flat (2)	
K	Plug (2)	
L	Washer, copper, crush (2)	
M	Screw, 6mm (2)	45405-75A
N	Fork slider, right	
O	Axle holder	
P	Washer, flat (2)	
Q	Lock washer (2)	
R	Nut (2)	
S	Rebound spring	
T	Fork tube	
U	Oil lock	
V	Fork slider, left	