



# INSTRUCTIONS

J05516

2012-07-12



## FLD AUXILIARY LAMP MOUNTING KIT

### GENERAL

#### Kit Number

68000051

#### Models

For model fitment information, see the P&A retail catalog or the Parts and Accessories section of [www.harley-davidson.com](http://www.harley-davidson.com) (English only).

#### Installation Requirements

**Separate purchase** of an auxiliary lamp bulb kit is required for proper installation of this kit. See the P&A retail catalog or the Parts and Accessories section of [www.harley-davidson.com](http://www.harley-davidson.com) (English only) for a list of auxiliary lamp bulb kits.

**FLSTF models** will also require an FLSTF Auxiliary Lamp Mounting and Turn Signal Relocation Hardware Kit (Part No. 68000069).

#### ⚠ WARNING

Rider and passenger safety depend upon the correct installation of this kit. Use the appropriate service manual procedures. If the procedure is not within your capabilities or you do not have the correct tools, have a Harley-Davidson dealer perform the installation. Improper installation of this kit could result in death or serious injury. (00333b)

#### NOTE

*This instruction sheet refers to service manual information. A service manual for this year/model motorcycle is required for this installation and is available from a Harley-Davidson dealer.*

### Electrical Overload

#### NOTICE

It is possible to overload the vehicle's charging system by adding too many electrical accessories. If the combined electrical accessories operating at any one time consume more electrical current than the vehicle's charging system can produce, the electrical consumption can discharge the battery and cause damage to the vehicle's electrical system. (00211d)

#### ⚠ WARNING

When installing any electrical accessory, be certain not to exceed the maximum amperage rating of the fuse or circuit breaker protecting the affected circuit being modified. Exceeding the maximum amperage can lead to electrical failures, which could result in death or serious injury. (00310a)

The auxiliary lamps require up to **4.56 amps** additional current from the electrical system.

#### Kit Contents

See Figure 2 and Table 1.

### PREPARATION

#### NOTE

**For vehicles equipped with security siren:** Verify that the Hands-Free Fob is present. Turn the ignition key switch to **IGNITION**.

#### ⚠ WARNING

**To prevent accidental vehicle start-up, which could cause death or serious injury, remove main fuse before proceeding. (00251b)**

1. See the service manual and remove the main fuse.
2. Turn the ignition key switch OFF if not already done.

### INSTALLATION

#### Auxiliary Lamp Assembly

1. See Figure 2. Get an auxiliary lamp bulb kit (A, purchased separately) and Items 1-11 from **this** kit:
2. See Figure 1. Install an auxiliary lamp bulb (2) into an auxiliary lamp housing (3) per the instructions in the auxiliary lamp bulb kit.



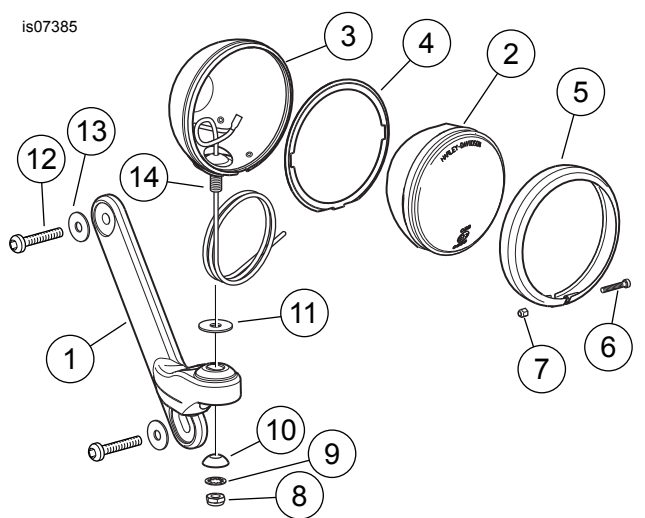

1. Auxiliary lamp mounting bar (right side shown)
2. Auxiliary lamp bulb
3. Auxiliary lamp housing
4. Nest ring
5. Bezel ring
6. Screw
7. Hex nut
8. Locknut
9. Internal tooth lockwasher
10. Clamp block
11. Rubber isolator
12. TORX button head screw (2)
13. Chrome flat washer (2)
14. Lamp housing threaded stud

Figure 1. Auxiliary Lamp Assembly

3. Secure the lamp with a nest ring (4) and bezel ring (5). Secure the bezel ring with a stainless steel machine screw (6) and hex nut (7).
4. Install a rubber isolator (11) over the lamp wire and onto the threaded stud (14) of the auxiliary lamp housing.
5. Insert the wire and stud through the hole in the mounting bar (1).
6. Install a clamp block (10), rounded side first, over the lamp wire and onto the threaded stud. Follow with an internal tooth lockwasher (9), and fasten with a locknut (8). Tighten securely.
7. Repeat with the remaining lamp and mounting bar.

## Mounting Bar Installation

1. See the service manual and remove the windshield.
2. See Figure 2. Get four chrome TORX button head screws (12) and four chrome flat washers (13) from the kit, and the auxiliary lamps and brackets assembled earlier.
3. **On one side of the vehicle**, remove the 31.8 mm (1.25 in) long windshield docking screw, washer, bushing and spacer from the upper and lower nacelle. The screws and washers can be recycled or properly disposed of.

4. Place a **new** chrome washer (13) onto the threads of a **new** chrome screw (12). Insert the screw through the upper hole of the mounting bar, the OE bushing and spacer. Loosely install the screw through the upper nacelle and into the upper fork clamp (triple tree). Use a second chrome screw and washer to fasten the mounting bar, bushing and spacer to the lower fork clamp.
5. Repeat step 4 on the opposite side of the vehicle. Alternately tighten the four screws to 9.5–13.5 N·m (84–120 in-lbs).

## Front Turn Signal Relocation (Optional)

1. Remove the seat. Retain the seat and all mounting hardware.
2. Remove the front turn signal lamps and wires from the vehicle per the service manual with the following exceptions:
  - a. Make note of the wire locations in the two three-way Multilock socket housings [31LB] and [31RB] before de-pinning.
  - b. There is no need to attach a chase wire to the harness.
3. Remove one turn signal lamp from the mounting bracket. The ball stud, set screw and jam nut can be recycled or properly disposed of.
4. Hold the mirror in place while removing the acorn nut and lockwasher. Remove the turn signal mounting bracket from the vehicle. Install the lockwasher onto the mirror threads, and fasten with the **new**, longer acorn nut from the kit. Tighten the acorn nut to 9.5–17.6 N·m (84–156 in-lbs). Recycle or properly dispose of the turn signal mounting bracket and original equipment (OE) acorn nut.
5. Repeat Steps 3-4 on the opposite side of the vehicle.
6. See Figure 2. Get two hex socket button head screws (14), helical spring lockwashers (15) and spacers (16) from the kit.
7. Install a lockwasher onto the screw threads. Insert the screw, from the top, into one of the auxiliary lamp mounting bars. Install a spacer onto the screw threads beneath the mounting bar, and thread the screw into the turn signal housing. Align the turn signal lamp to face straight forward, and tighten to 8.1–9.5 N·m (72–84 in-lbs). Repeat with the remaining turn signal lamp on the opposite side of the vehicle.

## WIRE ROUTING AND ELECTRICAL CONNECTION

1. Route the turn signal wires under the auxiliary lamp mounting bars and through the hole in the back side of the nacelle into the steering head area. Fasten the turn signal wires to the chase wire, and draw the wires back to the passage in the frame. Install the wires and terminals into the correct cavities of the socket housings, and reconnect to pin housings [31LA] and [31RA].

2. Slide a piece of conduit (17) over each of the auxiliary lamp wires. Follow service manual instructions to install a socket terminal (18) onto the end of each wire.
3. Route the wires around the outboard side of the fork slider covers and into the rear opening of the nacelle. Insert the wires into the cavities of the two-way socket housing (19) from the kit.
4. Plug socket housing (19) into the two-way pin housing of the auxiliary lamp wire harness (20).
5. Connect the insulated spade blade terminal of the auxiliary lamp wire harness to the blue/black wire terminal on the headlamp jumper harness.
6. Remove the clutch hand lever bracket upper clamp screw. If the upper screw is occupied, the lower screw can be used.
7. Get the pushbutton switch assembly (21) from the kit. Position the switch to the clamp, and align the holes.
8. Fasten the switch to the bracket with the screw, and tighten to 8–12 N·m (72–108 **in-lbs**).
9. Route the pushbutton switch wire conduit down the handlebar and into the rear opening of the nacelle. Plug the two-way socket housing of the auxiliary lamp wire harness (20) into the two-way pin housing of the pushbutton switch assembly inside the nacelle.
10. Fasten the pushbutton switch wire conduit to the handlebar with cable straps (24) from the kit.
11. Use additional cable straps to bind the turn signal wires, auxiliary lamp wires and pushbutton switch wires to other harnesses inside the nacelle.

#### **▲ WARNING**

**Be sure that steering is smooth and free without interference. Interference with steering could result in loss of vehicle control and death or serious injury. (00371a)**

12. **HDI models:** Affix the lamp switch label to the face of the clutch lever clamp.

## **RETURN TO SERVICE**

### *NOTE*

*Verify that the ignition key switch is in the OFF position **before** installing the main fuse.*

1. See the service manual and install the main fuse.
2. Test the operation of the auxiliary lamps (and turn signals if relocated).
  - Turn the ignition key switch to IGNITION, but do not start the motorcycle. The low beam headlamp should turn ON.
  - Operate the auxiliary lamp button on the brake hand lever bracket clamp ON and OFF. The auxiliary lamps should turn ON and OFF with switch operation. Test the left and right turn signals for proper operation.
  - Toggle the headlamp dimmer switch on the left handlebar control to HI to activate the high beam. Operate the auxiliary lamp switch on the brake hand lever bracket clamp ON and OFF. The auxiliary lamps should turn ON and OFF with switch operation.
  - Turn the ignition key switch to ACCESSORY. The headlamp should turn OFF. Operate the auxiliary lamp switch on the brake hand lever bracket clamp ON and OFF. The auxiliary lamps should turn ON and OFF with switch operation.
  - Turn the ignition key switch to OFF. Operate the auxiliary lamp switch on the brake hand lever bracket clamp ON and OFF. The auxiliary lamps should not illuminate. Test the left and right turn signals. They should not illuminate.

#### **▲ WARNING**

**After installing seat, pull upward on seat to be sure it is locked in position. While riding, a loose seat can shift causing loss of control, which could result in death or serious injury. (00070b)**

3. If removed, see the service manual to install the seat. Install the side cover.

## SERVICE PARTS

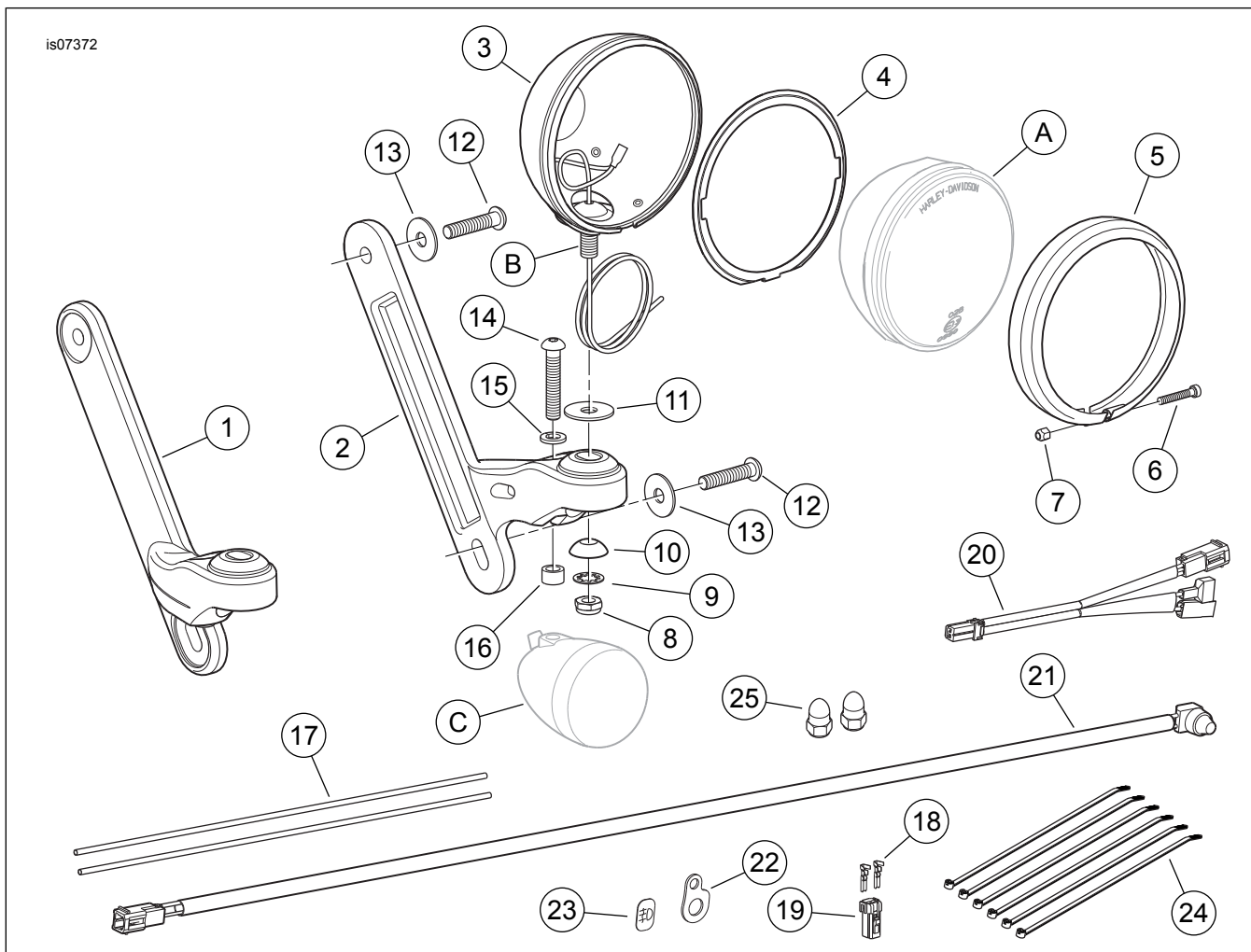

Figure 2. Service Parts, FLD Auxiliary Lamp Mounting Kit

## SERVICE PARTS

Table 1. Service Parts

Item	Description (Quantity)	Part Number
1	Mounting bar, auxiliary lamp (right)	Not sold separately
2	Mounting bar, auxiliary lamp (left)	Not sold separately
3	Housing, auxiliary lamp, chrome (2)	68822-04
4	Nest ring, auxiliary lamp (2)	68331-02
5	Bezel ring, auxiliary lamp (2)	68725-62A
6	Machine screw, #8-32 x 25.4 mm (1.0 in), fillister head, stainless steel (2)	3514
7	Hex nut, #8-32, stainless steel (2)	7606
8	Hex nut, 3/8-16, thin, with nylon insert	7667
9	Lockwasher, 3/8 in, internal tooth (2)	7130W
10	Clamp block, auxiliary lamp (2)	69563-06
11	Isolator, rubber (2)	40901-05
12	Screw, button head TORX, 5/16-18 x 38.1 mm (1.5 in) long, chrome (4)	4784
13	Flat washer, 25.4 mm (1.0 in) long, chrome (4)	6373
14	Screw, hex socket button head (2)	4343
15	Lockwasher, helical spring, 5/16 in (2)	7041
16	Spacer (2)	Not sold separately
17	Conduit, 30.5 cm (12 in) (2)	Not sold separately
18	Socket terminal (2)	73191-96
19	Socket housing, two-way	73152-96BK
20	Wire harness, auxiliary lamp	Not sold separately
21	Push button switch and harness assembly	Not sold separately
22	Bracket, switch mounting	70371-00

**Table 1. Service Parts**

<b>Item</b>	<b>Description (Quantity)</b>	<b>Part Number</b>
23	Label, lamp switch (HDI)	Not sold separately
24	Cable strap (6)	10181
25	Acorn nut (2)	7720
<b>Items mentioned in text, but not included in kit:</b>		
A	Four in (102 mm) sealed beam or LED lamp (2) from Auxiliary Lamp Bulb Kit	
B	Threaded stud of auxiliary lamp housing	
C	OE front turn signal lamp (2)	