



INSTRUCTIONS

J05663

2013-05-01



CHROME SPORTSTER SWINGARM

GENERAL

Kit Number

48434-05A

Models

For model fitment information, see the P&A Retail Catalog or the Parts and Accessories section of www.harley-davidson.com (English only).

⚠ WARNING

Rider and passenger safety depend upon the correct installation of this kit. Use the appropriate service manual procedures. If the procedure is not within your capabilities or you do not have the correct tools, have a Harley-Davidson dealer perform the installation. Improper installation of this kit could result in death or serious injury. (00333b)

NOTE

This instruction sheet references Service Manual information. A Service Manual for your model motorcycle is required for this installation and is available from a Harley-Davidson dealer.

Kit Contents

See Figure 1 and Table 1.

Table 1. Service Parts

Item	Description (Quantity)	Part Number
1	Swingarm, chrome	Not Sold Separately
2	Label, battery warning	15368-01A

INSTALLATION

1. Remove stock rear fork (swingarm). Refer to REAR FORK, REMOVAL, in Service Manual.
2. Remove bearings from existing swingarm and install in chrome swingarm (1). Refer to REAR FORK, DISASSEMBLY and ASSEMBLY in Service Manual.
3. Apply battery warning label (2) to swingarm at location (A).
4. Install new swingarm assembly. Refer to REAR FORK, INSTALLATION in Service Manual.

SERVICE PARTS

See Figure 1 and Table 1.

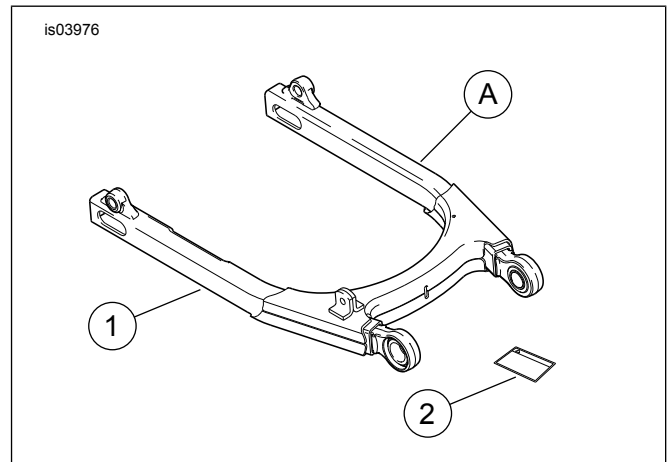

Figure 1. CHROME SWINGARM KIT