



INSTRUCTIONS

J06126

2015-03-10



RED FRONT BRAKE CALIPER KIT

GENERAL

Kit Numbers

41300152

Models

For model fitment information, see the P&A retail catalog or the Parts and Accessories section of www.harley-davidson.com (English only).

This kit is a direct replacement for the original equipment (OE) component, and installs in the same manner.

Installation Requirements

Fresh, uncontaminated hydraulic brake fluid from a sealed container is needed. Refer to the service manual for this year/model motorcycle to determine the correct brake fluid.

⚠ WARNING

Rider and passenger safety depend upon the correct installation of this kit. Use the appropriate service manual procedures. If the procedure is not within your capabilities or you do not have the correct tools, have a Harley-Davidson dealer perform the installation. Improper installation of this kit could result in death or serious injury. (00333b)

NOTE

This instruction sheet refers to service manual information. A service manual for this year/model motorcycle is required for this installation. One is available from a Harley-Davidson dealer.

⚠ WARNING

Brakes are a critical safety component. Contact a Harley-Davidson dealer for brake repair or replacement. Improperly serviced brakes can adversely affect brake performance, which could result in death or serious injury. (00054a)

Kit Contents

See Figure 1 and Table 1.

PREPARATION

⚠ WARNING

To prevent accidental vehicle start-up, which could cause death or serious injury, remove main fuse before proceeding. (00251b)

NOTE

- **WITH security siren:** With security fob present, turn ignition switch ON. See the service manual. Disarm security system. Turn ignition switch OFF. **IMMEDIATELY** remove the main fuse.
- **WITHOUT security siren:** See the service manual. Remove main fuse .

INSTALLATION

⚠ WARNING

Contact with DOT 4 brake fluid can have serious health effects. Failure to wear proper skin and eye protection could result in death or serious injury.

- **If inhaled:** Keep calm, remove to fresh air, seek medical attention.
- **If on skin:** Remove contaminated clothing. Rinse skin immediately with plenty of water for 15-20 minutes. If irritation develops, seek medical attention.
- **If in eyes:** Wash affected eyes for at least 15 minutes under running water with eye lids held open. If irritation develops, seek medical attention.
- **If swallowed:** Rinse mouth and then drink plenty of water. Do not induce vomiting. Contact Poison Control. Immediate medical attention required.
- See Safety Data Sheet (SDS) for more details available at sds.harley-davidson.com

(00240e)

NOTICE

DOT 4 brake fluid will damage painted and body panel surfaces it comes in contact with. Always use caution and protect surfaces from spills whenever brake work is performed. Failure to comply can result in cosmetic damage. (00239c)

NOTE

If DOT 4 brake fluid contacts painted surfaces, IMMEDIATELY flush area with clear water.

Cover nearby motorcycle surfaces to protect against damage to the finish caused by spillage or splash of DOT 4 brake fluid.

⚠ WARNING

Replace brake line gaskets. Re-using original gaskets can cause brake failure and loss of vehicle control, which could result in death or serious injury. (00318a)

NOTICE

Remove brake line components carefully. Damage to seating surfaces can cause leakage. (00320a)



1. See the service manual. Remove the front brake caliper.
2. Install **new** front brake caliper per the service manual.

COMPLETION

NOTE

Verify that ignition switch is **OFF** **before** installing main fuse.

1. See the service manual. Install main fuse.

⚠ WARNING

After servicing brakes and before moving motorcycle, pump brakes to build brake system pressure. Insufficient pressure can adversely affect brake performance, which could result in death or serious injury. (00279a)

SERVICE PARTS

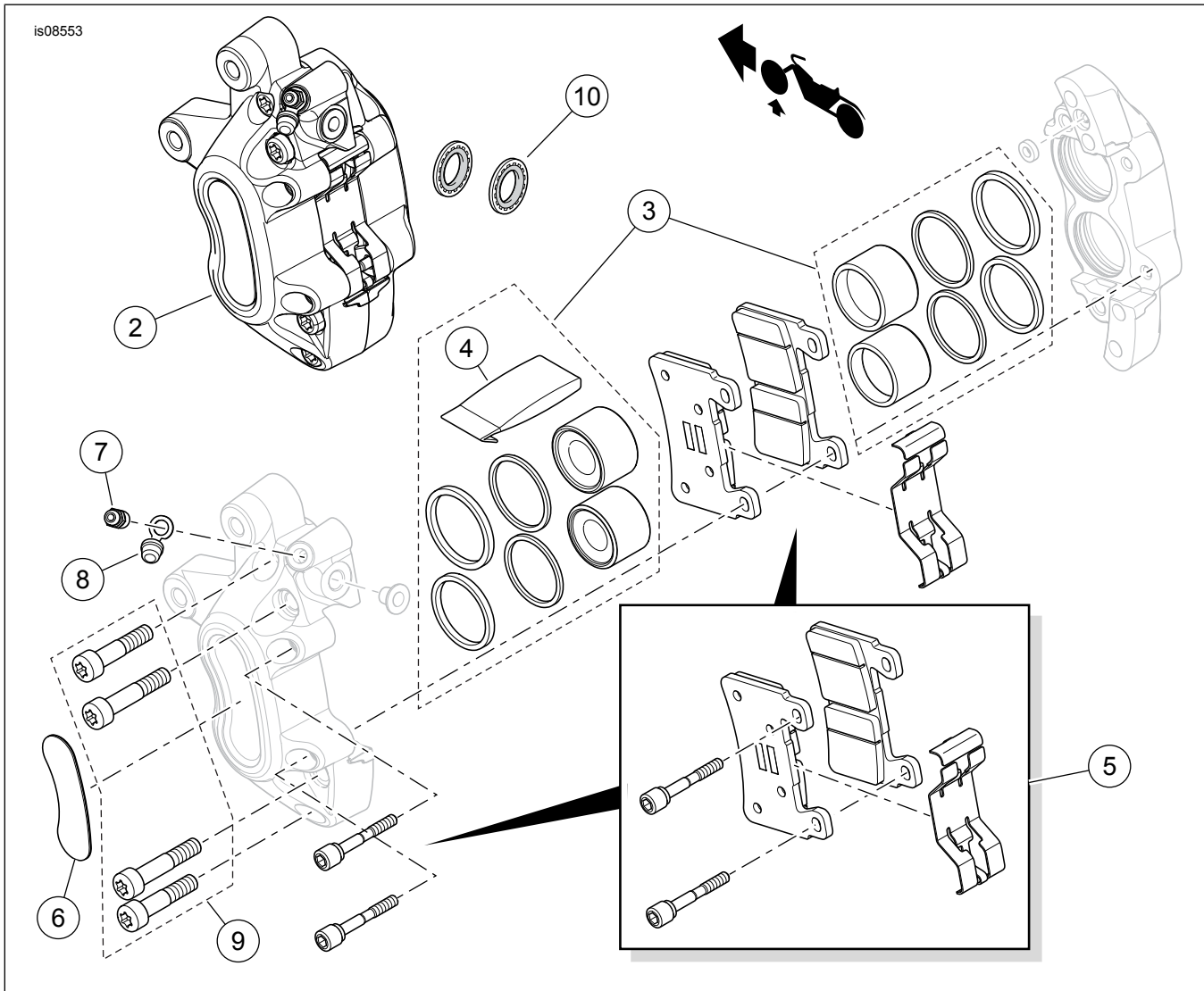

Figure 1. Service Parts, Brake Caliper Kit

Table 1. Service Parts

| Item | Description (Quantity) | Part Number |
|------|--|---------------------|
| 1 | Brake caliper kit, front (Red) | 41300152 |
| 2 | • Brake caliper assembly, front (Red). Includes Items 3-9. | Not sold separately |
| 3 | • ... Piston kit (includes Item 4) | 41300103 |

⚠ WARNING

After repairing the brake system, test brakes at low speed. If brakes are not operating properly, testing at high speeds can cause loss of control, which could result in death or serious injury. (00289a)

Table 1. Service Parts

| Item | Description (Quantity) | Part Number |
|-------------|---|--------------------|
| 4 | • ... Brake grease, G40M (2 grams) | 42820-04 |
| 5 | • ... Pad kit, front brake | 41300102 |
| 6 | • ... Decal, "HARLEY-DAVIDSON" | 14100606 |
| 7 | • ... Bleeder screw | 42827-04 |
| 8 | • ... Cap, bleeder | 42828-04 |
| 9 | • ... Bolt kit, front brake caliper (Black) | 41300104 |
| 10 | • Brake line gasket (2) | 41756-08 |