



INSTRUCTIONS

J05757

2013-06-17



TOUR-PAK SMOKED WRAP-AROUND LED LIGHT KIT

GENERAL

Kit Numbers

67800368

Models

For model fitment information, see the P&A retail catalog or the Parts and Accessories section of www.harley-davidson.com (English only).

Tools and Supplies Required

⚠ WARNING

Rider and passenger safety depend upon the correct installation of this kit. Use the appropriate service manual procedures. If the procedure is not within your capabilities or you do not have the correct tools, have a Harley-Davidson dealer perform the installation. Improper installation of this kit could result in death or serious injury. (00333b)

NOTE

This instruction sheet refers to service manual information. A service manual for this year/model motorcycle is required for this installation and is available from a Harley-Davidson dealer.

Kit Contents

See Figure 2 and Table 1.

INSTALLATION

Preparation

⚠ WARNING

To prevent accidental vehicle start-up, which could cause death or serious injury, remove main fuse before proceeding. (00251b)

- Remove the main fuse. Refer to the service manual.
- Remove Tour-Pak liner:
 - Support Tour-Pak lid partly open.
 - Remove two screws securing lid tether anchor to Tour-Pak bottom.
 - Remove liner.
 - Loosely install tether anchor to support the lid during installation.
- Remove both antenna masts from lamp housing. Set aside.
- See Figure 1. Disconnect AM/FM radio antenna cable connector (3).
- Disconnect electrical connector (4).

- Remove nut (5), washer and ring terminal from CB antenna stud. Retain for assembly.
- Remove nut (2), ring terminal and large flat washer from AM/FM radio antenna stud. Retain for assembly.
- Remove eight screws (1) to free lamp assembly from Tour-Pak.

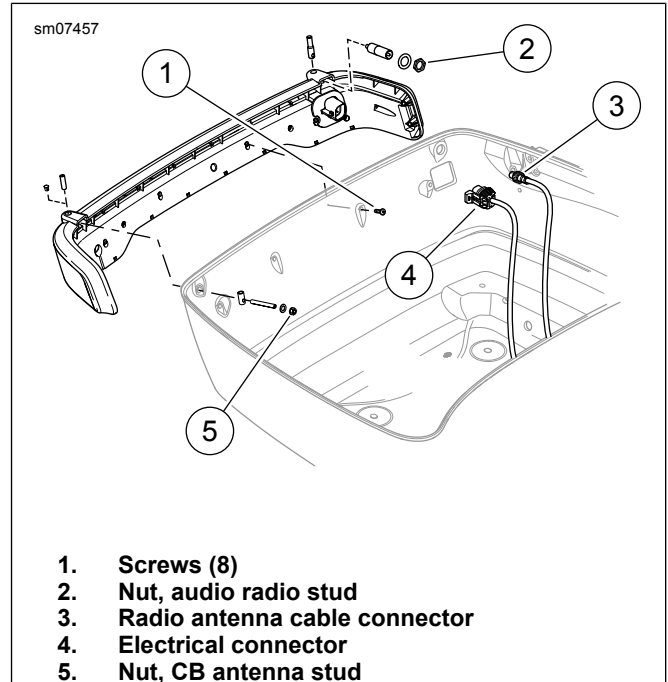

Figure 1. Wrap-around Lamp

Installation

- See Figure 1. Install lamp and secure with eight screws (1). Tighten to 2.3–2.8 N·m (20–25 in-lbs).
- Install electrical connector (4).
- Install large flat washer, ring terminal and nut (2) onto AM/FM radio antenna stud. Tighten to 1.8–2.1 N·m (16–19 in-lbs).
- Connect AM/FM radio antenna cable connector (3).
- Install ring terminal, flat washer and nut (5) onto CB antenna stud. Tighten to 1.6–1.8 N·m (14–16 in-lbs). Connect CB antenna cable if equipped.
- See Figure 2. Transfer stud (A) or plug (B) from the original lamp assembly.
- Install both antenna masts.

NOTE

Verify that the ignition key switch is in the OFF position before installing the main fuse.

- 8. Install the main fuse. Refer to the service manual.
- 9. Check the AM/FM and CB radio for proper operation.

Check Lamp Function

Check for proper lamp function:

- With ignition key switch ON, All three lamp sections are illuminated.

- With brake lever or brake pedal actuation, the CENTER section will brighten.
- With left or right turn signal actuation, the end sections will flash.

- 1. Install Tour-Pak liner:
 - a. Support Tour-Pak lid partly open.
 - b. Remove tether anchor.
 - c. Install liner.
 - d. Secure tether anchor with two screws. Tighten to 2.8–3.9 N·m (25–35 in-lbs).

SERVICE PARTS

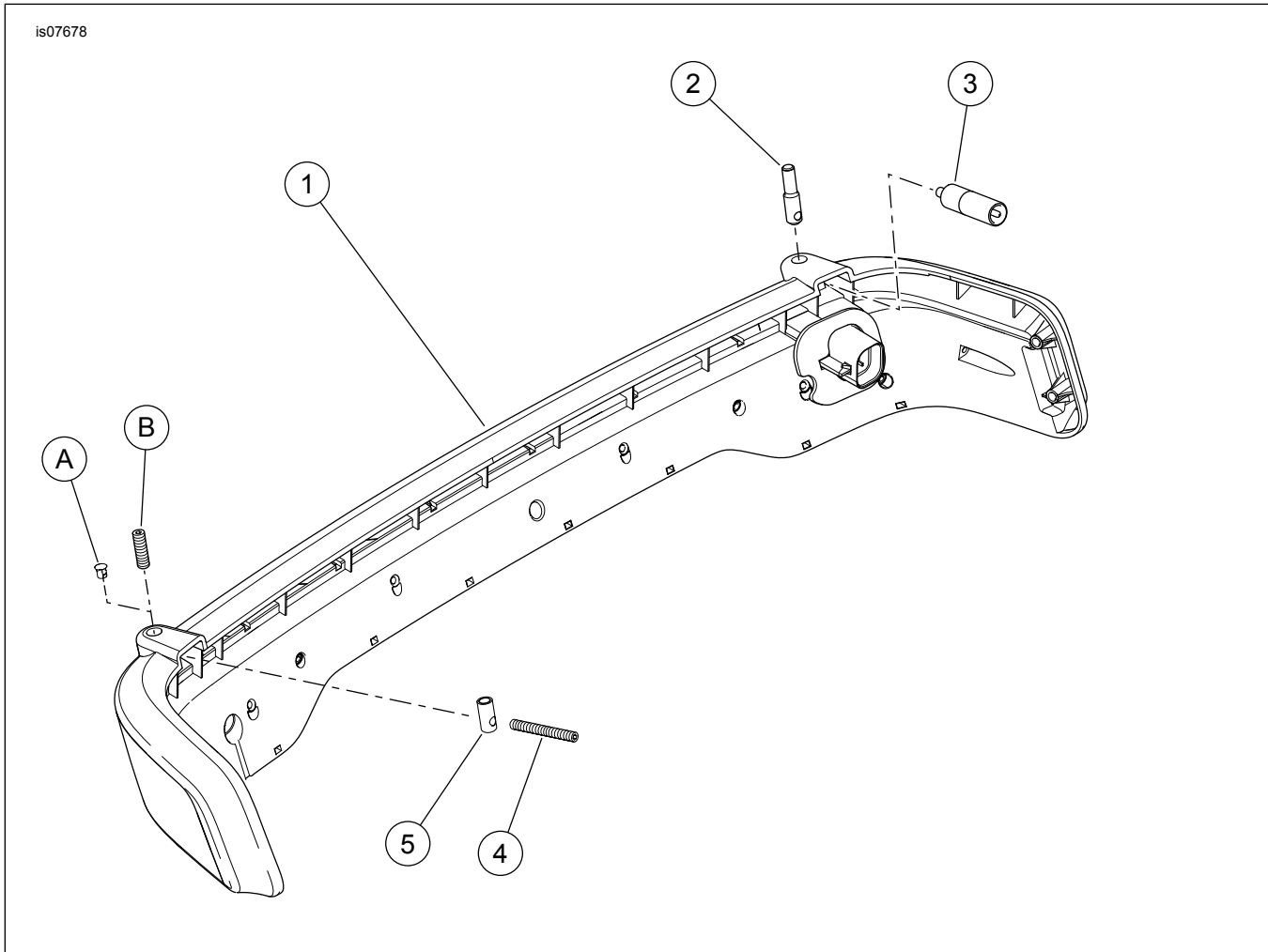

Figure 2. Service Parts, Tour-Pak Smoked Wrap-Around Light Kit

SERVICE PARTS

Table 1. Service Parts Table

Kit	Item	Description (Quantity)	Part Number
Part No. 67800368 SMOKED LED WRAP-AROUND LAMP KIT	1	LED Wrap-Around Lamp assembly (includes items 2 through 5)	Not sold separately
	2	• Stud, AM/FM antenna	76000186
	3	• Plug assembly, antenna	76000208
	4	• Set screw, CB antenna cable	76000165
	5	• Stud adapter, CB antenna	76000164
Items mentioned in text, but not included in kit:			
	A	Plug (models without CB)	
	B	Threaded stud, CB antenna	