



INSTRUCTIONS

J06142

2014-11-18



VINTAGE WHITE FOOTPEGS WITH WEAR PEGS

GENERAL

Kit Number

50500421

Models

For model fitment information, see the P&A Retail Catalog or the Parts and Accessories section of www.harley-davidson.com (English only).

Kit Contents

See Figure 2 and Table 1.

INSTALLATION

1. Remove the hardware fastening the stock footpeg to the motorcycle footpeg support. Save the hardware for installation of new footpegs.
2. Remove the existing footpegs and spring washers. Note the orientation of the spring washers, and save for installation.
3. Remove the existing wear pegs and save for installation.

NOTE

See Figure 1. When installing the footpeg mount onto the motorcycle footpeg support (3), make sure the spring washer (1) is positioned inside of the footpeg support with the straight edge (2) toward the inside of the footpeg support.

4. Install the new footpeg mount in reverse order of stock footpeg mount removal. Place a spring washer and footpeg mount, inside the slots of the footpeg supports.

⚠ WARNING

Footrests must fold up and toward rear of motorcycle if struck. Failure to set footrests to fold up and back could result in death or serious injury. (00366a)

5. Secure each footpeg support assembly and spring washer with the screw and locknut removed earlier. Tighten the locknuts to 26 N·m (19 ft-lbs).

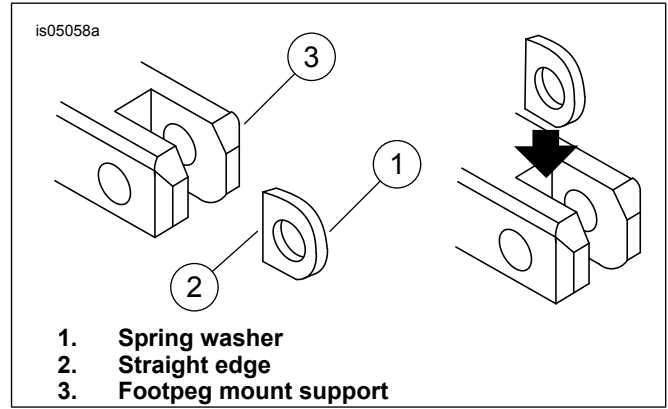

Figure 1. Vintage White Footpeg Spring Washer Installation

In Use

If your white footpegs become discolored, the use of a clean white cloth and common dish soap or Harley-Davidson Wheel and Tire Cleaner (Part No. 93600024) to clean the footpegs will aid in removing any discoloration or stains. Rinse with clean water and dry thoroughly.

Service Parts

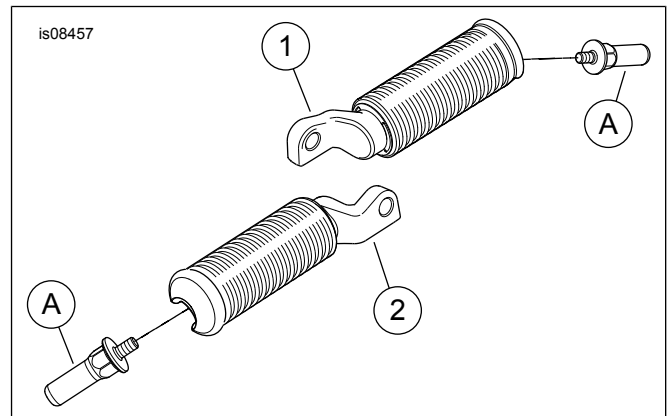

Figure 2. Service Parts: Vintage White Footpegs with Wear Pegs

Table 1. Service Parts

Item	Description (Quantity)	Part Number
1	Footpeg assembly, left	Not Sold Separately
2	Footpeg assembly, right	Not Sold Separately
Item referenced in text but not included in kit:		
A	Wear peg	