



INSTRUCTIONS

J05607

2012-07-20



FLSTF AUXILIARY LAMP MOUNTING AND FRONT TURN SIGNAL RELOCATION HARDWARE KIT

GENERAL

Kit Number

68000069

Models

This kit allows the installation of an auxiliary lamp bulb kit and an FLD Auxiliary Lamp Mounting Kit (Part No. 68000051, purchased separately) to 2000 and later FLSTF (Fat Boy[®]) model motorcycles.

See the P&A retail catalog or the Parts and Accessories section of www.harley-davidson.com (English only) for a list of auxiliary lamp bulb kits.

This kit is not compatible with certain windshields, or with the Chrome Freight Train Headlight Nacelle Kit (Part No. 67907-96C) on FLSTF models.

See the P&A retail catalog or the Parts and Accessories section of www.harley-davidson.com (English only) for windshield compatibility.

Installation Requirements

A Terminal Pick (Snap-On[®] TT600-3 or equivalent) and Amp Multi-Lock Crimper (HD-41609) will aid in the installation of this kit.

An UltraTorch UT-100 (Part No. HD-39969), Robinair Heat Gun (Part No. HD-25070) with Heatshrink Attachment (Part No. HD-41183), or other suitable radiant heating device is required for the proper installation of this kit.

Electrical Contact Lube (Part No. 99861-02) or equivalent is required after battery cable disconnection. This item is available from a Harley-Davidson dealer.

▲ WARNING

Rider and passenger safety depend upon the correct installation of this kit. Use the appropriate service manual procedures. If the procedure is not within your capabilities or you do not have the correct tools, have a Harley-Davidson dealer perform the installation. Improper installation of this kit could result in death or serious injury. (00333b)

NOTE

This instruction sheet refers to service manual information. A service manual for this year/model motorcycle is required for this installation and is available from a Harley-Davidson dealer.

Kit Contents

See Figure 4 and Table 1.

PREPARATION

NOTE

For vehicles equipped with security siren:

- **2007 and later:** Verify that the Hands-Free Fob is present. Turn the ignition key switch to IGNITION.
- **2006 and earlier:** Disarm the siren with the key fob.

For Vehicles With Main Fuse:

▲ WARNING

To prevent accidental vehicle start-up, which could cause death or serious injury, remove main fuse before proceeding. (00251b)

1. See the service manual and remove the main fuse. Remove the seat. Retain the seat and all mounting hardware.

For Vehicles With Main Circuit Breaker:

▲ WARNING

To prevent accidental vehicle start-up, which could cause death or serious injury, disconnect negative (-) battery cable before proceeding. (00048a)

1. See the service manual to remove the seat and disconnect the negative (black) battery cable from the negative (-) battery terminal. Retain all seat mounting hardware.
2. Turn the ignition key switch OFF if not already done.

INSTALLATION

Auxiliary Lamp Assembly

Assemble the auxiliary lamps to the lamp mounting bars per the instructions in the FLD Auxiliary Lamp Mounting Kit.

Mounting Bar Installation

NOTE

If there is a currently installed H-D accessory windshield or one is first being installed at the same time as these lights, the bushings and washers from THAT windshield are the same as those in THIS kit. Harley-Davidson recommends using the newer components.

1. Remove the currently installed windshield, if equipped.
2. On one side of the upper and lower fork brackets, remove and recycle or properly dispose of the screws securing the trim strip to the front and rear panel.



- See Figure 4. Get a mushroom head mounting pin (1), a hex head cap screw (2), two plain washers (3) and two bushings (4) from **this** kit, two chrome washers (A) from the FLD Auxiliary Lamp Mounting Kit, and the correct-side auxiliary lamp and mounting bar assembled earlier.
- See Figure 1. Install a chrome FLD kit washer (5) onto the mushroom pin (1) threads, then insert the threads through the upper hole of the lamp mounting bar (6).

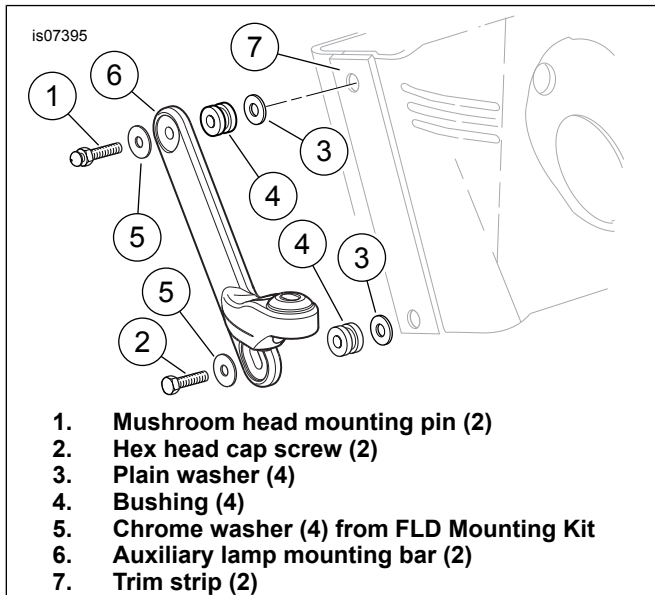

Figure 1. Auxiliary Lamp Bracket Installation (FLSTF)

- Install first a bushing (4), then a plain washer (3) onto the mushroom pin threads. Insert the threads through the upper hole of the trim strip (7), and front and rear panels. Loosely thread the pin into the upper fork bracket, but do not fully tighten at this time.
- Install a chrome FLD kit washer onto the screw (2) threads, then insert the threads through the lower hole of the lamp mounting bar, a bushing (4), plain washer (3), the trim strip (7) and front and rear panels. Thread the screw into the lower fork bracket. Tighten the upper and lower fasteners to 9.5–13.5 N·m (84–120 **in-lbs**).

Front Turn Signal Relocation (2010 and Earlier)

- Remove the front turn signal lamps and wires from the vehicle per the service manual, making note of the wire locations in the six-way Multilock socket housing [31B] before de-pinning. The ball studs, clamps, jam nuts, retainer and washer can be recycled or properly disposed of.
- Hold the mirrors in place while removing the acorn nuts and lockwashers. Remove the turn signal mounting brackets from the vehicle. Install the lockwashers onto the mirror threads, and fasten with the **new**, longer acorn nuts from the FLD Auxiliary Lamp Mounting Kit. Tighten the acorn nuts to 9.5–17.6 N·m (84–156 **in-lbs**) Recycle or properly dispose of the turn signal mounting brackets and original equipment (OE) acorn nuts.

- Install the front turn signal lamps to the auxiliary lamp mounting bars per the instructions in the FLD Auxiliary Lamp Mounting Kit.
- Route the turn signal wires back to the connector location. Install the wires and terminals into the correct cavities of the socket housing per the service manual, and reconnect to pin housing [31A].

Front Turn Signal Relocation (2011 and Later)

- See Figure 2. On one side of the vehicle, cut the turn signal wires and conduit leading to the turn signal assembly flush with the grommet (1) on the underside of the handlebar lower switch housing (2). Leave approximately 50–75 mm (2–3 in) of wire on the turn signal housing.

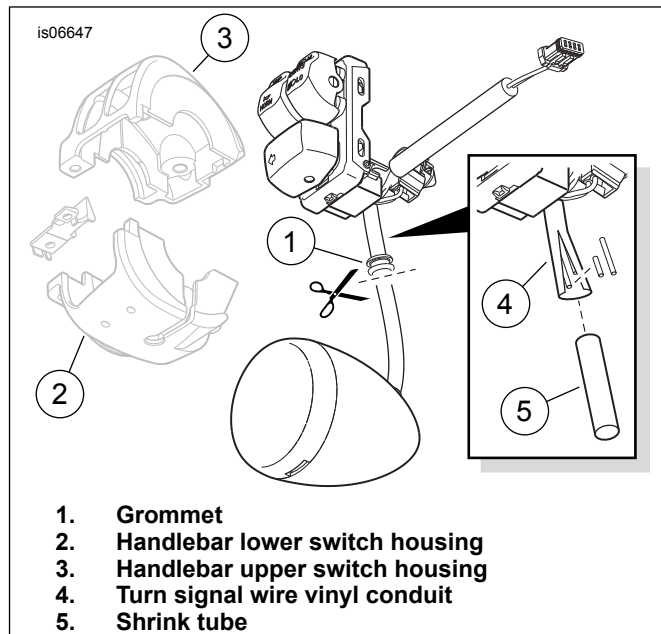

Figure 2. Cut Turn Signal From Switch Assembly

- Separate the upper (3) and lower (2) switch housings per service manual instructions.
- Remove the grommet (1) from the end of the turn signal wire vinyl conduit (4) still connected to the switch housing.
- Make about a 25 mm (1 in) long slit in the end of the conduit. Cut one wire back about 12 mm (1/2 in) from the end of the conduit. Cut the second wire back about 6 mm (1/4 in) from the end of the conduit.
- Slip the 50.8 mm (2 in) long section of encapsulating (dual wall) shrink tube (5) over the conduit and wires.

NOTE

Installation of protective shrink tubing over wire leads is necessary in the relocation of the turn signals on the motorcycle.

▲ WARNING

Be sure to follow manufacturer's instructions when using the UltraTorch UT-100 or any other radiant heating device. Failure to follow manufacturer's instructions can cause a fire, which could result in death or serious injury. (00335a)

- Avoid directing heat toward any fuel system component. Extreme heat can cause fuel ignition/explosion resulting in death or serious injury.
 - Avoid directing heat toward any electrical system component other than the tubing on which heat shrink work is being performed.
 - Always keep hands away from tool tip area and heat shrink attachment.
6. Use a heat gun or suitable radiant-heating device to shrink the tubing to the wires and conduit.

NOTE

Make sure wires are not pinched between upper and lower housings.

7. Assemble the switches and switch housings to the handlebar per service manual instructions, tucking the shrink-sealed wire ends back inside the switch housings. Repeat Steps 1-7 on the opposite side of the vehicle.
8. Remove one of the front turn signal lamps and wires from the vehicle per the service manual. The ball stud, clamp, jam nut, retainer and washer can be recycled or properly disposed of. Cut the conduit back a little to expose the wires for splicing.
9. Hold the mirror in place while removing the acorn nut and lockwasher. Remove the turn signal mounting bracket from the vehicle. Install the lockwasher onto the mirror threads, and fasten with a **new**, longer acorn nut from the FLD Auxiliary Lamp Mounting Kit. Tighten the acorn nut to 9.5–17.6 N·m (84–156 **in-lbs**) Recycle or properly dispose of the turn signal mounting bracket and original equipment (OE) acorn nut.
10. Repeat steps 8-9 for the remaining turn signal lamp.
11. Install the front turn signal lamps to the auxiliary lamp mounting bars per the instructions in the FLD Auxiliary Lamp Mounting Kit.

NOTE

Splicing of wire leads is necessary in the relocation of the turn signals on the motorcycle. Refer to the service manual appendix for proper wire splicing procedures.

12. See Figure 4. Get the six wires (9, 10, 11), six wire connectors (12) and six pieces of shrink tube (13) from the kit. Cut and strip the ends of each wire per the instructions in the service manual appendix. Slide a piece of shrink tube onto one end of each of the six wires.
13. Cut and strip the ends of each wire coming from the turn signal lamps, staggering the ends a bit to avoid all three splices of one lamp being together.

14. Using the wire connectors, follow the instructions in the service manual appendix to splice each 0.6 m (24 in) long wire to the corresponding color wire from one of the turn signal lamps.
15. Slide the shrink tube over each wire connector.
16. Use the heat gun or suitable radiant-heating device to seal the shrink tubes around the wire connections.

NOTE

If necessary, apply a light coat of liquid soap, window cleaner or all-purpose lubricant to the inside and outside of the protective tubing.

17. Get the two wire conduits (14) from the kit. Slide a conduit over the three wires coming from each turn signal lamp.
18. Route the turn signal wires and conduits back to the location of the six-way pin housing [31A], just in front of the fuel tank on the left side. Cut the wires and conduit to comfortably reach the connector, allowing for rotation of the steering head from lock to lock.
19. Get the six-way socket housing (16) and six socket terminals (15) from the kit. Install the terminals onto the wire ends per the service manual. Insert the wires and terminals into the correct cavities of the socket housing.
 - Right turn signal **black** wire to cavity 1
 - Right turn signal **brown** wire to cavity 2
 - Right turn signal **blue** wire to cavity 3
 - Left turn signal **blue** wire to cavity 4
 - Left turn signal **violet** wire to cavity 5
 - Left turn signal **black** wire to cavity 6
20. Connect the socket housing to pin housing [31A].

NOTE

The windshield spring retainers (Items 5 and 6) in this kit are side-specific. They install with the thumb grip end shifted toward the outer edges of the windshield.

▲ WARNING

Be sure that steering is smooth and free without interference. Interference with steering could result in loss of vehicle control and death or serious injury. (00371a)

21. **If installing a windshield**, replace the windshield spring retainers with the offset retainers from **THIS** kit.
 - a. See Figure 3. Remove the acorn nut (1), chrome washer (2) and black nylon "top hat" bushing (3) from one windshield mounting bracket. Remove the windshield retaining spring (4). The black nylon washer (7) and the second "top hat" bushing (3) can remain in position on the screw (8) threads.
 - b. Get the correct **new** offset windshield retaining spring (5) from the kit. Install the spring onto the screw threads, between the bushings (3).

- c. Install the chrome washer and acorn nut. Rotate the retaining spring to the approximate position of the original spring, and tighten the nut securely. Repeat Steps a-c on the other side of the windshield.

22. Install the windshield to the vehicle per the provided instructions. If adjustment to the retaining springs is necessary, loosen the retaining screws and acorn nuts and rotate the springs into proper position.

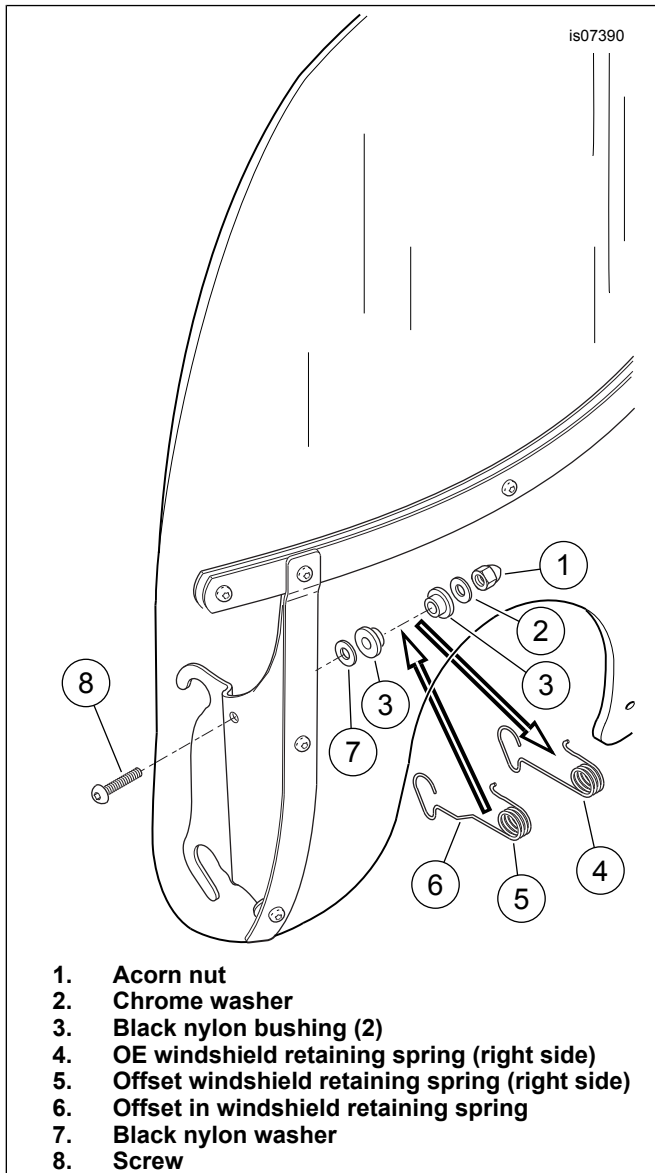

Figure 3. Windshield Modification for Auxiliary Lamp Bracket

RETURN TO SERVICE

NOTE

Verify that the ignition key switch is in the OFF position **before** installing the main fuse or attaching the negative battery cable.

1. **Models with main fuse:** See the service manual and install the main fuse. **Models with main circuit breaker:** See the service manual and attach the negative battery cable. Apply a light coat of Harley-Davidson electrical contact lubricant (Part No. 99861-02), petroleum jelly or corrosion retardant material to the negative battery terminal.

⚠ WARNING

After installing seat, pull upward on seat to be sure it is locked in position. While riding, a loose seat can shift causing loss of control, which could result in death or serious injury. (00070b)

2. **For ALL models:** See the service manual and install the seat.

SERVICE PARTS

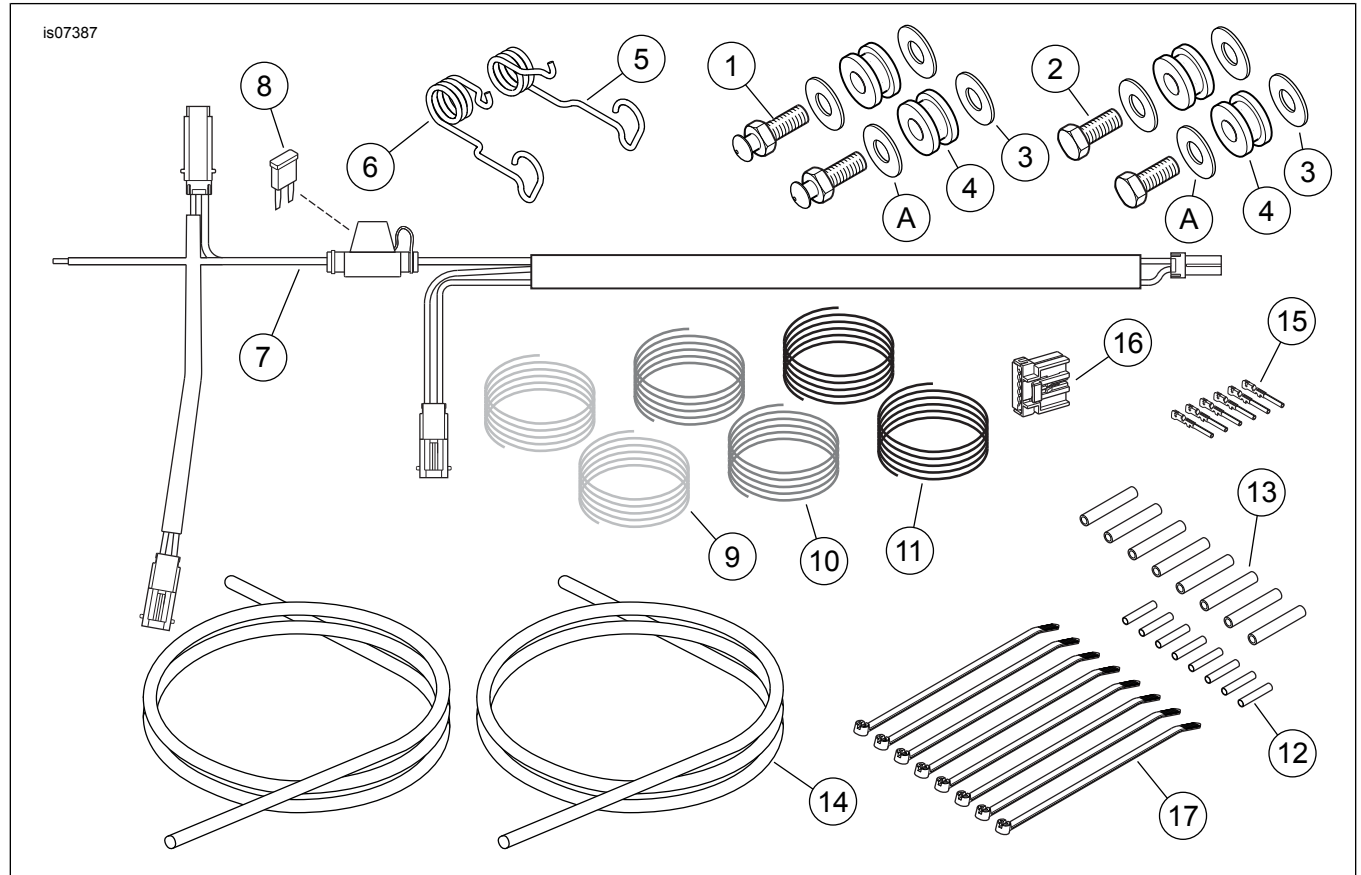

Figure 4. Service Parts, FLSTF Auxiliary Lamp Mounting and Turn Signal Relocation Hardware Kit

Table 1. Service Parts

Item	Description (Quantity)	Part Number
1	Upper mounting pin, detachable windshield, mushroom head (2)	Not sold separately
2	Cap screw, hex head, 5/16-24 x 32 mm (1.25 in) (2)	94215-91T
3	Plain washer, 14 mm (9/16 in) OD (4)	Not sold separately
4	Bushing, windshield (4)	67621-94
5	Spring retainer, windshield (right)	Not sold separately
6	Spring retainer, windshield (left)	Not sold separately
7	Wire harness, FLSTF/B passing lamp (includes Item 8)	Not sold separately
8	• Fuse, mini blade type, 10 Amp (red)	72462-00
9	Wire, blue, 0.64 m (25 in) long (2)	Not sold separately
10	Wire, violet, 0.64 m (25 in) long (2)	Not sold separately
11	Wire, black, 0.64 m (25 in) long (2)	Not sold separately
12	Wire connector (8)	Not sold separately
13	Shrink tube, encapsulating (dual wall), 51 mm (2 in) long (8)	72411-97
14	Conduit, wire, 0.61 m (24 in) long (2)	Not sold separately
15	Socket terminal (6)	73191-96
16	Socket housing, six-way	73156-96BK
17	Cable strap (8)	10065
Item mentioned in text, but not included in kit:		
A	Chrome washer (4, Part No. 6373) from FLD Auxiliary Lamp Mounting Kit	