



# INSTRUCTIONS

J06145

2015-05-01



## ROAD GLIDE LED BULLET FOG LAMP MOUNTING KITS

### GENERAL

#### Kit Numbers

68000183, 68000184

#### Models

For model fitment information, see the P&A retail catalog or the Parts and Accessories section of [www.harley-davidson.com](http://www.harley-davidson.com) (English only).

#### Installation Requirements

**Separate purchase** of an LED Bullet Fog Lamp Kit (Part No. 68000090 or 68000092) is required for proper installation of this kit. See the P&A retail catalog or the Parts and Accessories section of [www.harley-davidson.com](http://www.harley-davidson.com) (English only).

Temporary use of two common 1/4-20 nuts (not provided) is required for the fog lamp alignment procedure.

Loctite<sup>®</sup> 243 Medium Strength Threadlocker and Sealant - Blue (Part No. 99642-97) is required for proper installation of this kit.

These items are available from a Harley-Davidson dealer.

#### ⚠ WARNING

**Rider and passenger safety depend upon the correct installation of this kit. Use the appropriate service manual procedures. If the procedure is not within your capabilities or you do not have the correct tools, have a Harley-Davidson dealer perform the installation. Improper installation of this kit could result in death or serious injury. (00333b)**

#### NOTE

*This instruction sheet refers to service manual information. A service manual for this year/model motorcycle is required for this installation. One is available from a Harley-Davidson dealer.*

### Kit Contents

See Figure 7 and Table 1.

### PREPARATION

#### ⚠ WARNING

**To prevent accidental vehicle start-up, which could cause death or serious injury, remove main fuse before proceeding. (00251b)**

#### NOTE

- **WITH security siren:** With security fob present, turn ignition switch ON. See the service manual. Disarm security system. Turn ignition switch OFF. **IMMEDIATELY** remove the main fuse.

- **WITHOUT security siren:** See the service manual. Remove main fuse.

### REMOVAL

1. Lay a clean pad or blanket on the work surface to protect the painted surfaces of the outer fairing.
2. Remove windshield. Remove outer fairing. See the service manual.
3. Disconnect the turn signal wiring from the mating connectors on the inner fairing. Record wire routing inside the outer fairing. Peel back the adhesive-backed wire retention pads to free the wiring. Cut the turn signal wires **about 125–152 mm (5–6 in) from the inner fairing connector** to enable turn signal removal from stalk. Remove turn signal mount from inside the outer fairing. Save turn signal, mount and connector for reuse.
4. Place the outer fairing, bottom down, on the protected work surface.

#### NOTE

*The drill guides are side-specific. Guides fit into cavities in the fairing at the turn signal mounting location.*

5. See Figure 7. Get the drill guides (9, 10) from the kit. Temporarily position one drill guide into the correct turn signal mounting cavities on one side of the fairing. Note the areas where the drill guide is in contact with the fairing paint.
6. Remove the drill guide. Lay strips of masking tape onto the fairing surface to protect the finish where the drill guide contacts the fairing.
7. Position the drill guide back into the turn signal mounting cavities. Secure with masking tape.
8. Carefully insert a 6 mm (1/4 in) drill bit through the drill guide. Drill a hole through the fairing. Remove the drill. Remove the drill guide.

#### NOTE

- **READ ALL DIRECTIONS** for enlarging the hole **BEFORE STARTING**.
- **FAILURE TO FOLLOW THESE DIRECTIONS** could result in a visible gap between the turn signal stalk and fairing.

9. Carefully enlarge the hole per the following directions, using a 16 mm (5/8 in) diameter drill bit:
  - a. See Figure 1. When enlarging the hole, drill **perpendicular to the fairing (1) surface (2)** to avoid the bit "walking" and marring the finish.
  - b. Once through the hole, continue power to the drill. Tip the drill into the fairing **as though parallel to the ground (3)** in installed position to elongate the hole vertically.

c. **DO NOT oversize the hole!** Use a coarse round file of 13 mm (1/2 in) diameter or less to remove excess fairing material slowly. Test-fit the turn signal stalk into the hole often to get a snug fit around the boss on the stalk.

10. Repeat steps 5-9 on the opposite side.

11. See Figure 2. Remove and discard the bolt (3) and washer from the engine guard support (2) on the inner fairing (1). Support the rear part of the inner fairing if necessary. Repeat on other side.

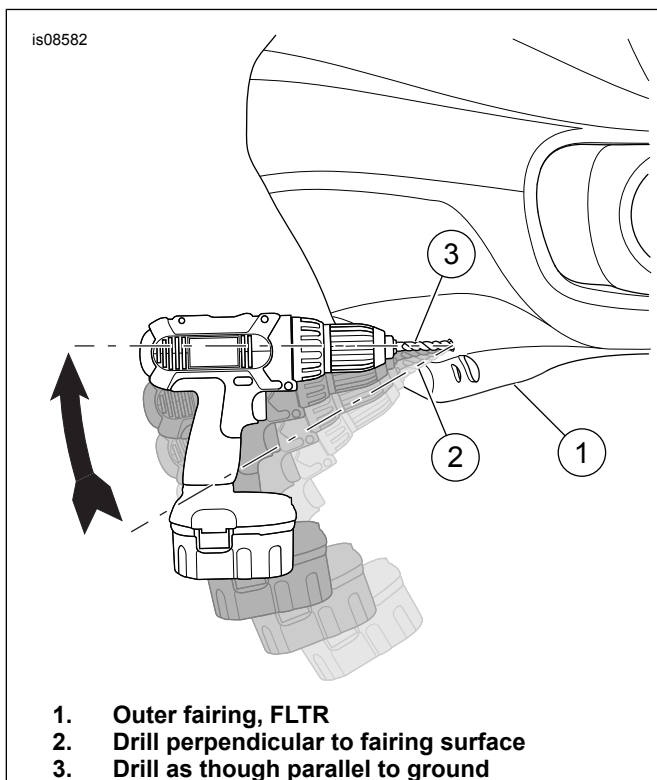

Figure 1. Drill Elongated Hole

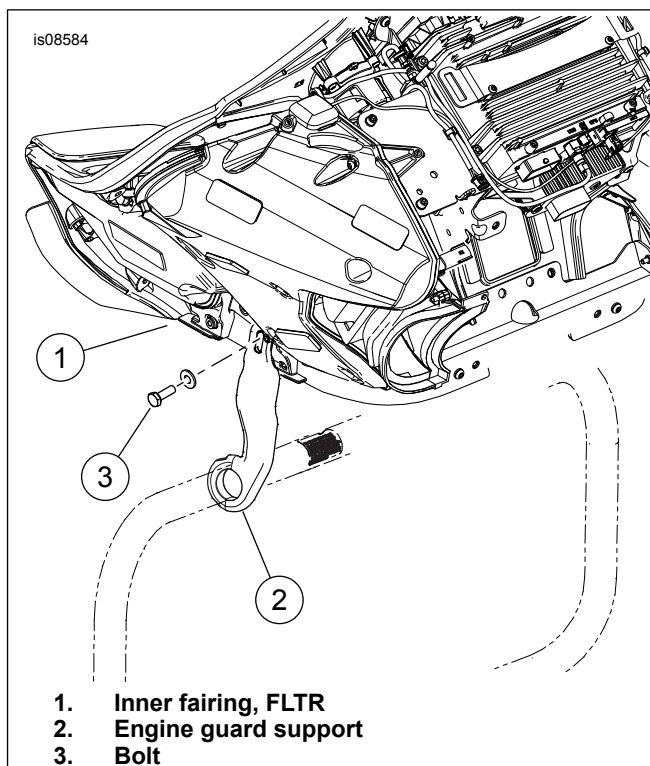

Figure 2. Remove Bolt From Engine Guard Support

## TEMPORARY ASSEMBLY FOR LAMP ALIGNMENT

### NOTE

See Figure 3. Due to limited access to mounting screws, fog lamps (1) **MUST** be aligned before final installation.

The fog lamps and gaskets are side-specific.

- Fog lamps must be installed with the Bar & Shield logo at the top.
- Back side of gasket has an embossed letter "R" (right) or "L" (left).

1. See Figure 4. Get the correct-side turn signal standoff (1) and gasket (4) from **this** kit. Get the correct-side fog lamp (11) from **the LED Bullet Fog Lamp Kit**. Get the original equipment (OE) turn signal lamp (2), screw (5) and the correct-side turn signal mount (9) removed earlier.
2. Feed the **turn signal** wiring through the rear hole in the standoff and the large hole in the gasket.
3. Feed the **fog lamp** wiring through the large hole in the gasket. Slide the gasket over the long boss of the standoff. Capture the fog lamp wiring between the gasket and the notch in the standoff.
4. Feed the turn signal and fog lamp wiring through the rectangular opening in the turn signal mount.
5. Temporarily assemble the turn signal lamp (2), gasket (4), standoff (1) and mount (9) with screw (5). Tighten securely.
6. Get a fog lamp bracket (3), long screw (8) and a common 1/4-20 nut (10, not provided). Temporarily assemble the bracket to the standoff with the screw and nut. Rotate the fog lamp bracket toward the rear until it stops (see Figure 3, Item 2). Tighten screw and nut sufficiently to hold position.

7. See Figure 4. Get the short screw (6) and split lockwasher (7) from the kit .
8. Insert the screw through the fog lamp bracket (3) as shown. Place the lockwasher (7) into the counterbore in the bracket, over the screw threads. Apply a few drops of Loctite 243 - Blue to the **clean** screw threads. Thread the screw into the fog lamp, but do not fully tighten.
9. See Figure 3. Align the fog lamp (1) parallel to the turn signal lamp (4). Tighten the fog lamp screw per fog lamp kit instructions.
10. Repeat steps for the opposite side.

**NOTE**

After final installation, fog lamps are adjustable through a range from straight ahead (5) to two degrees downward (6) by loosening screw (3).

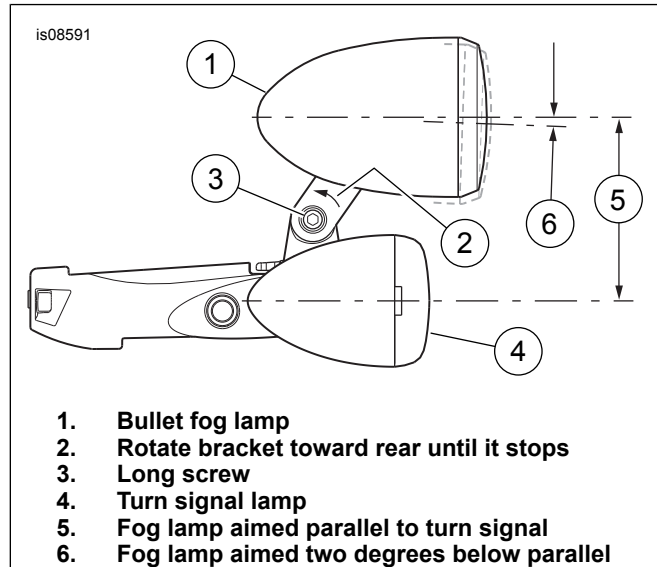

**Figure 3. Fog Lamp Alignment**

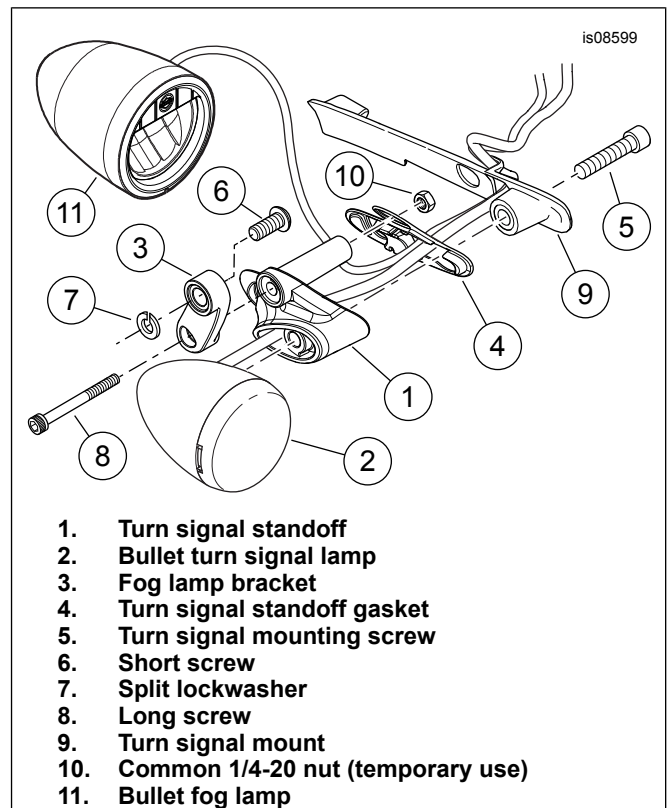

**Figure 4. Temporary Lamp Assembly (Right Side Shown)**

**INSTALLATION**

1. See Figure 4. Remove turn signal screw (5) and bracket (9) from one lamp and standoff assembly.
2. Place bracket inside fairing in original position. Feed the turn signal and fog lamp wiring through the rearmost hole in the outer fairing, and the rectangular opening in the turn signal mount. Install turn signal screw through turn signal bracket boss, gasket and standoff. Thread into the turn signal, but do not fully tighten.

**NOTE**

*Gently tug the wires to remove excess slack outside the fairing. Make sure that the fog lamp wire is not pinched, and remains routed between the standoff and gasket through the notch.*

*Route the wires behind the formed hook in the turn signal mount.*

3. Tighten the turn signal screw per the service manual.
4. Repeat on other side.
5. Use a sealed splice connector (11) from the kit to secure the (V/BN) connector wire to the (V/BN) wire from the turn signal. See Figure 5, Item 6. Use a second sealed splice connector to secure the (BE) connector wire to the (BE) wire from the turn signal. Leave the (BK) wires cut for now.
6. Cut the fog lamp wires close to the two-way connector. Discard the connector.

7. Measure about 200 mm (8 in) from the end of the fog lamp wires.
  - a. Remove 25–50 mm (1–2 in) of the outer sleeve at that location.
  - b. Cut the (BK) wire inside the gap farthest from the fog lamp. Pull the excess (BK) wire from the end of the wire sleeve.
  - c. See Figure 5. Use a sealed splice connector (6) from the kit to secure the (BK) fog lamp wire to the (BK) turn signal wires cut earlier.
8. See Figure 6. Insert a fog lamp jumper wire harness (6) from the kit into cavity 4 of connector [31B]. Use a sealed splice connector to secure the (R) fog lamp wire to the (BE/BK) jumper wire.

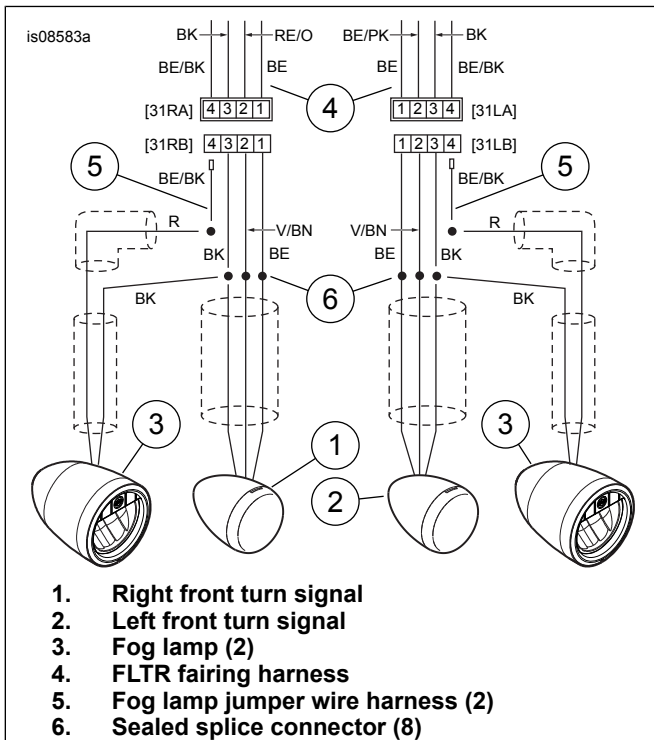

Figure 5. Wiring Diagram, Road Glide LED Bullet Fog Lamps

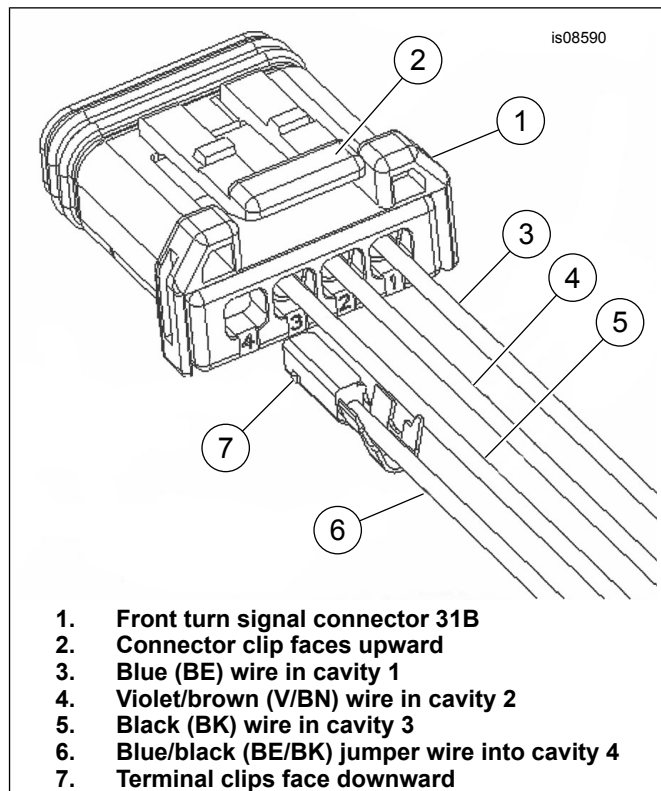

Figure 6. Insert Jumper Terminal Into Cavity 4

9. Repeat steps 1-8 on the opposite side.
10. Secure the turn signal wiring and fog lamp wires under the adhesive-backed wire retention pads peeled back earlier. Replace any damaged pads (F, available separately).
11. Secure excess wire with tape or cable straps in original locations.
12. Position outer fairing near the front of the vehicle. Connect turn signal wiring.
13. Get the two long screws (8) from the kit. Apply a few drops of Loctite 243 - Blue to the **clean** screw threads.
14. Install the outer fairing per the service manual, with the following exception:
  - a. Use long screws (8, installed earlier with temporary nuts) from **this** kit to secure the fog lamp (Item B) bracket (5) to the turn signal standoff (1, 2).
  - b. Remove and discard temporary nuts. Hand thread screw (8) into the inner fairing media box. NOTE: It could take a few tries to get the media box threaded insert to engage the screw threads.
  - c. Once the screw threads are engaged, tighten to 10.2 N·m (7.5 ft-lbs). **DO NOT OVER-TIGHTEN!** Over-tightening could damage threaded inserts in media box.
  - d. Repeat on other side.
15. **Models WITHOUT fog lamp switch:** See:

- the parts catalog for this model vehicle,
- the Parts and Accessories section of [www.harley-davidson.com](http://www.harley-davidson.com) (English only) or
- a Harley-Davidson dealer

for an OE fog lamp switch. Install the switch per the service manual.

## SERVICE PARTS

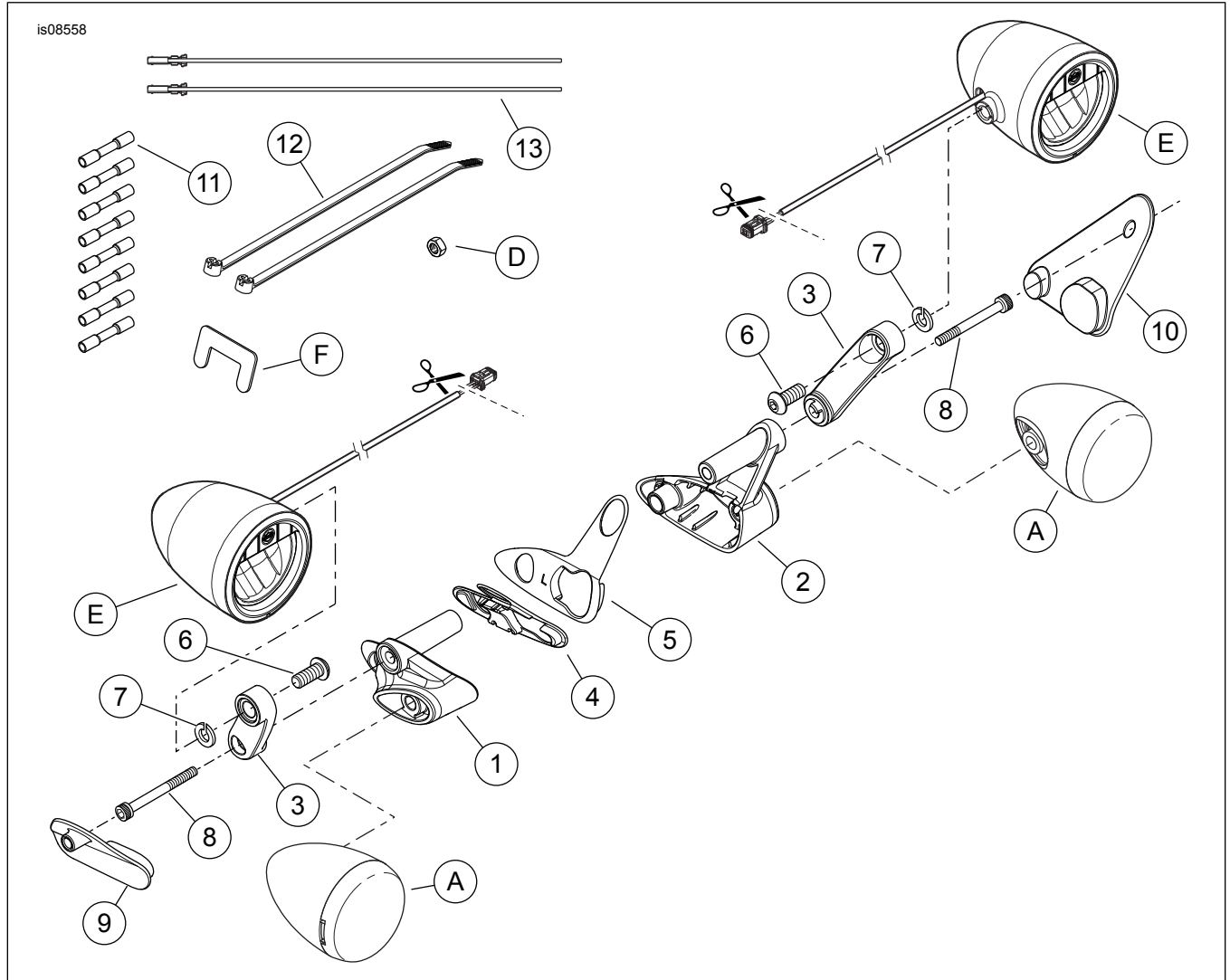

Figure 7. Service Parts, Road Glide LED Auxiliary Lamp Kits

## SERVICE PARTS

Table 1. Service Parts

Kit	Item	Description (Quantity)	Part Number
Kit 68000183 (Chrome)	1	Standoff, turn signal (right, Chrome)	67800558
	2	Standoff, turn signal (left, Chrome)	67800559
	3	Bracket, fog lamp (Chrome) (2)	68000185
Kit 68000184 (Black)	1	Standoff, turn signal (right, Black)	67800560
	2	Standoff, turn signal (left, Black)	67800561
	3	Bracket, fog lamp (Black) (2)	68000186

## COMPLETION

### NOTE

To prevent possible damage to the sound system, verify that the ignition switch is OFF **before** installing the main fuse.

1. See the service manual. Install main fuse.

**Table 1. Service Parts**

<b>Kit</b>	<b>Item</b>	<b>Description (Quantity)</b>	<b>Part Number</b>	
Parts common to BOTH kits	4	Gasket, right	68000187	
	5	Gasket, left	68000188	
	6	Screw, hex socket button head, 5/16-18 x 19 mm (3/4 in) (Chrome) (2)	Not sold separately	
	7	Lockwasher, split, 5/16 in, stainless steel (2)	Not sold separately	
	8	Cap screw, hex socket head, 1/4-20 x 83 mm (3 1/4 in) long, Grade 8 (2)	10500081	
	9	Drill guide (right)	Not sold separately	
	10	Drill guide (left)	Not sold separately	
	11	Sealed splice connector (8)	70585-93	
	12	Cable strap (2)	10065	
	13	Wire harness, fog lamp jumper (2)	69201503	
	<b>Items mentioned in text, but not included in kit:</b>			
		A	Original equipment (OE) turn signal lamp (2)	
		B	OE turn signal mount (2)	
	C	OE turn signal screw (2)		
	D	1/4-20 nut (2, for temporary use)		
	E	LED Fog Lamp Kit (separate purchase)		
	F	Adhesive-backed wire retention pad (Part No. 11100066)		