



INSTRUCTIONS

J05934

2014-08-19



LED BULLET FOG LAMP MOUNTING KITS

GENERAL

Kit Numbers

68000141, 68000142, 68000170, 68000171

Models

For model fitment information, see the P&A retail catalog or the Parts and Accessories section of www.harley-davidson.com (English only).

This kit is designed for use only with 31.8 mm (1 1/4 in) diameter engine guards that are vertical when viewed from the front with the motorcycle upright.

Harley-Davidson recommends inboard mounting of engine guard fog lamps

This kit is not compatible with soft fairing lowers.

Installation Requirements

NOTE

FL Touring and Trike models with Color-Matched Fairing Lowers require use of the long brackets from kit 68000170 (Chrome) or 68000142 (Black).

Separate purchase of an Engine Guard Mounted LED Bullet Fog Lamp Kit and a Fog Lamp Wire Harness Kit are required for proper installation of this kit.

Loctite® 243 Medium Strength Threadlocker and Sealant - Blue (Part No. 99642-97) is required for proper installation of this kit.

Electrical Contact Lube (H-D Part No. 99861-02) or equivalent is required after battery cable disconnection.

These items are available from a Harley-Davidson dealer.

Kit Contents

See Figure 1 and Table 1.

PREPARATION

⚠ WARNING

To prevent accidental vehicle start-up, which could cause death or serious injury, remove main fuse before proceeding. (00251b)

NOTE

- **For 2007- later vehicles WITH security siren:** With security fob present, turn ignition switch ON. See the service manual. After system is disarmed, turn ignition switch OFF. **IMMEDIATELY** remove the main fuse.
- **For 2006- earlier vehicles WITH security siren:** Disarm the siren with the key fob or security code. See the service manual to remove the main fuse.

- **For vehicles WITHOUT security siren:** See the service manual. Remove the main fuse.

INSTALLATION

NOTE

- To meet regulations, mount the brackets so the bottom of the fog lamp housing is a minimum of 250 mm (9.85 in) from the ground with the motorcycle upright.
- These fog lamps can be mounted either inboard or outboard of the engine guards. Harley-Davidson recommends inboard mounting of engine guard fog lamps. These instructions describe inboard mounting.

Short Clamp Installation

1. See Figure 1. Get an engine guard clamp (1), screw (2) and lockwasher (6) from **this** kit.
2. Open the clamp. Place the clamp around the vertical section of the engine guard with the hinge rearward and the deep counterbore (A) inward.
3. Insert the screw through the clamp from the shallow counterbore (B) side. Slide the lockwasher onto the screw threads, into the deep counterbore.
4. Apply a few drops of Loctite 243 - Blue to the **clean** threads of the screw.

NOTE

The fog lamps are side-specific. The fog lamps must be installed with the Bar & Shield logo at the top.

5. Get the correct fog lamp from the Engine Guard Mounted LED Bullet Fog Lamp Kit.
6. Thread the screw (2) into the fog lamp, but do not fully tighten.

NOTE

To meet regulations, mount the brackets so the bottom of the fog lamp housing is a minimum of 250 mm (9.85 in) from the ground with the motorcycle upright.

7. Aim the fog lamp straight ahead vertically and horizontally. Tighten securely.
8. Repeat steps 1-7 for the remaining clamp and fog lamp.

Installation With Long Clamps

1. See Figure 1. Get an engine guard clamp (3) and long screw (4) from **this** kit.
2. Open the clamp. Place the clamp around the vertical section of the engine guard with the hinge rearward and the deep counterbore (A) inward.



3. Insert the screw through the hole in the short side of the clamp. Apply a few drops of Loctite 243 - Blue to the **clean** threads of the screw.
4. Thread the screw into the long side of the clamp, but do not fully tighten.

NOTE

To meet regulations, mount the brackets so the bottom of the fog lamp housing is a minimum of 250 mm (9.85 in) from the ground with the motorcycle upright.

5. Adjust the clamp to the desired height according to the note at the beginning of this section. Aim the long side of the clamp straight ahead. Tighten the screw securely.

NOTE

The fog lamps are side-specific. The fog lamps must be installed with the Bar & Shield logo at the top.

6. Get the correct fog lamp from the Engine Guard Mounted LED Bullet Fog Lamp Kit, and a short screw (5) and lockwasher (6) from **this** kit.
7. Insert the screw through the long side of the clamp from the shallow counterbore (B) side. Slide the lockwasher onto the screw threads, into the deep counterbore.
8. Apply a few drops of Loctite 243 - Blue to the **clean** threads of the screw.
9. Thread the screw into the fog lamp, but do not fully tighten.
10. Aim the fog lamp straight ahead vertically. Tighten securely.
11. Repeat steps 1-10 for the remaining clamp and fog lamp.

Electrical Connection

Complete the fog lamp installation per the instructions in the Fog Lamp Wire Harness Kit.

IN USE

Check mounting screw tightness regularly.

SERVICE PARTS

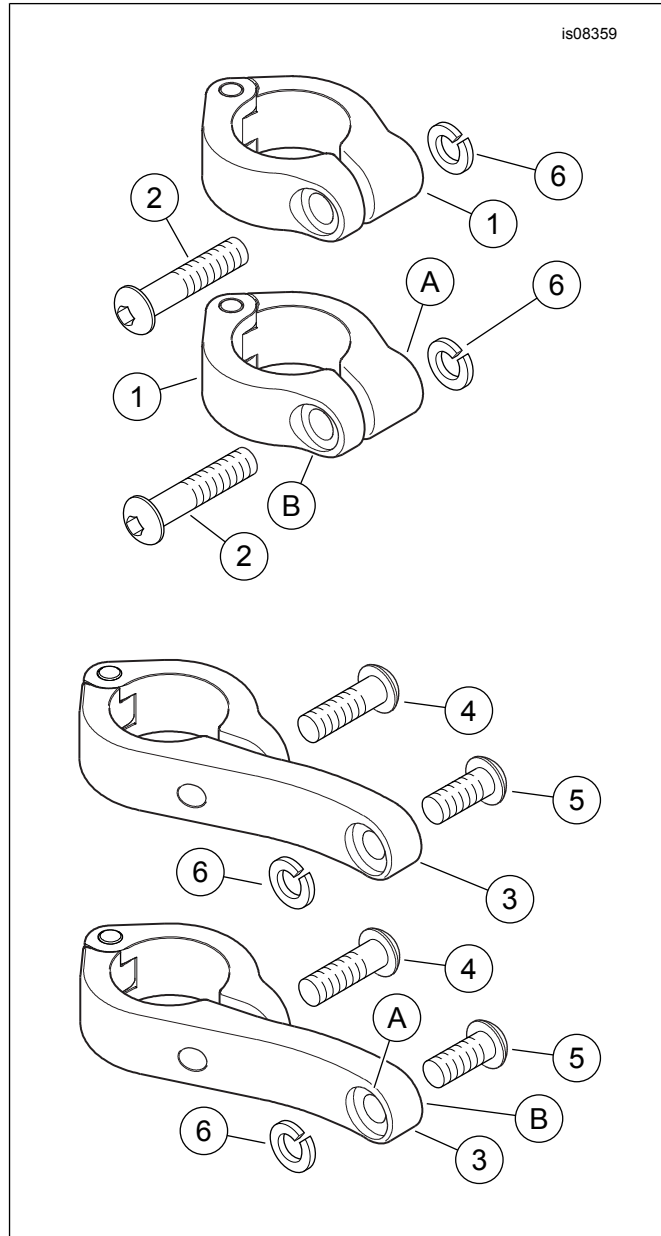

Figure 1. Service Parts, LED Bullet Fog Lamp Mounting Kits

Table 1. Service Parts

Item	Description (Quantity)	Part Number
For Kit 68000171 (Short, Chrome):		
1	Engine guard clamp, short (Chrome) (2)	68000124
2	Screw, button head 5/16-18 x 38 mm (1.5 in) long, Chrome (2)	Not sold separately
For Kit 68000141 (Short, Black):		
1	Engine guard clamp, short (Black) (2)	68000143
2	Screw, button head 5/16-18 x 38 mm (1.5 in) long, Chrome (2)	Not sold separately
For Kit 68000170 (Long, Chrome):		
3	Engine guard clamp, long (Chrome) (2)	68000125

Table 1. Service Parts

Item	Description (Quantity)	Part Number
4	Screw, button head 5/16-24 x 25 mm (1.0 in) long, Chrome (2)	Not sold separately
5	Screw, button head 5/16-18 x 19 mm (0.75 in) long, Chrome (2)	Not sold separately
For Kit 68000142 (Long, Black):		
3	Engine guard clamp, long (Black) (2)	68000144
4	Screw, button head 5/16-24 x 25 mm (1.0 in) long, Chrome (2)	Not sold separately
5	Screw, button head 5/16-18 x 19 mm (0.75 in) long, Chrome (2)	Not sold separately
For ALL Kits:		
6	Split lockwasher, 5/16-in, stainless steel (2)	Not sold separately
Items mentioned in text.		
A	Deep counterbore	
B	Shallow counterbore	