



INSTRUCTIONS

J05936

2015-10-15



SADDLEBAG SUPPORT KIT

GENERAL

Kit Number

90201324, 90201433

Models

For model fitment information, see the P&A Retail Catalog or the Parts and Accessories section of www.harley-davidson.com (English only).

Installation Requirements

Separate purchase of more parts or accessories could be required for proper installation of this kit. Parts can be purchased separately from a Harley-Davidson dealer.

⚠ WARNING

Rider and passenger safety depend upon the correct installation of this kit. Use the appropriate service manual procedures. If the procedure is not within your capabilities or you do not have the correct tools, have a Harley-Davidson dealer perform the installation. Improper installation of this kit could result in death or serious injury. (00333b)

NOTE

This instruction sheet references service manual information. A service manual for your model motorcycle is required for this installation. One is available from a Harley-Davidson dealer.

Kit Contents

See Figure 3 and Table 1.

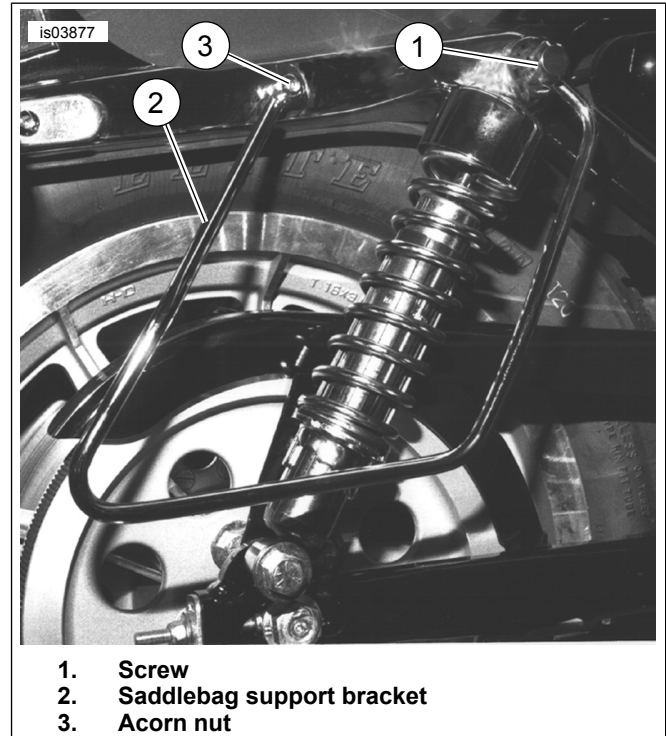

Figure 1. Soft Saddlebag Support Bracket Installation

INSTALLATION

1. If necessary install a Directional Relocation Kit, complete the installation of that kit before installing this Saddlebag Support Kit.

NOTE

Secure the motorcycle in a straight upright position.

Complete the saddlebag support installation on one side of the vehicle before beginning the other side.

2. See Figure 2. Remove the 1/2-13 bolt (1), washer (2) and shock absorber cover (3). Discard the bolt and cover, but retain the washer for later installation.

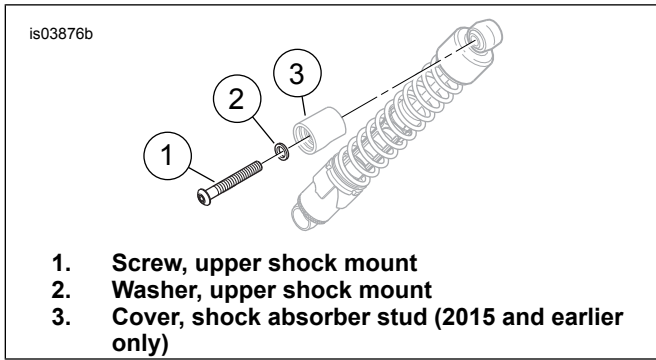

Figure 2. Rear Shock Absorber Upper Mount

3. See Figure 1. Remove the frontmost O. E. button head bolt and nut (at 3) from the fender support cover. **On 2000-2003 models**, discard the bolt, but retain the nut for later installation. **On 2004 and later models EXCEPT XL1200N**, discard the bolt and nut. **On XL1200N models**, discard the bolt, but retain the nut for later installation.
4. See Figure 3. Position the support bracket (3) with the front mounting hole over the shock absorber stud and the rear mounting hole over the hole in the fender support.

NOTE

Hold the wire retention bracket in position in the fender while inserting the bolt through the fender support and fender. The bracket can be difficult to install or can be damaged if dislodged.

NOTE

When performing the following step:

- **2000-2003 models with** sissy bar side plates, use the 2-7/8 in (73 mm) long bolt (1) from the kit, and the nut (C) removed in Step 3.

- **2000-2003 models without** sissy bar side plates, use the 2-3/4 in (70 mm) long bolt (2) from the kit, and the nut (C) removed in Step 3.
 - **2004 and later models except XL1200N**, use the 3-1/4 in (83 mm) long screw (6), spacer (8) and locking acorn nut (7) from the kit.
 - **XL1200N models**, use the 3-1/4 in (83 mm) long screw (6) from the kit, and the nut (C) removed in Step 3.
5. **2000-2003 models**, install the saddlebag support to the vehicle by inserting the correct bolt (1 or 2) through the rear support mounting hole, the rear fender support cover, fender support frame rail, rear fender and wire retention bracket. Fasten with the nut removed in Step 3. Tighten to 10.8–17.6 N·m (96–156 **in-lbs**). **2004 and later models EXCEPT XL1200N**, install the saddlebag support to the vehicle by inserting the bolt (6) through the wire retention bracket, rear fender, fender support frame rail, rear fender support cover and rear saddlebag support mounting hole. Place the spacer washer (8) onto the screw threads. Install the locking acorn nut (7). Tighten to 10.8–17.6 N·m (96–156 **in-lbs**). **XL1200N models**, install the saddlebag support to the vehicle by inserting the bolt (6) through the rear support mounting hole, the rear fender support cover, fender support frame rail, rear fender and wire retention bracket. Fasten with the nut removed in Step 3. Tighten to 10.8–17.6 N·m (96–156 **in-lbs**).
 6. Secure the front of the saddlebag support bracket. Secure the upper shock absorber mount, using the 1/2-13 hex head screw (5) from the kit. Tighten the screw to 61–68 N·m (45–50 ft-lbs).
 7. Repeat previous step on opposite side.

SERVICE PARTS

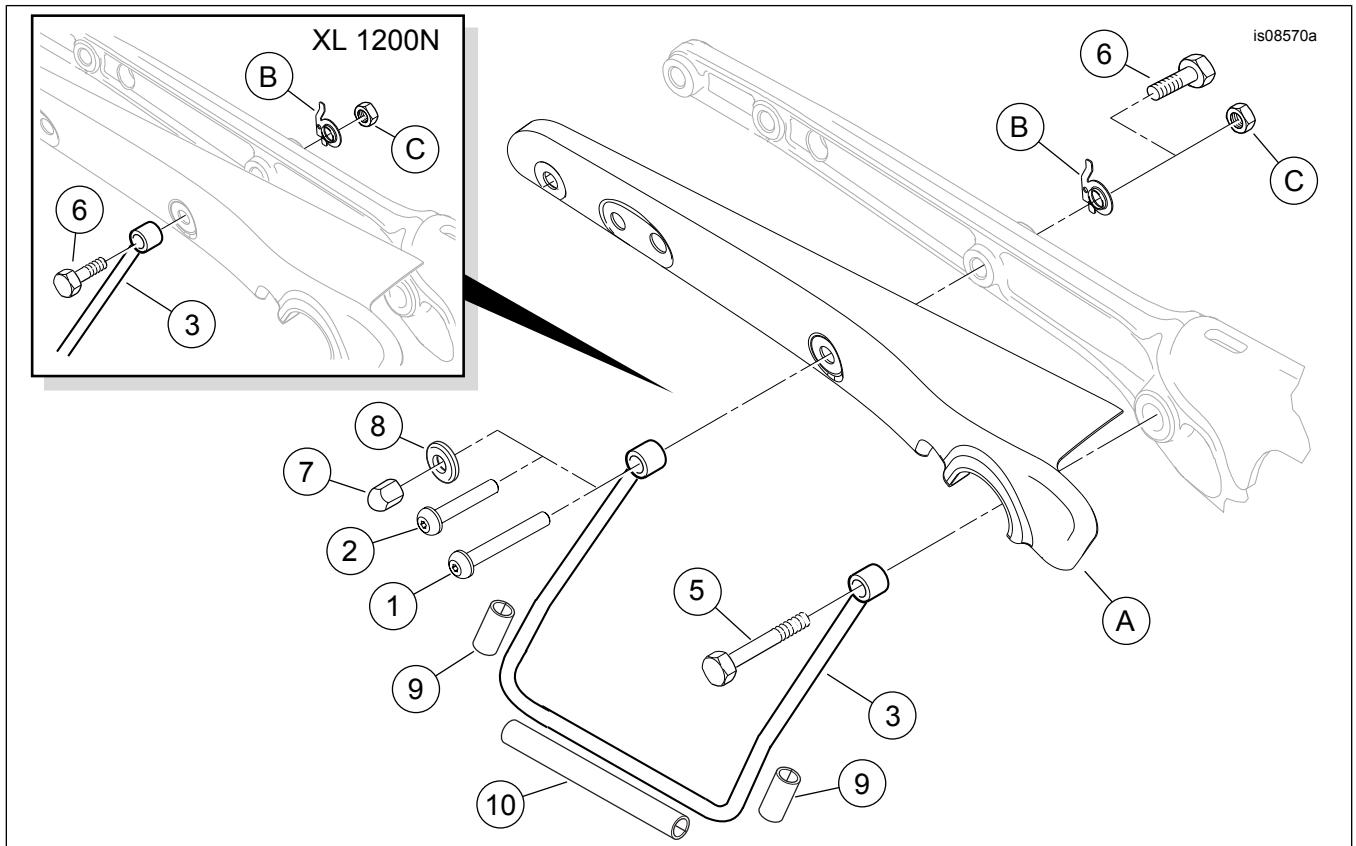

Figure 3. Service Parts, Saddlebag Support Kit

Table 1. Service Parts Table

Item	Description (Quantity)	Part Number
1	Screw, pan head, TORX 5/16-18 x 2-7/8 in (2)	10200420
2	Screw, pan head, TORX 5/16-18 x 2-3/4 in (2)	10200419
3	Saddlebag support, chrome (right side)	90847-94B
	Saddlebag support, black (right side)	90201435
4	Saddlebag support, chrome (left side, not shown)	90850-94B
	Saddlebag support, black (left side, not shown)	90201434
5	Cap screw, hex head, 1/2-13 x 3-1/2 in (2)	10200417
6	Screw, hex head, 5/16-18 x 3-1/4 in (2) (for 2004 and later models)	10200416
7	Acorn nut, locking (2) (for 2004 and later models, except XL 1200N)	7549A
8	Spacer, 1/8 in thick (2) (for 2004 and later models, except XL 1200N)	6109
9	Protector, short, (4) (for kit 90201433 only)	11100161
10	Protector, long, (2) (for kit 90201433 only)	11100162
Items mentioned in text, but not included in kit:		
A	Rear fender support cover	
B	Wire retention bracket	
C	Fender retaining hex nut	