



INSTRUCTIONS

J06172

2015-05-15



SCREAMIN' EAGLE PRO TWIN CAM 110 (1800 CC) BOLT-ON CONVERSION KIT

GENERAL

Kit Number

92500031

Models

For model fitment information, see the P&A Retail Catalog or the Parts and Accessories section of www.harley-davidson.com (English only).

Installation Requirements

Separate purchase and installation of extra parts or accessories may be required for proper installation of this kit. See the P&A Retail Catalog or the Parts and Accessories section of www.harley-davidson.com (English only).

Proper installation of this kit also requires the use of Digital Technician™ at a Harley-Davidson dealer or a separate purchase of Screamin' Eagle Street Performance Tuner Kit .

NOTE

Do not use stock CVO pistons with the 4" Bolt-on Cylinders or interference will occur between the pistons and crankcase.

▲ WARNING

Rider and passenger safety depend upon the correct installation of this kit. Use the appropriate service manual procedures. If the procedure is not within your capabilities or you do not have the correct tools, have a Harley-Davidson dealer perform the installation. Improper installation of this kit could result in death or serious injury. (00333b)

NOTE

This instruction sheet references service manual information. A service manual for your model motorcycle is required for this installation. One is available from a Harley-Davidson dealer.

Kit Contents

See Figure 1 to Figure 4, and Table 1 to Table 4.

NOTE

Installation of this kit by an authorized Harley-Davidson dealer will not impact your limited vehicle warranty.

The kit is intended for High Performance applications only. This engine-related performance kit is legal for sale or use in select countries or regions on pollution controlled motor vehicles. Check with your local Harley-Davidson dealer for compliance requirements in your area.

The partial emissions label contained in this kit is a requirement for emissions regulations for all 50-State models listed in the

*fitment statement. Locate the emissions label on the frame tube below the handlebars. Install the partial label from this kit over the **top portion** of the label on the vehicle.*

REMOVAL

Prepare for Service

1. Disarm security system.
2. Raise the motorcycle.
3. See the service manual. Remove seat.
4. See the service manual. Remove main fuse.

▲ WARNING

When servicing the fuel system, do not smoke or allow open flame or sparks in the vicinity. Gasoline is extremely flammable and highly explosive, which could result in death or serious injury. (00330a)

5. See the service manual. Remove fuel tank.

Remove Engine Components

1. See the service manual. Remove existing air cleaner assembly.
2. See the service manual. Remove existing exhaust system.
3. See the service manual. Disassemble engine top end and cam plate assembly.
4. See the service manual. Remove existing clutch diaphragm spring.

INSTALLATION

Install Engine and Clutch Components

1. See Figure 3. Install new inner cam bearings included in kit.
2. See Figure 1 through Figure 4. See the service manual. Assemble cams to cam plate and engine top end using parts from kit.
3. See the service manual. Install clutch diaphragm spring from kit.
4. **US Models:** See the service manual. Install exhaust system. **Non-US Models:** For required head pipe and muffler see the P&A Retail Catalog or the Parts and Accessories section of www.harley-davidson.com (English only).



5. **US Models:** Install air cleaner assembly. Follow instructions in air cleaner kit. **Non-US Models:** For required air cleaner element and back plate see the P&A Retail Catalog or the Parts and Accessories section of www.harley-davidson.com (English only).

Final Assembly

1. See the service manual. Install fuel tank.
2. See the service manual. Install seat.
3. See the service manual. Install main fuse.

▲ WARNING

After installing seat, pull upward on seat to be sure it is locked in position. While riding, a loose seat can shift causing loss of control, which could result in death or serious injury. (00070b)

Install ACR Overlay Wire Harness (for Applicable Models)

NOTE

Calibrate the ECM before connecting the ACR overlay harness connectors to the ACR solenoids in the cylinder heads.

1. Refer to ACR instruction sheet to install ACR Overlay Wire Harness Kit.

NOTICE

You must recalibrate the ECM when installing this kit. Failure to properly recalibrate the ECM can result in severe engine damage. (00399b)

2. Download the new ECM calibration using the Digital Technician™ at a Harley-Davidson dealer or using a Screamin' Eagle Street Performance Tuner Kit.
3. Run engine. Repeat several times to verify proper operation.

Operation

Refer to BREAK-IN RIDING RULES in the Owner's Manual to break in the motorcycle.

SERVICE PARTS

is08610

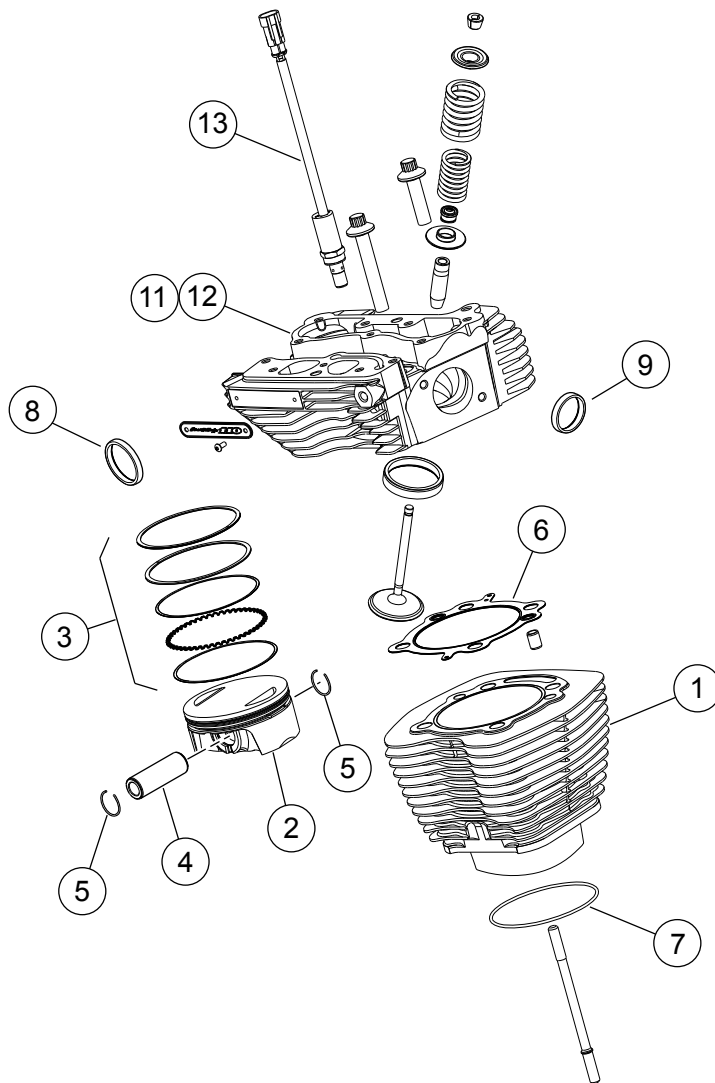

Figure 1. Service Parts: Screamin' Eagle Twin Cam 110 (1800 cc) Conversion Kit Bolt-on Conversion Kit

Table 1. Service Parts: Screamin' Eagle Twin Cam 110 (1800 CC) Conversion Kit

Item	Description (Quantity)	Part Number	Item	Description (Quantity)	Part Number
1	Cylinder assembly (Black) (2)	16800102	8	Gasket, exhaust port (2)	65324-99A
2	Piston (2)	Not Sold Separately	9	Seal, intake manifold (2)	26995-86B
3	Piston Ring Set (2)	21951-11	10	Valve seal (4) (not shown)(not re-quired)	18094-02A
4	Piston pin (2)	22100001	11	Cylinder head, front (black) (includes ACR)	17288-08A
5	Piston pin circlip (4)	22097-99	12	Cylinder head, rear (black) (includes ACR)	17252-07A
6	Gasket, cylinder head (2)	16801-07B	13	Automatic Compression Release (ACR)	28861-07A
7	O-ring, cylinder spigot (2)	11256	Notes: Piston Kit (2100050) includes 2 through 5. Item 6 through 10 are also included in Top End and Cam Gasket Kit (16500385). Refer to 2010 FLHTCUSE5 Parts Catalog (99428-10) for cylinder assembly (11, 12) components.		

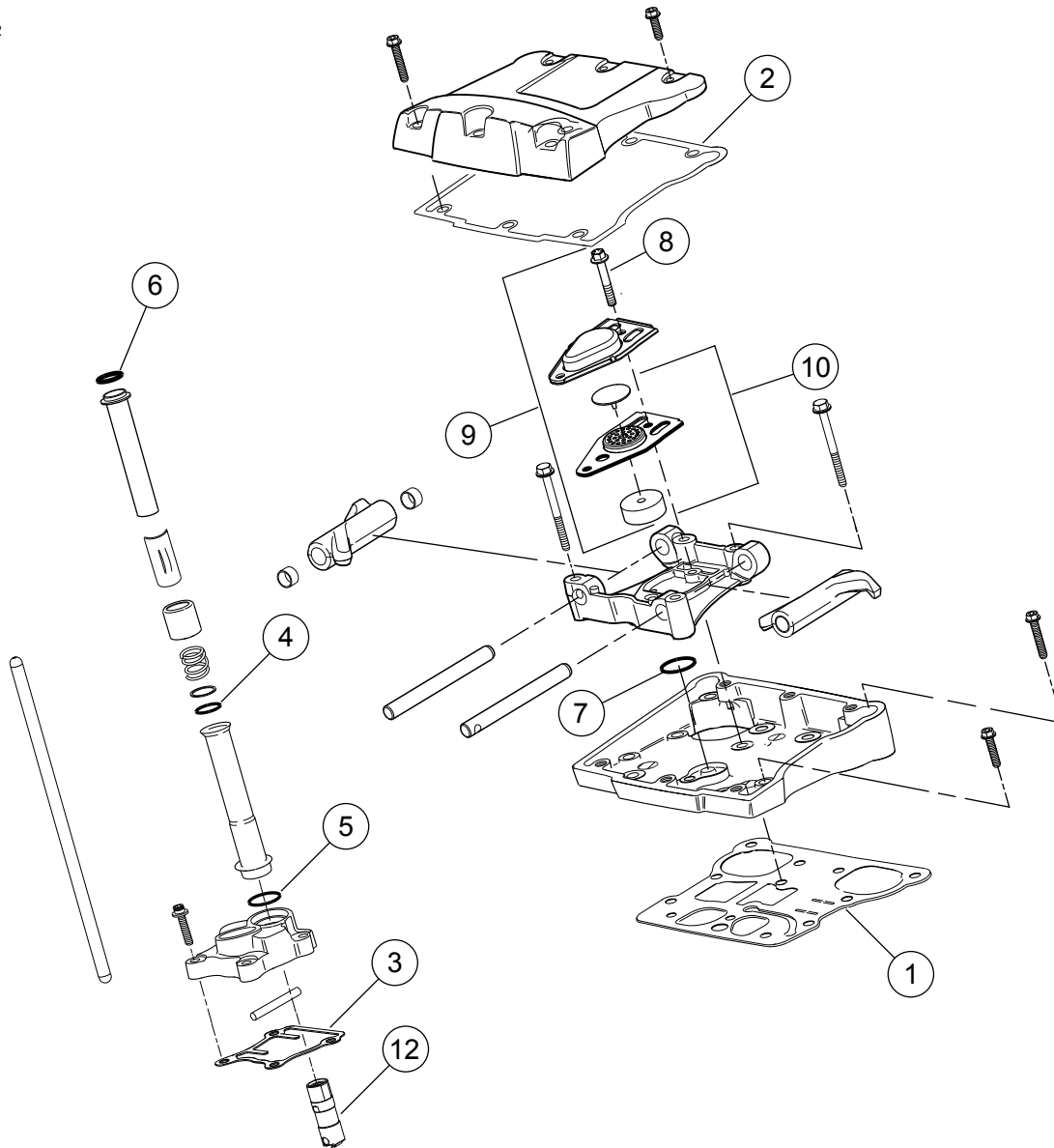

Figure 2. Service Parts: Screamin' Eagle Twin Cam 110 (1800 cc) Bolt-on Conversion Kit

Table 2. Service Parts: Screamin' Eagle Twin Cam 110 bolt-on (1800 CC) Conversion Kit

Item	Description (Quantity)	Part Number	Item	Description (Quantity)	Part Number
1	Gasket, rocker cover base (2)	16719-99B	8	Breather bolt (4)	4400
2	Gasket, rocker cover top (2)	17386-99A	9	Breather assembly (2)	17025-03A
3	Gasket, tappet cover (2)	18635-99B	10	Baffle assembly (2) [includes gaskets (2)]	26500002
4	O-ring, middle push rod cover (4)	11132A	11	Spring, clutch diaphragm (2) (Not Shown)	37951-98
5	O-ring, lower push rod cover (4)	11145A	12	High capacity tappet kit	18572-13

Table 2. Service Parts: Screamin' Eagle Twin Cam 110 bolt-on (1800 CC) Conversion Kit

Item	Description (Quantity)	Part Number	Item	Description (Quantity)	Part Number
6	O-ring, upper push rod cover (4)	11293	Notes: Items 1 through 10 are included in Top End and Cam Gasket Kit (16500385).		
7	O-ring, rocker arm support (2)	11270			

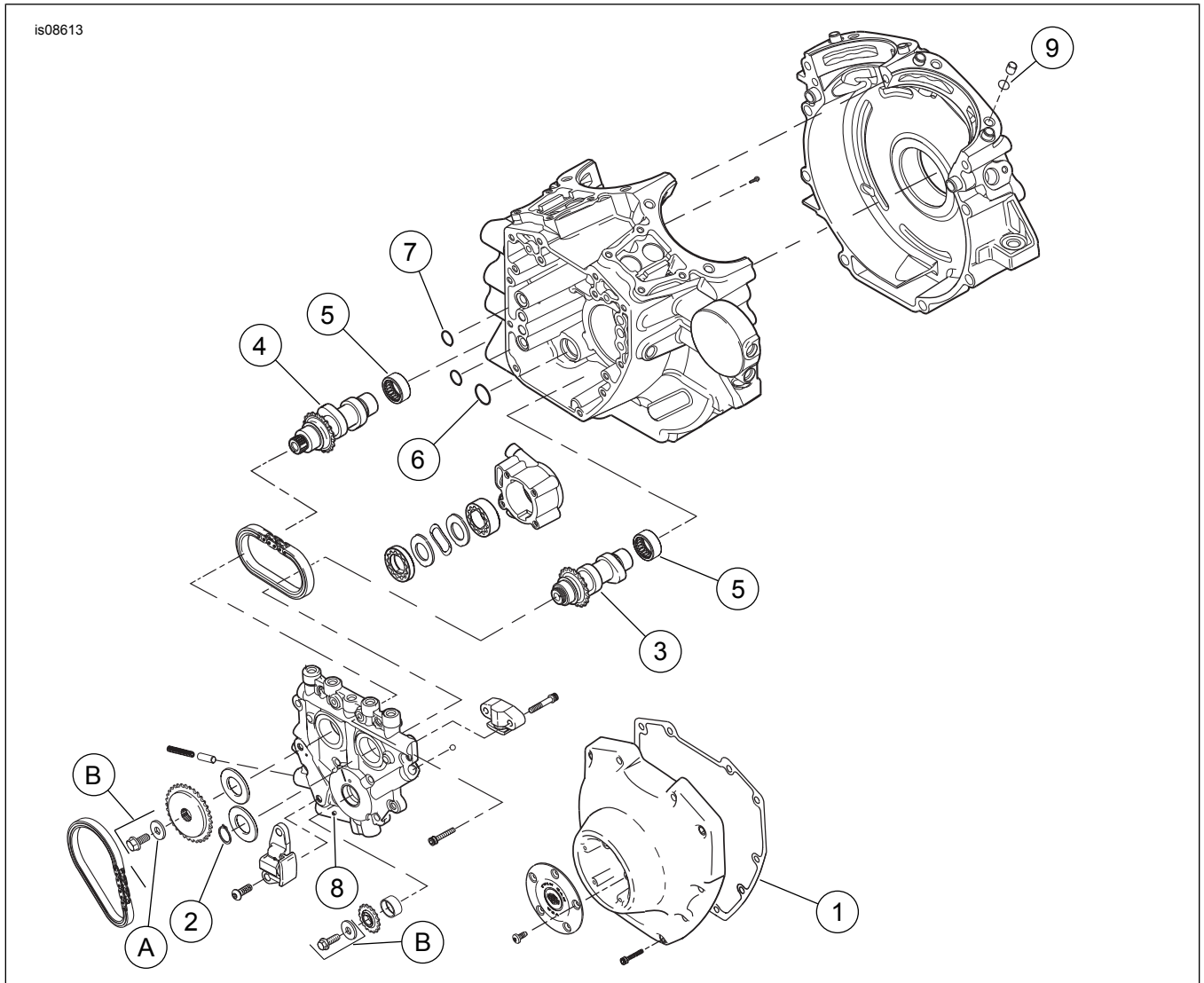

Figure 3. Service Parts: Screamin' Eagle Twin Cam 110 (1800 cc) Bolt-on Conversion Kit

Table 3. Service Parts: Screamin' Eagle Twin Cam 110 (1800 CC) Bolt-on Conversion Kit

Item	Description (Quantity)	Part Number
1	Gasket, cam cover	25244-99A
2	Retaining ring	11461
3	Camshaft, front	Not Sold Separately
4	Camshaft, rear	Not Sold Separately
5	Bearing kit, needle, left side (2)	24018-10
6	O-ring, oil pump to cam plate	11293
7	O-ring, cam plate to crankcase (2)	11301
8	Roll pin	601
9	O-ring, crankcase dowel (2)	11273
Items mentioned in text, but not included in kit:		
A	Washer	6294
B	Cam drive retention kit (includes screw and washer)	25566-06
Items 3 and 4 are available in Cam Kit (25638-07)		
Items 1, 3, and 5 through 9 are included in Top End and Cam Gasket Kit (16500385)		

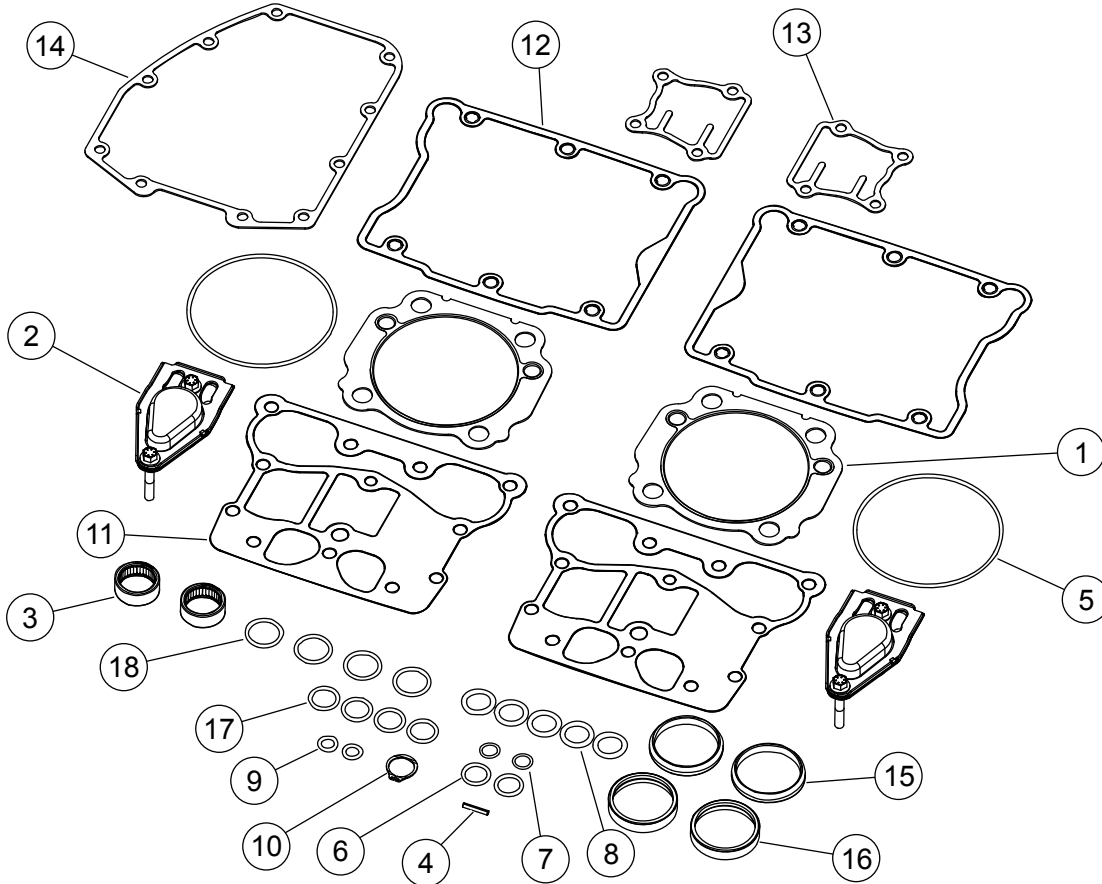

Figure 4. Service Parts: Screamin' Eagle Twin Cam 110 (1800 cc) Bolt-on Conversion Kit

Table 4. Service Parts: Screamin' Eagle Twin Cam 110 (1800 CC) Bolt-on Conversion Kit

Item	Description (Quantity)	Part Number
1	Gasket, cylinder head (2)	16801-07B
2	Breather assembly (2)	17025-03A
3	Bearing kit, needle, left side, camshaft (2)	24018-10
4	roll pin, cam plate pressure relief	601
5	O-ring, cylinder spigot (2)	11256
6	O-ring, rocker arm support (2)	11270
7	O-ring, crankcase dowel (2)	11273
8	O-ring, upper push rod cover (4), oil pump to cam plate (1)	11293
9	O-ring, cam plate to crankcase (2)	11301
10	Retaining ring	11461
11	Gasket, rocker cover base (2)	16719-99B
12	Gasket, rocker cover top (2)	17386-99A
13	Gasket, Tappet cover (2)	18635-99B
14	Gasket, cam cover	25244-99A
15	Seal, intake manifold (2)	26995-86B
16	Gasket, exhaust port (2)	65324-83B
17	O-ring, middle push rod cover (4)	11132A
18	O-ring, lower push rod cover (4)	11145A
Items mentioned in text, but not included in kit:		
A	Valve seal (4) (not shown) (not required)	18094-02A
Items 1, through 18 are included in 4 in Bolt-on Air Colled Top End and Cam Gasket Kit.		