



INSTRUCTIONS

J06039

2014-10-31



PREMIUM SUSPENSION FOR DYNA

GENERAL

Kit Number

54000066

Models

For model fitment information, see the P&A Retail Catalog or the Parts and Accessories section of www.harley-davidson.com (English only).

Installation Requirements

This kit requires LOCTITE® 243 (blue) for proper installation.

⚠ WARNING

Rider and passenger safety depend upon the correct installation of this kit. Use the appropriate service manual procedures. If the procedure is not within your capabilities or you do not have the correct tools, have a Harley-Davidson dealer perform the installation. Improper installation of this kit could result in death or serious injury. (00333b)

NOTE

This instruction sheet references service manual information. A service manual for your model motorcycle is required for this installation. One is available from a Harley-Davidson Dealer.

Kit Contents

See Figure 3 and Table 1.

REMOVAL

NOTE

When removing shocks, remove and replace one shock at a time. This method does not require raising and blocking the rear wheel. To remove both shocks at the same time, place the motorcycle on a center stand with the rear wheel raised off the ground.

1. Remove rear shock absorbers. See the service manual. Retain the hardware for new shock installation.

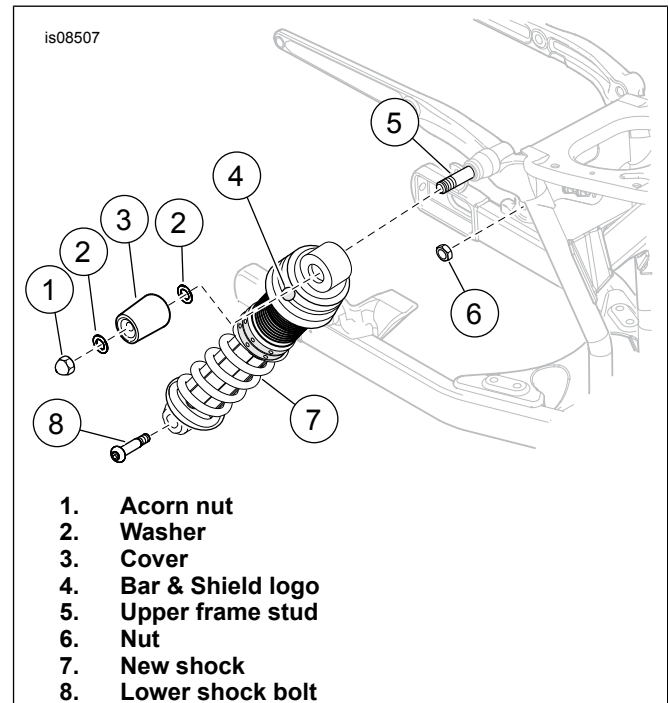

Figure 1. Rear Shock Absorber Installation

INSTALLATION

1. Install upper shock mount to **Both Sides**: See Figure 1. Position the Bar & Shield logo (4) at the top and facing the outboard side. Install upper shock mount to frame:
 - a. Slide the upper shock onto the upper frame stud (5).
 - b. Install washer (2) onto upper frame stud.
 - c. Install cover (3) onto upper frame stud.
 - d. Install washer (2) onto upper frame stud.
 - e. Apply Loctite 243 (blue) to upper frame stud.
 - f. Install acorn nut (1).
2. Install lower shock mount to **Right Side**: Apply Loctite 243 (blue) to lower shock bolt (8). Install bolt. Install lower shock mount to **Left Side**: Apply Loctite 243 (blue) to lower shock bolt (8). Install bolt. Install nut (6).
3. Tighten shock mounting nuts and bolts. Tighten to 40.7–54.2 N·m (30–40 ft-lbs)

SHOCK ABSORBER ADJUSTMENT

⚠ WARNING

Adjust both shock absorbers equally. Improper adjustment can adversely affect stability and handling, which could result in death or serious injury. (00036b)

NOTE

The minimum distance (5 See Figure 2) is 16 mm (0.62 in).
The maximum distance (5 See Figure 2) is 46 mm (1.81 in).

The lock nut is not tight on new shock. The adjustment must be completed and the adjuster nut locked before vehicle operation.

1. Clean the adjuster threads (11).
2. See Figure 2. Loosen adjuster nut and lock nut:
 - a. Place spanner wrench nipple (8) in hole of adjuster nut (1).
 - b. Rotate in direction (10) to separate the two nuts.
3. See Table 2 or Table 3. Determine desired adjuster nut location for the total weight of rider, passenger cargo and accessories.
4. Measure location by placing the bottom of the spanner wrench (4) on the bottom of the cone (3). Read the measurement on the spanner wrench (6) at the top of the adjuster nut. Note measured distance. Rotate adjuster nut to desired location (5).
5. Repeat previous steps on opposite side. Verify that the measured distance is the same for both shocks.
6. Locking adjuster nut and lock nut in position:
 - a. Rotate locknut to touch adjuster nut.
 - b. Place spanner wrench nipple into adjuster nut.
 - c. Rotate in direction (9) to lock nuts together.
 - d. Repeat steps A through C on opposite side.

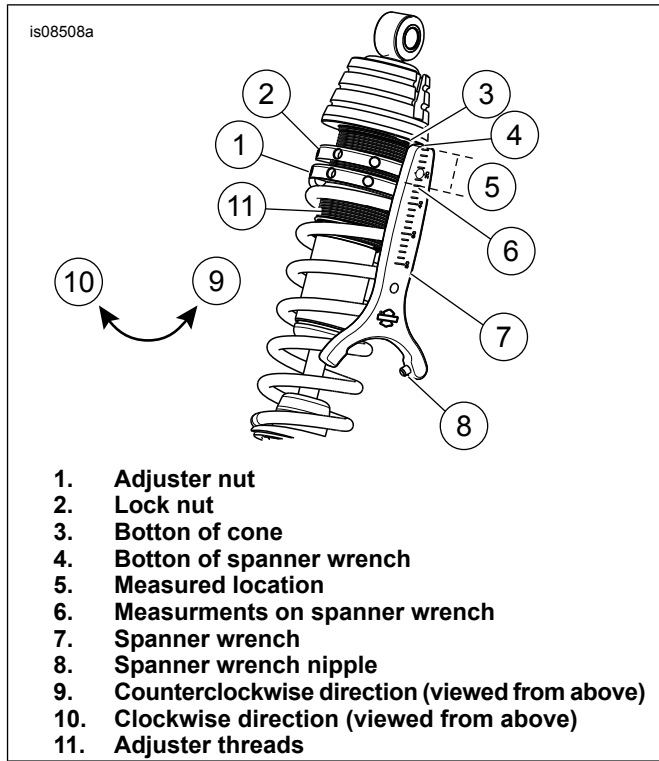

Figure 2. Preload Adjustment

SERVICE PARTS

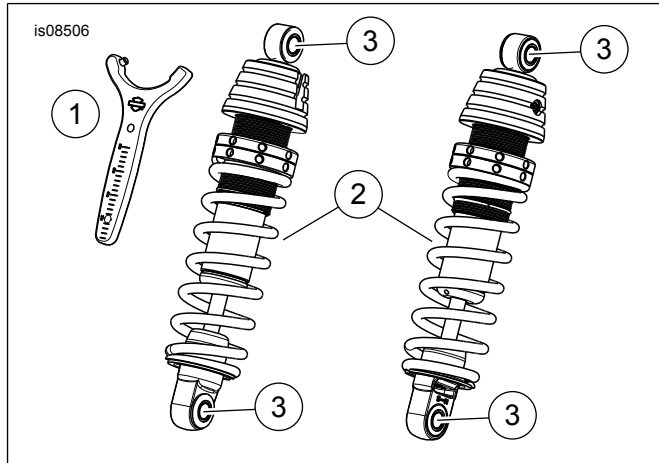

Figure 3. Service Parts: Dyna Rear Shock Kit

Table 1. Service Parts

Item	Description (Quantity)	Part Number
1	Spanner wrench	14900080
2	Shock absorber (2) (includes item 3)	54000067
3	• Bushing (2 per shock)	54556-84

PRELOAD TABLES

Table 2. Manual Suspension Preload Table: FXDF (Only)

		ADDITIONAL WEIGHT OF PASSENGER, CARGO, AND ADDED ACCESSORIES																						
		0	10	20	30	40	50	60	70	80	90	100	110	120	130	140	150	160	170	180	190	200	210	220
	LB	0	10	20	30	40	50	60	70	80	90	100	110	120	130	140	150	160	170	180	190	200	210	220
	KG	0	4.5	9.0	13.6	18.1	22.6	27.2	31.7	36.2	40.8	45.3	49.9	54.4	58.9	63.5	68.0	72.5	77.1	81.6	86.1	90.7	95.2	99.7
		Measurement Between Top of Adjuster Nut and Bottom of Cone (mm)																						

Table 2. Manual Suspension Preload Table: FXDF (Only)

		ADDITIONAL WEIGHT OF PASSENGER, CARGO, AND ADDED ACCESSORIES																							
RIDER WEIGHT	100	45	16	18	19	21	22	23	25	26	27	29	30	31	33	34	35	37	38	39	41	42	43	45	46
	110	50	17	19	20	21	23	24	25	27	28	30	31	32	34	35	36	38	39	40	42	43	44	45	46
	120	54	18	20	21	22	24	25	26	28	29	30	32	33	34	36	37	38	40	41	43	44	45	46	
	130	59	19	21	22	23	25	26	27	29	30	31	33	34	35	37	38	39	41	42	43	45	46		
	140	64	20	21	23	24	26	27	28	30	31	32	34	35	36	38	39	40	42	43	44	45	46		
	150	68	21	22	24	25	26	28	29	30	32	33	35	36	37	39	40	41	43	44	45	46			
	160	73	22	23	25	26	27	29	30	31	33	34	35	37	38	39	41	42	43	45	46				
	170	77	23	24	26	27	28	30	31	32	34	35	36	38	39	40	42	43	44	45	46				
	180	82	24	25	26	28	29	31	32	33	35	36	37	39	40	41	43	44	45	46					
	190	86	25	26	27	29	30	31	33	34	35	37	38	40	41	42	44	45	46						
	200	91	26	27	28	30	31	32	34	35	36	38	39	40	42	43	44	45	46						

Table 3. Manual Suspension Preload Table: All Dyna except FXDF

		ADDITIONAL WEIGHT OF PASSENGER, CARGO, AND ADDED ACCESSORIES																							
	LB	0	10	20	30	40	50	60	70	80	90	100	110	120	130	140	150	160	170	180	190	200	210	220	
	KG	0	4.5	9.0	13.6	18.1	22.6	27.2	31.7	36.2	40.8	45.3	49.9	54.4	58.9	63.5	68.0	72.5	77.1	81.6	86.1	90.7	95.2	99.7	
		Measurement Between Top of Adjuster Nut and Bottom of Cone (mm)																							
RIDER WEIGHT	100	45	16	18	19	21	22	23	25	26	27	29	30	31	33	34	35	37	38	39	41	42	43	45	46
	110	50	17	19	20	21	23	24	25	27	28	30	31	32	34	35	36	38	39	40	42	43	44	45	46
	120	54	18	20	21	22	24	25	26	28	29	30	32	33	34	36	37	38	40	41	43	44	45	46	
	130	59	19	21	22	23	25	26	27	29	30	31	33	34	35	37	38	39	41	42	43	45	46		
	140	64	20	21	23	24	26	27	28	30	31	32	34	35	36	38	39	40	42	43	44	45	46		
	150	68	21	22	24	25	26	28	29	30	32	33	35	36	37	39	40	41	43	44	45	46			
	160	73	22	23	25	26	27	29	30	31	33	34	35	37	38	39	41	42	43	45	46				
	170	77	23	24	26	27	28	30	31	32	34	35	36	38	39	40	42	43	44	45	46				
	180	82	24	25	26	28	29	31	32	33	35	36	37	39	40	41	43	44	45	46					
	190	86	25	26	27	29	30	31	33	34	35	37	38	40	41	42	44	45	46						
	200	91	26	27	28	30	31	32	34	35	36	38	39	40	42	43	44	45	46						
	210	95	27	28	29	31	32	33	35	36	37	39	40	41	43	44	45	46							
	220	100	27	29	30	32	33	34	36	37	38	40	41	42	44	45	46								
	230	104	28	30	31	32	34	35	36	38	39	40	42	43	44	45	46								
	240	108	29	31	32	33	35	36	37	39	40	41	43	44	45	46									
	250	113	30	32	33	34	36	37	38	40	41	42	44	45	46										
	260	117	31	32	34	35	37	38	39	41	42	43	44	45	46										
	270	122	32	33	35	36	37	39	40	41	43	44	45	46											
280	127	33	34	36	37	38	40	41	42	44	45	46													