



INSTRUCTIONS

J06325

2016-05-25



BOOM! AUDIO STAGE II TOUR-PAK AMPLIFIER INSTALLATION KIT

GENERAL

Dealer installation is recommended.

Kit Number

76000751

Models

For model fitment information, see the P&A retail catalog or the Parts and Accessories section of www.harley-davidson.com (English only).

Installation Requirements

This kit must be installed:

- **Before** installation of the Boom! Audio Stage II Tour-Pak Speaker Kit (Part No. 76000526).
- **After** installation of a PRIMARY fairing-mounted amplifier.

The amplifier (Part No. 76000277A) installed **with this kit** must be purchased separately from a Harley-Davidson dealer.

FLHX, FLHXS and FLHXSE models require installation of an original equipment (OE) rigid Tour-Pak Mounting Rack. See a Harley-Davidson dealer for the correct parts, available separately. Install per the service manual.

ALL models: If installing **more than TWO amplifiers**, only **one** AUDIO IN Three-Way Y-Connector (Part No. 69201092) **AND one** Battery+ Three-Way Y-Connector (Part No. 70270-04A) are needed. These connectors could be included in other kits. Purchase separately from a Harley-Davidson dealer as needed.

NOTE

DO NOT mix Stage I and Stage II speakers on the same vehicle.

NOTICE

Radio EQ MUST be updated by a Harley-Davidson dealer BEFORE operating the audio system. Operating the audio system prior to radio EQ update will IMMEDIATELY damage the speakers. (00645d)

Radio EQ update using the Digital Technician® II diagnostic tool is:

- Recommended **before** speaker INSTALLATION
- Required **before** audio system OPERATION.
- Only available through authorized Harley-Davidson dealers.

⚠ WARNING

Rider and passenger safety depend upon the correct installation of this kit. Use the appropriate service manual procedures. If the procedure is not within your capabilities or you do not have the correct tools, have a Harley-Davidson dealer perform the installation. Improper installation of this kit could result in death or serious injury. (00333b)

NOTE

This instruction sheet references service manual information. A service manual for this year/model motorcycle is required for this installation. One is available from a Harley-Davidson dealer.

Electrical Overload

NOTICE

It is possible to overload the vehicle's charging system by adding too many electrical accessories. If the combined electrical accessories operating at any one time consume more electrical current than the vehicle's charging system can produce, the electrical consumption can discharge the battery and cause damage to the vehicle's electrical system. (00211d)

⚠ WARNING

When installing any electrical accessory, be certain not to exceed the maximum amperage rating of the fuse or circuit breaker protecting the affected circuit being modified. Exceeding the maximum amperage can lead to electrical failures, which could result in death or serious injury. (00310a)

The amplifier installed **with this kit** requires up to **8 amps** more current from the electrical system.

Kit Contents

See Figure 9 and Table 1.

PREPARATION

⚠ WARNING

To prevent accidental vehicle start-up, which could cause death or serious injury, remove main fuse before proceeding. (00251b)

1. See the service manual to perform the following generalized steps:



2. See the service manual to perform the following generalized steps:
 - a. Remove seat. Retain all seat mounting hardware.
 - b. Remove the ECM caddy from the top of the battery.
 - c. Disconnect both battery cables, negative battery cable first.
 - d. Remove battery.
 - e. Remove right side cover.
 - f. Remove left side cover.
 - g. Remove the two bolts attaching the electrical caddy under the left side cover.

AMPLIFIER INSTALLATION

1. Clean the capacity label inside the Tour-Pak with a 50-50 mixture of isopropyl alcohol and distilled water. See Figure 9. Apply the **new** load limit label (2) covering the original label. Note the revised load limit due to the amplifier installation.
2. Install the brackets (4 and 8) to amplifier (A) with screws (6). Alternately tighten to 9.5–12.2 N·m (84–108 **in-lbs**).
3. Remove all items from Tour-Pak®. Remove Tour-Pak. Remove Tour-Pak liner (if present). Place Tour-Pak on a protected surface.

NOTE

- *Disconnect speakers. Remove speakers from speaker pods to avoid damage to wiring inside.*
- *Note wire locations in connectors. To aid in drilling, de-pin both connector halves. Pull wires away from drilling area.*
- *Use of a step drill bit is recommended to prevent damage to the speaker pod covering.*

4. See Figure 1. Drill a **new** 25 mm (1.0 in) hole (3) in each speaker pod (1), away from the existing grommet (2), approximately where shown.

NOTE

These holes are for leads [36TB] and [37TB] of the amplifier harness (Figure 9, Item 3), which connect during installation of the Boom! Audio Stage II Tour-Pak Speaker Kit.

5. Lightly sand the speaker housings around the grommet holes.
6. Pull wires back through holes. Repin connectors.

NOTE

*If the amplifier is installed **before** the Tour-Pak is mounted, it is not possible to secure the Tour-Pak.*

7. See Figure 2. Place hex nuts (1) into hex pockets (3) on the Tour-Pak support (5).
8. Install Tour-Pak. See the service manual. Tighten screws to 6.8–8.1 N·m (60–72 **in-lbs**).

9. Cover the rear fender with a towel. Slide the amplifier with brackets in from the side.
10. Install the amplifier. Secure with flat washers (7), lockwashers (8) and screws (6). Tighten screws to 6.8–8.1 N·m (60–72 **in-lbs**).

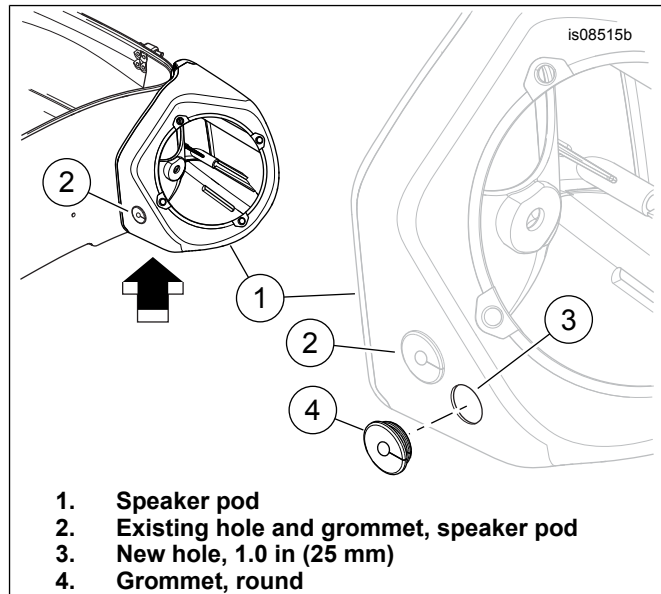

Figure 1. Grommet Installation

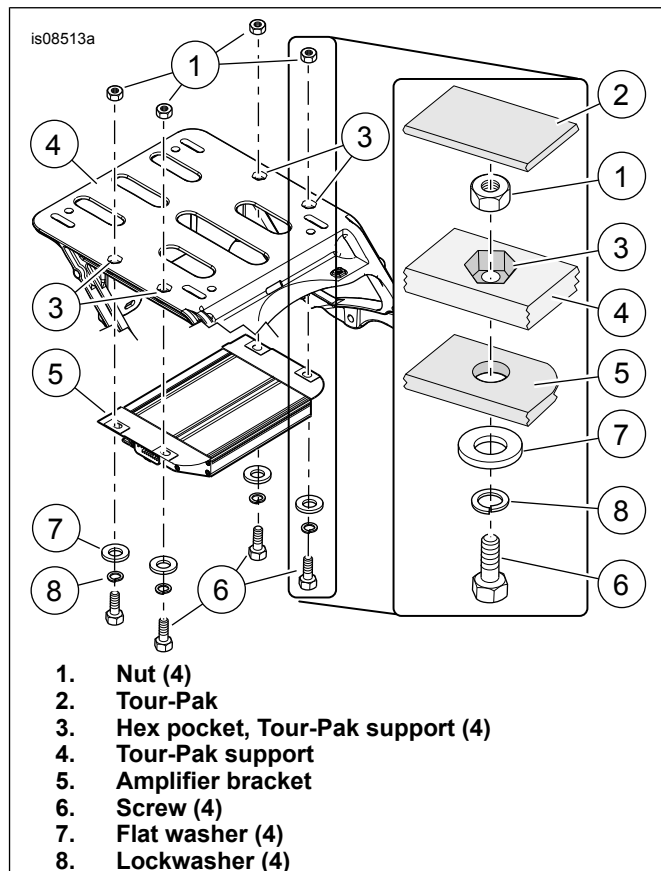

Figure 2. Amplifier Installation

AMPLIFIER HARNESS INSTALLATION

NOTE

These tips help make sure all wiring fits under the seat, especially in multiple amplifier installations:

- See Figure 5. Begin routing the amplifier harness from the large 23-way connector [149] (1), moving forward on the vehicle. The large connector **does not fit** through narrower passages.
- Route the remainder of the harness forward on the vehicle through the space between the Tour-Pak support (3) and fender (4).
- Route all wire harnesses **under** the frame rail to avoid pinching by cover or seat.
- Make connections [36TB] (right pod speaker) and [37TB] (left pod speaker) during installation of the Boom! Audio Stage II Tour-Pak Speaker Kit.
- Take care to route ALL amplifier harness branches away from spark plug wires. Close proximity induces spark noise into the audio system.
- When routing wires from right to left sides of the vehicle, tuck harnesses **under** the frame tray **behind** the battery. Keep the battery compartment accessible.
- Route the six-way black, pink-wired audio connectors **under** the right frame rail, into the right side cover. Bundle in front of ABS module, if present.
- Locate the black, four-way Molex connector [296A] near the back of the underseat area. **FLHX/FLTRX models:** On a jumper harness coming from the fairing. **FLHTCU/FLHTK models:** On an adapter harness with two 16-way ([162C] and [162D]) and two four-way ([296A] and [297B]) connectors. **With ONLY ONE Stage II amplifier installed in the rear:** Remove the plug in the [296A] connector. Connect the amplifier harness. **With TWO or more Stage II amplifiers installed in the rear:** Plug the audio input harness into connector halves [296A] and [297B] on the interconnect harness (2). Plug amplifier harness (3) connector [296A] into the audio input harness.
- Confirm that the amplifier harness connectors and harness routing are clear of all moving parts.
- Route the battery terminal branch to the battery terminals, but **DO NOT** connect the battery cables now.
- If more than two amplifiers or other accessories already use the ground post of the battery, use one of the frame ground studs.
- If more than two amplifiers are installed on the vehicle, **ONE Battery+ Three-Way Y-Connector** (available separately) is required.
- Once routing is finalized, secure with cable straps (10) and retainers (1).

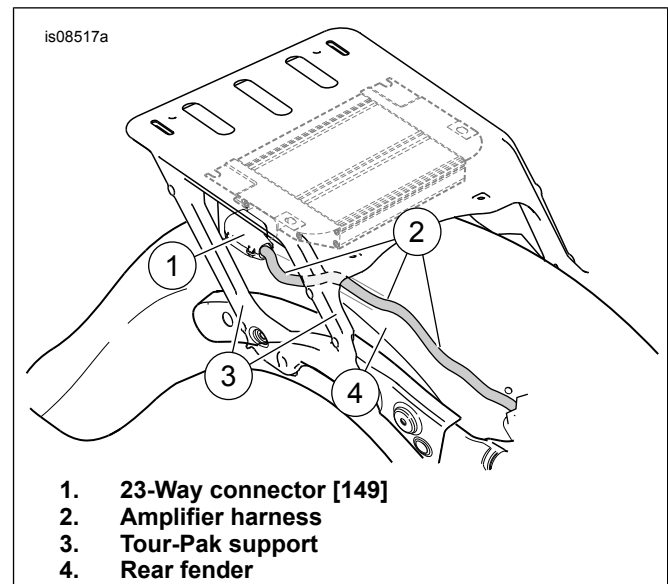

Figure 3. Harness Routing

1. Complete Routing harness:
 - a. Route kit harness forward along frame rails following main harness under backbone.
 - b. Route harness along the right side of battery cavity between the battery and reverse solenoid. Place the red fuse wire and black ground wire in front of the battery.
 - c. See Figure 4. Locate the 2-way Delphi CAN connector [319B] (1) under the right side cover.
 - d. The cap is a terminating resistor pack secured to the electrical caddy. Remove connector [319B] from the resistor pack.
 - e. Connect [319A] from the harness provided with the kit (See Figure 5 item 8) to [319B] of the vehicle.
 - f. If this is the only (rear) amplifier connection in this installation, connect the [319B] side of the harness (See Figure 5 item 9) from the kit back into the terminating resistor pack from step "B" above. If multiple rear amplifiers are used, daisy chain [319B] from this harness to [319A] of the next amplifier harness. Always verify that the remaining connector [319B] is connected to the terminating resistor of the vehicle.
2.
 - a. Locate connector 299 on the vehicle (under the inner fairing, see service manual for location). This connector may already be connected to a fairing amplifier.
 - b. Install 69200921 "Y" (See Figure 7) to vehicle side 299, with one end to the fairing amplifier harness.
 - c. Install the 69201545 (See Figure 6) jumper to the other end of the 69200921 "Y" inside the fairing. (If a 69201545 jumper has already been installed on vehicle skip ahead to "e" Do not install more than one 69201545 jumper.)

- d. Route the 69201545 jumper through the inner fairing and into the wire trough following the fairing harness routing.
- e. Locate the end of the 69201545 jumper under the RH side cover near the [319] connectors. If a 69201545 is present from a prior install use a 69200921 "Y" under the RH side cover to connect [299].

NOTE

If more than one amplifier is installed in rear of vehicle, up to two 69200921 connectors may be used.

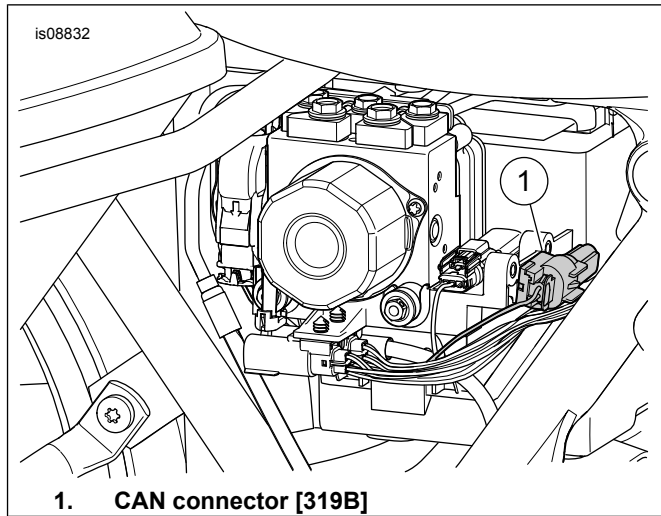

1. CAN connector [319B]

Figure 4. CAN Connector [319B], Under Right Side Cover

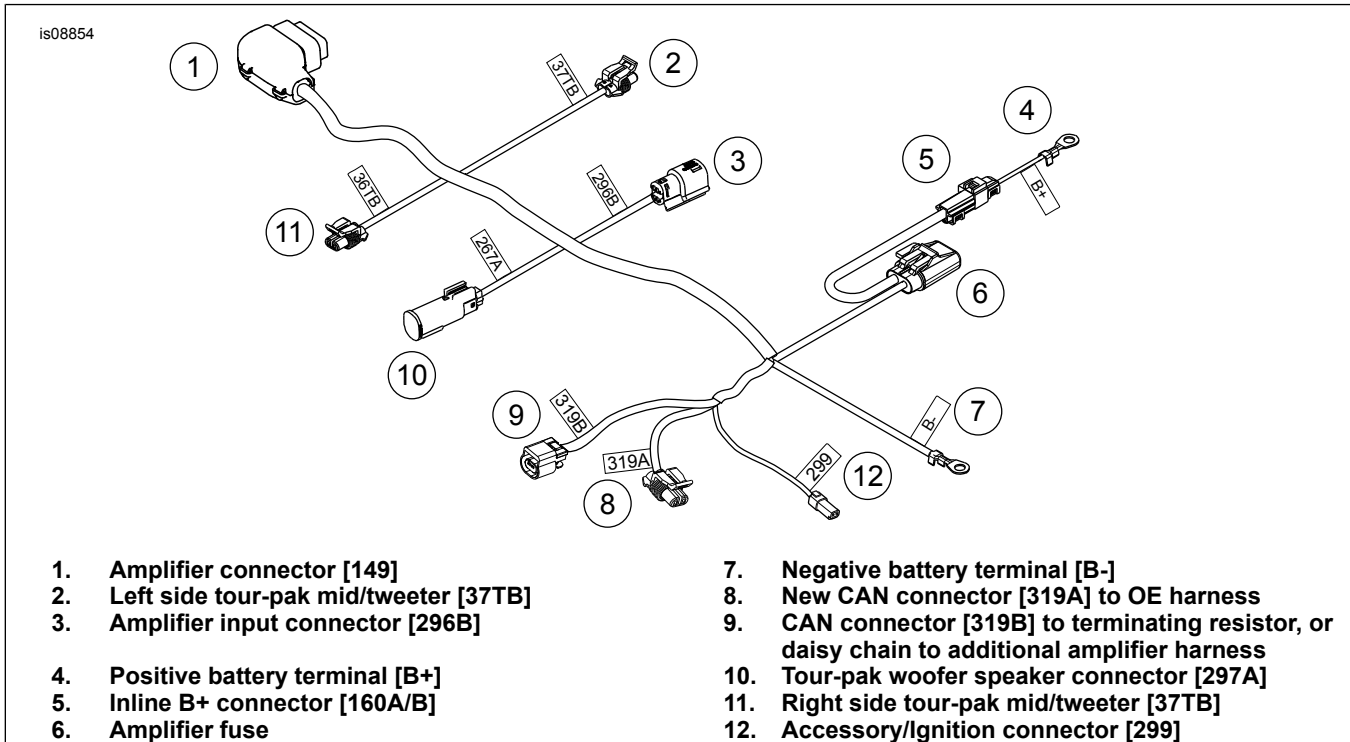

- | | |
|--|---|
| <ul style="list-style-type: none"> 1. Amplifier connector [149] 2. Left side tour-pak mid/tweeter [37TB] 3. Amplifier input connector [296B] 4. Positive battery terminal [B+] 5. Inline B+ connector [160A/B] 6. Amplifier fuse | <ul style="list-style-type: none"> 7. Negative battery terminal [B-] 8. New CAN connector [319A] to OE harness 9. CAN connector [319B] to terminating resistor, or daisy chain to additional amplifier harness 10. Tour-pak woofer speaker connector [297A] 11. Right side tour-pak mid/tweeter [37TB] 12. Accessory/ignition connector [299] |
|--|---|

Figure 5. Main Amplifier Harness

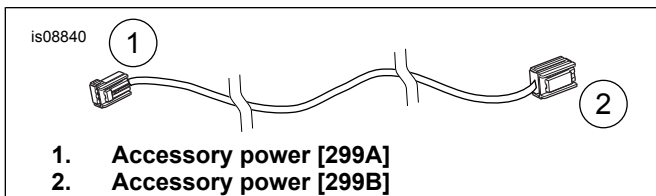
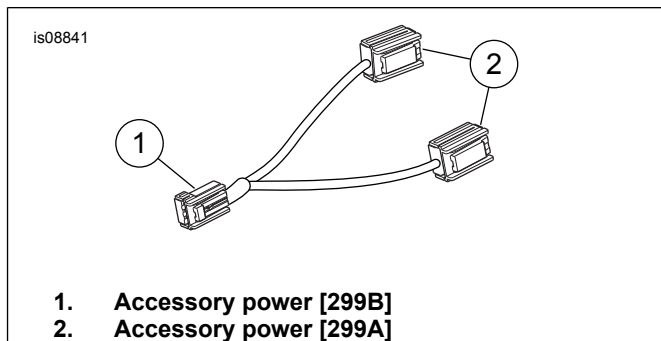
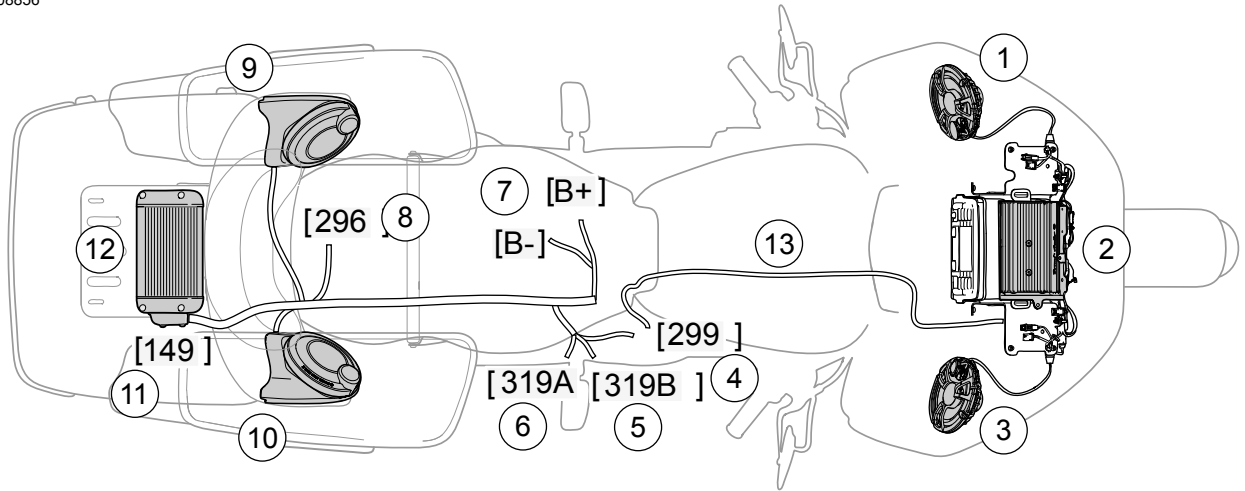

Figure 6. Wire Harness, Jumper



- 1. Accessory power [299B]
- 2. Accessory power [299A]

Figure 7. Accessory Power Wire Harness



- | | |
|---|--|
| 1. Left fairing speaker (may be installed) | 8. Amplifier input connector [296B] |
| 2. Amplifier, fairing, powers fairing speakers, amplifier number 1 (installed earlier) | 9. Left Tour-Pak speaker (installed using this kit) |
| 3. Right fairing speaker (installed earlier) | 10. Right Tour-Pak speaker (installed using this kit) |
| 4. Accessory/Ignition connector [299] | 11. Amplifier connector [149] |
| 5. CAN connector [319B] to terminating resistor, or daisy chain to additional amplifier harness | 12. Amplifier, Tour-Pak, powers Tour-Pak speakers, amplifier number 4 (installed using this kit) |
| 6. New CAN connector [319A] to OE harness | 13. Jumper harness (part number 6901545) |
| 7. Connection to battery [B+ and B-] | |

Figure 8. Speaker Stage II Boom! Audio Tour-Pak Amplifier Installation Kit

COMPLETION

NOTE

To prevent possible damage to the sound system, verify that the ignition switch is **OFF** before attaching the battery cables.

▲ WARNING

Connect positive (+) battery cable first. If positive (+) cable should contact ground with negative (-) cable connected, the resulting sparks can cause a battery explosion, which could result in death or serious injury. (00068a)

1. Install battery. See the service manual.
2. See the service manual. Connect the battery terminal branch to the battery terminals (red positive cable first).
 - a. Position the + ring terminal onto the positive battery terminal. Install the bolt.
 - b. Position the in-line fuse holder in a location that can be easily accessed.
 - c. Position the - ring terminal onto the negative battery terminal. Install the bolt.
 - d. Tighten both bolts to 6.8–7.9 N·m (60–70 in-lbs).
3. Install the electrical caddy under the left side cover with the two bolts removed earlier. Tighten both bolts to 8.1–10.8 N·m (72–96 in-lbs).
4. Install the ECM caddy per the service manual.
5. Apply a light coat of petroleum jelly or corrosion retardant material to battery terminals.
6. See the service manual. Install seat. After installing seat, pull up on the seat to verify that it is secure.
7. See the service manual. Install main fuse.

SERVICE PARTS

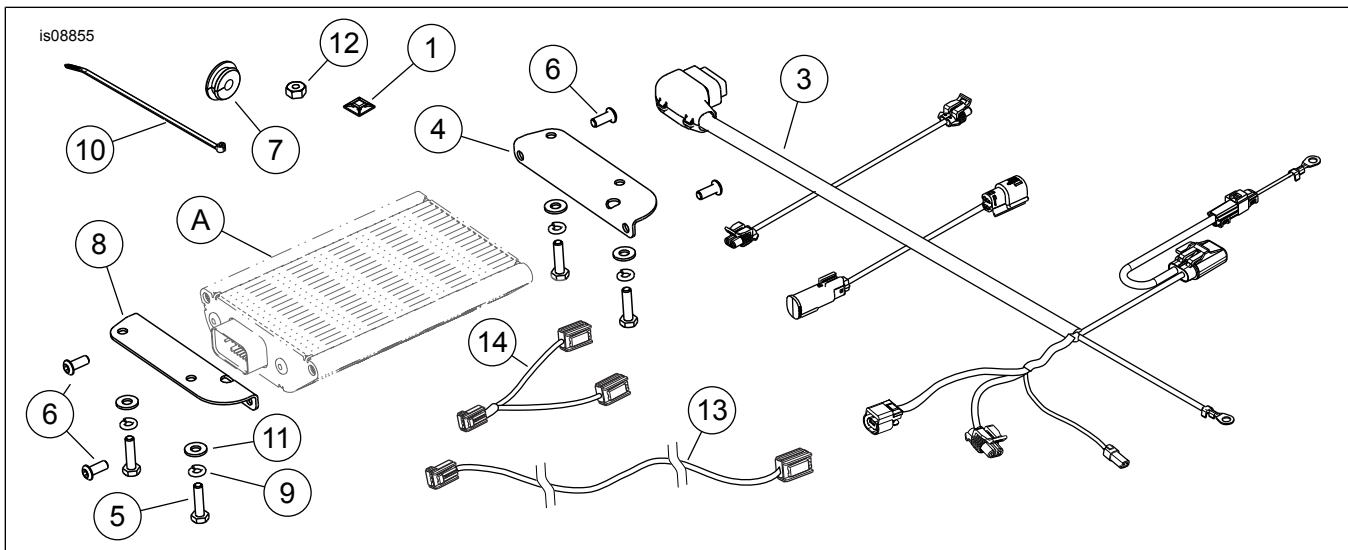

Figure 9. Service Parts, Amplifier Installation Kit

Table 1. Service Parts

Item	Description (Quantity)	Part Number
1	Bracket, wire retainer (4)	69200342
2	Capacity label (not shown)	14001001
3	Wire harness, Tour-Pak Amplifier	Not sold separately
4	Amplifier bracket, left side	Not sold separately
5	Capscrew (4)	2551W
6	Screw (4)	926
7	Grommet, round (2)	12100073
8	Amplifier bracket, right side	Not sold separately
9	Lockwasher (4)	7036
10	Cable strap (6)	10006
11	Flatwasher (4)	6703
12	Nut (4)	10100065
13	Jumper harness	96201545
14	Power Connector	69200921

Item mentioned in text, but not included in kit:

A	Amplifier
---	-----------

Wiring Diagram Information

Wire Color Codes

For Solid Color Wires: See Connector/Wiring Diagram Symbols (Typical) . The alpha code identifies wire color.

For Striped Wires: The code is written with a slash (/) between the solid color code and the stripe code. For example, a trace labeled GN/Y is a green wire with a yellow stripe.

Wiring Diagram Symbols

See Connector/Wiring Diagram Symbols (Typical) . Brackets [] indicate connector numbers. The letter inside the brackets identifies whether the housing is a socket or pin housing.

A=Pin: The letter A and the pin symbol after a connector number identifies the pin side of the terminal connectors.

B=Socket: The letter B and the socket symbol after a connector number identifies the socket side of the terminal connectors. Other symbols found on the wiring diagrams include the following:

Diode: The diode allows current flow in one direction only in a circuit.

Wire break: The wire breaks are used to show option variances or page breaks.

No Connection: Two wires crossing over each other in a wiring diagram that are shown with no splice indicating they are not connected together.

Circuit to/from: This symbol indicates a complete circuit diagram on another page. The symbol is also identifying the direction of current flow.

Splice: Splices are where two or more wires are connected together along a wiring diagram. The indication of a splice only indicates that wires are spliced to that circuit. It is not the true location of the splice in the wiring harness.

Ground: Grounds can be classified as either clean or dirty grounds. Clean grounds are identified by a (BK/GN) wire and are normally used for sensors or modules.

NOTE

Clean grounds usually do not have electric motors, coils or anything that may cause electrical interference on the ground circuit.

Dirty grounds are identified by a (BK) wire and are used for components that are not as sensitive to electrical interference.

Twisted pair: This symbol indicates that the two wires are twisted together in the harness. This minimizes the circuit's electromagnetic interference from external sources. If repairs are necessary to these wires, they should remain as twisted wires.

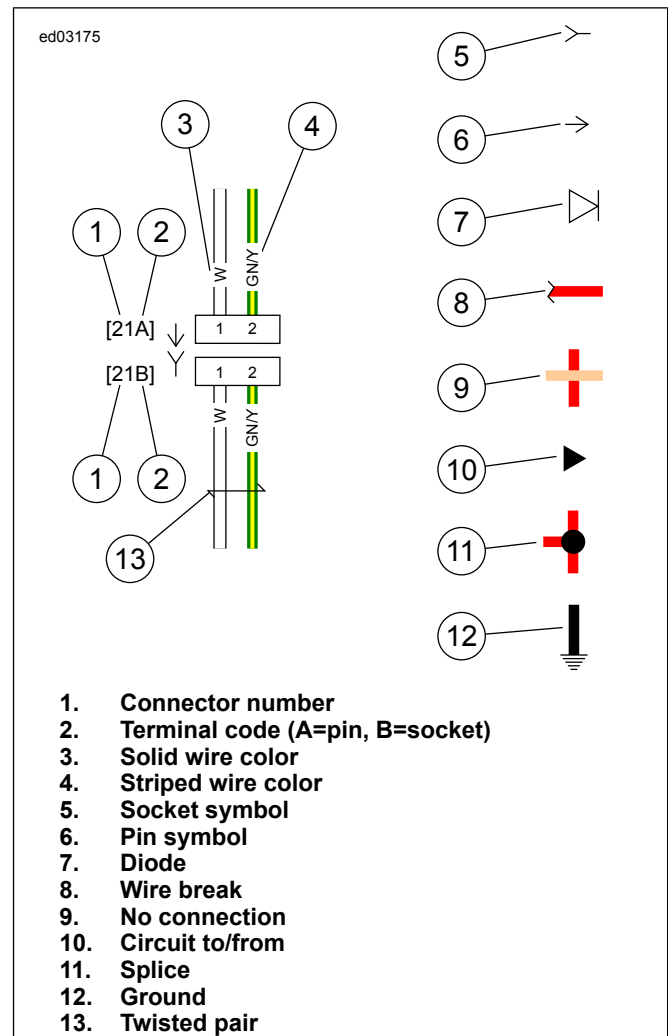
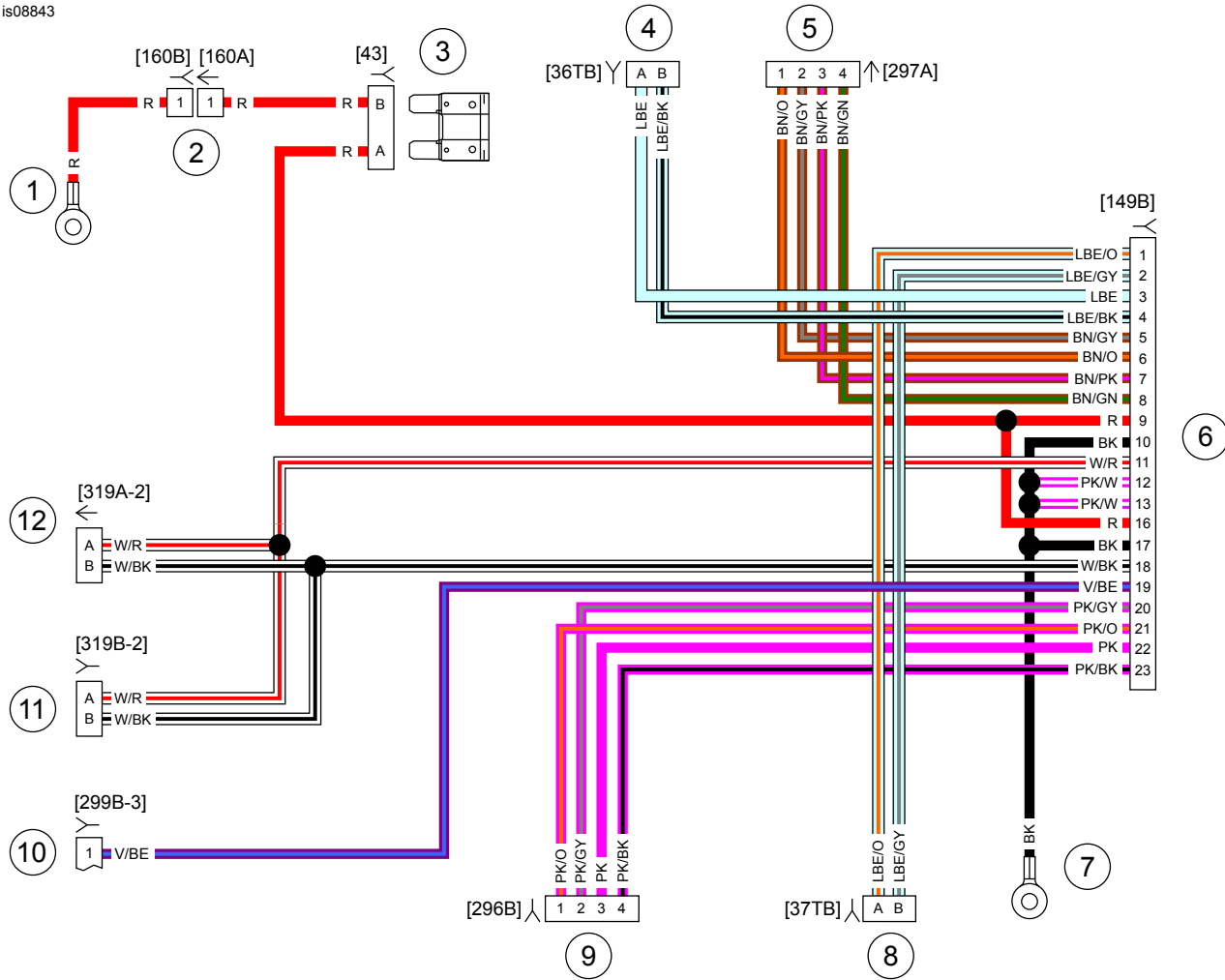

Figure 10. Connector/Wiring Diagram Symbols

Table 2. Wire Color Codes

ALPHA CODE	WIRE COLOR
BE	Blue
BK	Black
BN	Brown
GN	Green
GY	Gray
LBE	Light Blue
LGN	Light Green
O	Orange
PK	Pink
R	Red
TN	Tan
V	Violet
W	White
Y	Yellow



1. Positive ring terminal [B+]
2. Inline B+ connector [160A/B]
3. Amplifier fuse
4. Right side speaker (mid/tweeter) connector [36TB]
5. Rear speaker pod waffer [297A]
6. Fairing amplifier connector [149B]
7. Negative ring terminal [B-]
8. Left side speaker (mid/tweeter) connector [37TB]
9. Amplifier input [296B]
10. Accessory/ignition power [299B]
11. CAN connector [319B]
12. CAN connector [319A]

Figure 11. Main Amplifier Wiring Harness (Fairing)



1. Accessory/Power [299B]
2. Accessory/Power [299A]

Figure 12. Rear Jumper Wire Harness

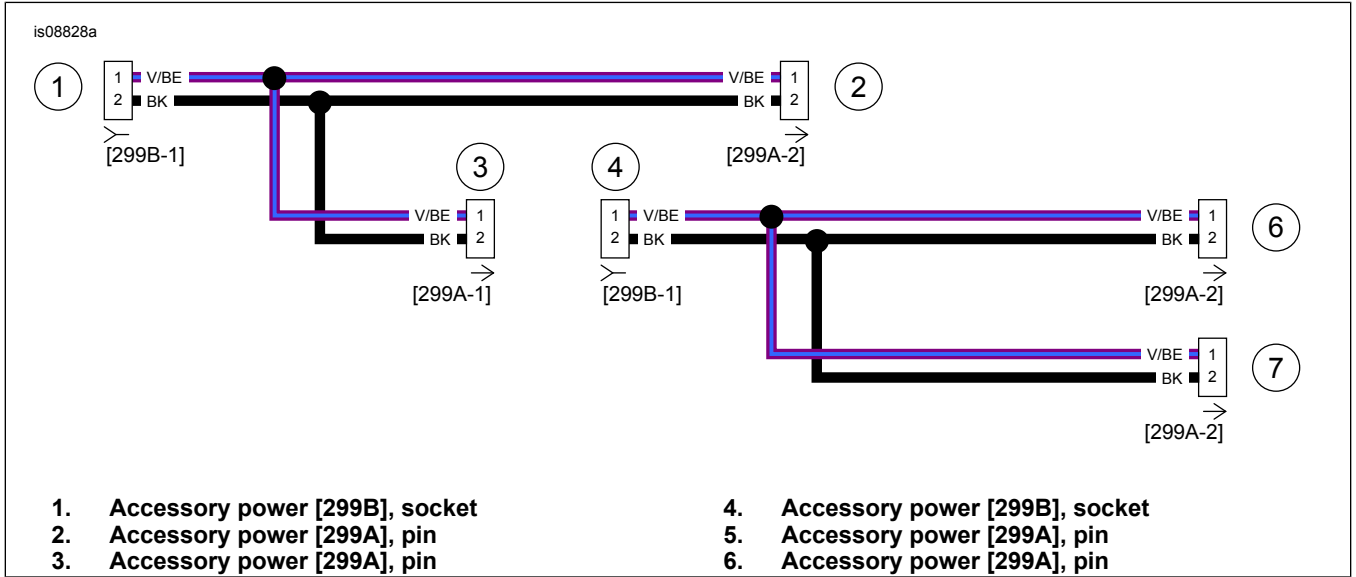

Figure 13. Accessory Power Harness