



INSTRUCTIONS

J06043

2016-09-01



PREMIUM SUSPENSION FOR XL - MEDIUM

GENERAL

Kit Number

54000077

Models

For model fitment information, see the P&A Retail Catalog or the Parts and Accessories section of www.harley-davidson.com (English only).

Installation Requirements

This kit requires LOCTITE® 243 (blue) for proper installation.

▲ WARNING

Rider and passenger safety depend upon the correct installation of this kit. Use the appropriate service manual procedures. If the procedure is not within your capabilities or you do not have the correct tools, have a Harley-Davidson dealer perform the installation. Improper installation of this kit could result in death or serious injury. (00333b)

NOTE

This instruction sheet references service manual information. A service manual for this year/model motorcycle is required for this installation. One is available from a Harley-Davidson dealer.

Kit Contents

See Figure 2 and Table 1.

REMOVAL

NOTE

When removing shocks, remove and replace one shock at a time. This method does not require raising and blocking the rear wheel. To remove both shocks at the same time, place the motorcycle on a center stand with the rear wheel raised off the ground.

1. See the service manual. Remove rear shock absorbers. Retain the nuts and washers for new shock installation.

INSTALLATION

1. See Figure 1. Loosely install upper shock mounting bolt (3) to **Both Sides**: Position the bushing (2) facing the inboard side. Install upper shock eye to frame:
2. Install lower shock eye to **Right Side** (except Japan models):
 - a. Verify bushing (2) is toward vehicle.

- b. Slide lower mounting bolt (7) through washer (8) and bottom shock eye.
- c. Slide lower mounting bolt through rear fork.
- d. Slide lower mounting bolt through one special washer (6).
- e. Slide lower mounting bolt through the belt guard.
- f. Slide lower mounting bolt through one special washer (6).
- g. Apply Loctite 243 (blue) to lower shock bolt. Install nut (4).
- h. Tighten shock mounting bolt and nut.
Torque: 61–68 N·m (45–50 ft-lbs) *Nut (4), bolt (7)*

3.

NOTE

The lower right side mounting bolt on Japan models must be inserted from inside the rear fork (Opposite of what is shown in Figure 1). Removal and installation of rear wheel is needed for this step.

Install lower shock eye to **right side** (Japan only models):

- a. See the service manual. Remove rear wheel.
 - b. Verify bushing (2) is toward vehicle.
 - c. Slide lower mounting bolt (7) through one special washer (6).
 - d. Slide lower mounting bolt through the belt guard.
 - e. Slide lower mounting bolt through one special washer (6).
 - f. Slide lower mounting bolt through rear fork.
 - g. Slide lower mounting bolt through bottom shock eye and washer (8).
 - h. Apply Loctite 243 (blue) to lower shock bolt. Install nut (4).
 - i. Tighten shock mounting bolt and nut.
Torque: 61–68 N·m (45–50 ft-lbs) *Nut (4), bolt (7)*
 - j. See the service manual. Install rear wheel.
4. Remove upper shock bolt. Apply Loctite 243 (blue) to upper shock bolt.
 5. Slide upper mounting bolt (3) through washer (9) and upper shock eye.



6. Slide upper mounting bolt into frame boss.
7. Tighten shock mounting bolt.
Torque: 61–68 N·m (45–50 ft-lbs) *Bolt (3)*
8. Install lower shock mount to **Left Side**:
 - a. Verify bushing (2) is toward vehicle.
 - b. Slide lower mounting bolt (5) through washer (8) and bottom shock eye.
 - c. Slide lower mounting bolt through rear fork.
 - d. Apply Loctite 243 (blue) to lower shock bolt. Install nut (4).
 - e. Tighten shock mounting bolt and nut.
Torque: 61–68 N·m (45–50 ft-lbs) *Nut (4), bolt (5)*
9. Remove upper shock bolt. Apply Loctite 243 (blue) to upper shock bolt.
10. Slide upper mounting bolt (3) through washer (9) and upper shock eye.
11. Slide upper mounting bolt into frame boss.
12. Tighten shock mounting bolt.
Torque: 61–68 N·m (45–50 ft-lbs) *Bolt (3)*

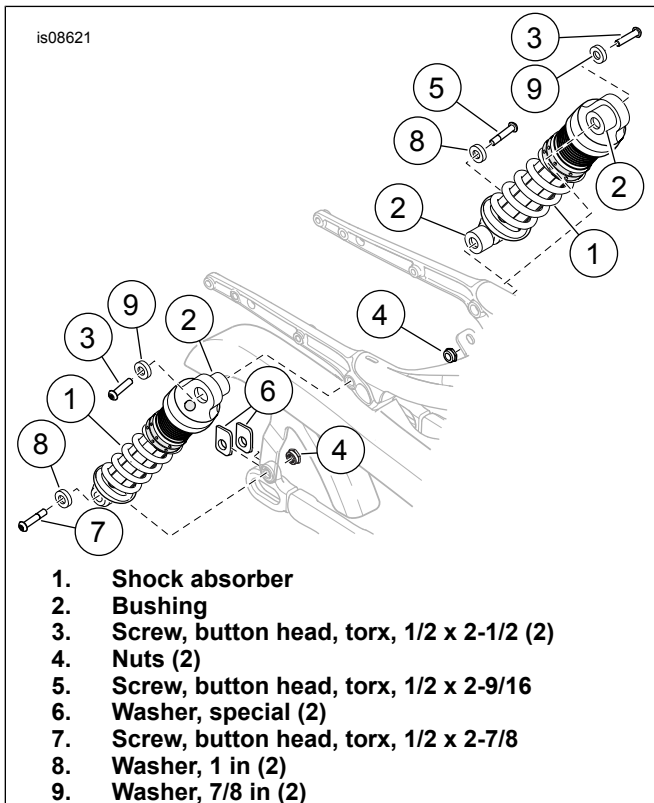

Figure 1. Rear Shock Absorber Installation

SERVICE PARTS

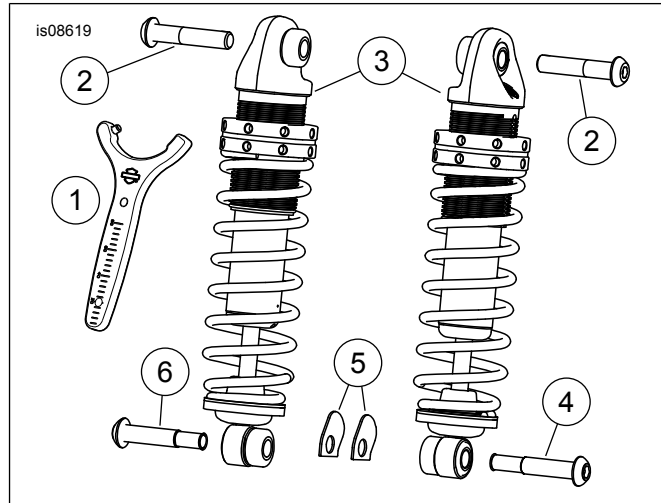

Figure 2. Service Parts: XL Rear Shock Kit

Table 1. Service Parts

Item	Description (Quantity)	Part Number
1	Spanner wrench	14900080
2	Screw, button head, Torx, 1/2 x 2-1/2 (2)	10200392
3	Shock absorber (2)	54000087
4	Screw, button head, Torx, 1/2 x 2-7/8 (1)	10200445
5	Washer, special (2)	10600039
6	Screw, button head, Torx, 1/2 x 2-9/16 (1)	4354

SHOCK ABSORBER ADJUSTMENT

⚠ WARNING

Adjust both shock absorbers equally. Improper adjustment can adversely affect stability and handling, which could result in death or serious injury. (00036b)

NOTE

The locknut is not tight on new shock. The adjustment must be completed and the adjuster nut locked before vehicle operation.

NOTE

To prevent damage to the adjustment and locking rings, do not use any other wrench than the one supplied with this kit.

NOTICE

Avoid shock damage. Make sure shock threads are clean and free of debris before loosening or tightening shock adjusting nuts. (00646b)

1. See Table 2. Determine desired upper locking ring location for the total weight of rider, passenger cargo and accessories.
2. Clean the adjuster threads.
3. See Figure 3. Use the spanner wrench to turn the upper locking ring counterclockwise (1) to unlock the ring:

NOTE

Count down from the top of the shock to locate the recommended preload dot.

4. Use the spanner wrench to turn (2) the lower adjustment ring below the recommended dot.

5. Rotate the upper locking ring to align with the recommended preload dot (3).
6. Cover one-half the recommended preload dot (4) with the upper locking ring.
7. Use the wrench to hand tighten the lower adjustment ring against the locking ring (5).
8. Repeat Shock Absorber Adjustment steps on other side.
9. Verify that both shocks are adjusted evenly.

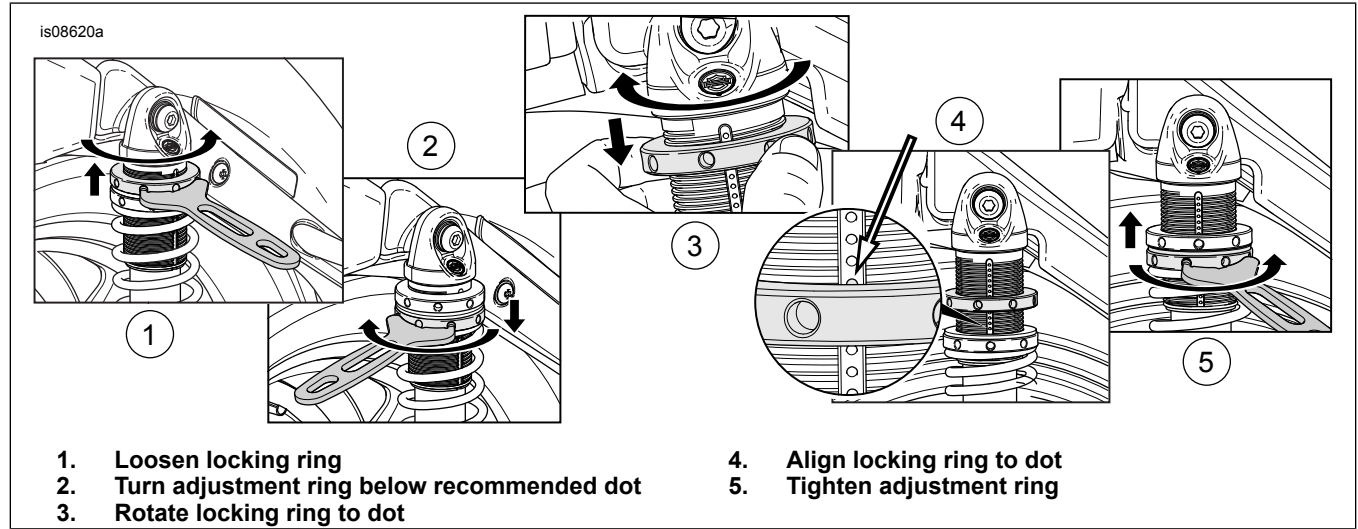

Figure 3. Preload Adjustment

Table 2. Medium Travel Shocks Preload

		WEIGHT OF PASSENGER, CARGO AND ACCESSORIES															
		0	16	32	48	64	80	96	112	128	144	160	176	192	208	224	240
RIDER WEIGHT		PRELOAD DOT															
lb	kg																
100-123	45.4-55.8	1	2	3	4	5	6	7	7	8	9	9	10	11	11	12	13
124-147	56.2-66.7	2	3	4	5	6	7	7	8	9	9	10	11	11	12	13	13
148-171	67.1-77.6	3	4	5	6	7	8	8	9	9	10	11	11	12	13	13	-
172-195	78.0-88.5	4	5	6	7	8	8	9	10	10	11	12	12	13	13	-	-
196-219	88.9-99.3	5	6	7	8	8	9	10	10	11	12	12	13	13	-	-	-