



# INSTRUCTIONS

J05945

2014-10-15



## FRONT DIRECTIONAL LIGHT RELOCATION KIT - XL1200X

### GENERAL

#### Kit Number

67800452, 67800489

#### Models

For model fitment information, see the P&A Retail Catalog or the Parts and Accessories section of [www.harley-davidson.com](http://www.harley-davidson.com) (English only).

#### Installation Requirements

##### ⚠ WARNING

Rider and passenger safety depend upon the correct installation of this kit. Use the appropriate service manual procedures. If the procedure is not within your capabilities or you do not have the correct tools, have a Harley-Davidson dealer perform the installation. Improper installation of this kit could result in death or serious injury. (00333b)

##### NOTE

*This instruction sheet references service manual information. A service manual for your model motorcycle is available from a Harley-Davidson Dealer.*

#### Kit Contents

See Figure 1 and Table 1.

### INSTALL

##### ⚠ WARNING

To prevent accidental vehicle start-up, which could cause death or serious injury, remove main fuse before proceeding. (00251b)

1. Remove main fuse. See the service manual.
2. Disconnect front turn signals from main harness. See the service manual. Note wire routing and cable strap locations.
3. See Figure 1. Remove connector housing (F) from turn signal assembly harness. Note terminal (G) locations. See the service manual.

4. Remove right front turn signal assembly from original equipment (OE) location. See the service manual. Retain all mounting hardware. Note turn signal harness routing.
5. Remove nut (E), washer (D), and turn signal assembly (A) from OE turn signal mount.
6. Remove right pinch screw from the lower fork bracket.
7. Install pinch screw from right side of lower fork bracket to the upper pinch screw location. Tighten to 40.7–47.5 N·m (30–35 ft-lbs). See the service manual.
8. See Figure 1. Route the turn signal assembly terminals (G) and wiring through the turn signal mount (1).
9. Install turn signal assembly to turn signal mount. Secure with lockwasher (D) and nut (E). Tighten to 16.3–21.7 N·m (12–16 ft-lbs).
10. Install turn signal mount assembly to the lower fork bracket. Secure with previously removed upper pinch screw. Tighten pinch screw to 40.7–47.5 N·m (30–35 ft-lbs).
11. Repeat steps 4 through 11 for the left side front turn signal.
12. Route the turn signal wiring for each turn signal to the main harness as previously noted. Secure wiring with cable straps (2).
13. Install turn signal wire terminals (G) into the previously removed connector housing as noted. See the service manual.
14. Connect front turn signal connectors to main harness. See the service manual.
15. Install the main fuse. See the service manual.

##### ⚠ WARNING

Be sure that all lights and switches operate properly before operating motorcycle. Low visibility of rider can result in death or serious injury. (00316a)

16. Verify that turn signals operate properly.

# SERVICE PARTS

is08485

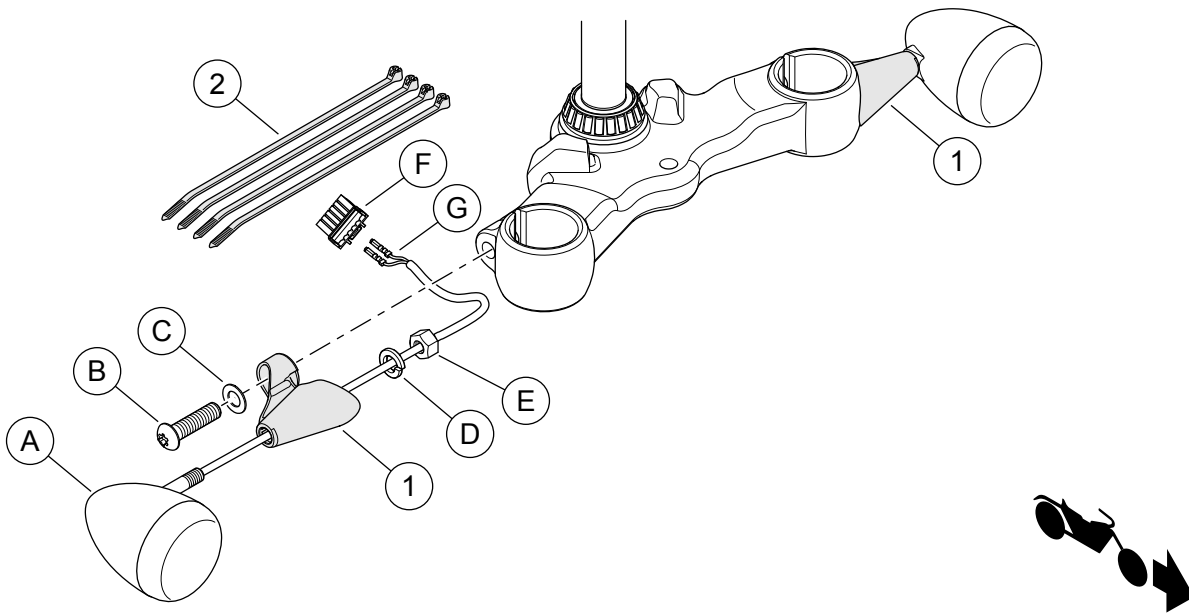

Figure 1. Service Parts: Front Turn Signal Relocation Kit - XL1200X

Table 1. Service Parts Table

Item	Description (Quantity)	Part Number
1	Turn signal mount (2)	Not Sold Separately
2	Cable strap (4)	10006
<b>Items mentioned in text, but not included in kit:</b>		
A	Front turn signal assembly	
B	Screw	
C	Flat washer	
D	Lockwasher	
E	Nut	
F	Connector housing	
G	Terminal	