



# INSTRUCTIONS

J05948

2014-05-01



## XL FORK SLIDER KITS

### GENERAL

#### Kit Number

45500258, 45500261

#### Models

For model fitment information, see the P&A Retail Catalog or the Parts and Accessories section of [www.harley-davidson.com](http://www.harley-davidson.com) (English only).

#### NOTE

*The fork sliders are direct replacements for the standard equipment fork sliders.*

### Installation Requirements

#### ⚠ WARNING

**Rider and passenger safety depend upon the correct installation of this kit. Use the appropriate service manual procedures. If the procedure is not within your capabilities or you do not have the correct tools, have a Harley-Davidson dealer perform the installation. Improper installation of this kit could result in death or serious injury. (00333b)**

#### NOTE

*This instruction sheet references service manual information. A service manual for your model motorcycle is required for this installation. Manuals are available from a Harley-Davidson dealer.*

- Harley-Davidson TYPE E FORK OIL (99884-80)
- Loctite® 243 Threadlocker and Sealant - Blue (99642-07)
- Loctite® Anti-Seize Lubricant (98960-97)
- Air impact wrench
- Torque wrench
- Fork spring compression tool
- Damper tube extension tool
- Fork Tube Holder HD-41177
- Front Fork Oil Level Gauge HD-59000-A
- Fork Seal and Bushing Tool HD-36583

### Kit Contents

See Figure 2 and Table 1.

### INSTALLATION

The chrome fork sliders included in this kit install in the same manner as the original equipment parts. See the service manual for proper installation procedures.

#### NOTE

*Check the bores of the new chrome sliders. Bores must be free of dirt and debris.*

#### ⚠ WARNING

**Block or jack vehicle under frame in a way that the vehicle will not fall over. Failure to properly block and/or raise the vehicle could result in death or serious injury. (00462c)**

1. Support the motorcycle with the front end off the floor and the forks are fully extended.
2. See the service manual. Remove the front fender, front brake calipers and front wheel.
3. See the service manual. Remove the front forks.
4. See the service manual. Drain the front forks.

#### NOTE

*Some models require that other parts be removed to access the front forks. See the service manual.*

#### ⚠ WARNING

**Wear safety glasses or goggles when servicing fork assembly. Do not remove slider tube caps without relieving spring preload or caps and springs can fly out, which could result in death or serious injury. (00297a)**

5. See the service manual. Disassemble the front fork tubes. Replace the original fork sliders with the sliders (see Figure 2, items 1 and 2) from the kit.
6. See the service manual. Assemble the front fork tubes. Replace worn seals, bushings or other items as needed. This kit includes new oil seals and tube cap O-rings.
7. See the service manual. Fill the forks with TYPE E FORK OIL (Part No. 99884-80).
8. See the service manual. Install the front forks.
9. See the service manual. Install the front fender, wheel, caliper and any parts that were removed to access the front forks.

#### NOTE

*Remove and clean the original equipment front fork reflectors on both sliders for installation on the new sliders.*

*Verify that the ambient temperature is **at least** 60° F (16° C) for proper adhesion of the reflectors to the sliders.*



**▲ WARNING**

Federal Motor Vehicle Safety Standard (FMVSS) 108 requires motorcycles to be equipped with rear and side reflectors. Be sure rear and side reflectors are properly mounted. Poor visibility of rider to other motorists can result in death or serious injury. (00336b)

- See Figure 2. Use a piece of dental floss (or similar material) in a back and forth motion to loosen the reflector. Rotate the reflector from side to side until it can be removed from the fork slider. Retain the reflector for installation to the **new** slider. Repeat the procedure on the opposite side fork slider.
- Remove any excess adhesive from both reflectors. Surface must be clean for installation.

**NOTE**

Make sure that the bottom edge of the reflector is 50 mm (2 in) above the center of the axle shaft.



**Figure 1. Reflector Placement**

- Peel the liner from one side of the foam double-sided tape. Position the tape to the back of the reflector. Press firmly into place. See Figure 1. Peel the remaining liner from the tape. Position the reflector on the fork slider. Press firmly into place. Repeat the procedure on the opposite side fork slider.

**NOTE**

Allow **AT LEAST 24 hours** after applying the reflectors before exposing the area to vigorous washing, strong water spray or extreme weather.

**▲ WARNING**

Whenever a wheel is installed and before moving the motorcycle, pump brakes to build brake system pressure. Insufficient pressure can adversely affect brake performance, which could result in death or serious injury. (00284a)

- Pump the brakes before test riding the motorcycle.
- Test ride the vehicle to check fork travel and rebound.

**SERVICE PARTS**

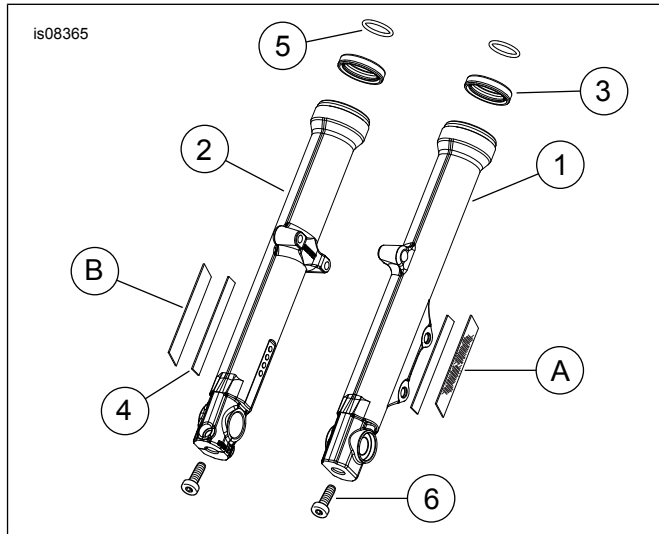

**Figure 2. Service Parts: XL Fork Slider Kits**

**Table 1. Service Parts: Fork Slider Kits**

Kit	Item	Description (Quantity)	Part No.
Kit 45500258 (Chrome)	1	Fork slider, left side (chrome)	45500259
	2	Fork slider, right side (chrome)	45500260
	3	Oil seal (2)	45378-87
	4	Tape, double sided foam (2)	53791-06
	5	O-Ring (2)	45984-87
	6	Bolt, socket (2)	45405-75A
Kit 45500261 (Black)	1	Fork slider, left side (black)	45500262
	2	Fork slider, right side (black)	45500263
	3	Oil seal (2)	45378-87
	4	Tape, double sided foam (2)	53791-06
	5	O-Ring (2)	45984-87
	6	Bolt, socket (2)	45405-75A
Items mentioned in text, but not included in kit:			
	A	Reflector, left	
	B	Reflector, right	