



# INSTRUCTIONS

J05951

2013-10-29



## FRONT FENDER PAINT GUARD KIT

### GENERAL

#### Kit Number

11100080

#### Models

For model fitment information, see the P&A Retail Catalog or the Parts and Accessories section of [www.harley-davidson.com](http://www.harley-davidson.com) (English only).

Harley-Davidson recommends that this kit be professionally installed.

#### Kit Contents

See Figure 1 and Table 1.

#### Installation Requirements

Separate purchase of two one-quart spray bottles, JOHNSON & JOHNSON® Baby Shampoo and 70% isopropyl alcohol.

Separate purchase of a 3M Squeegee (3M part number 71607 or equivalent) is required for proper installation of this instruction sheet.

### PREPARATION

#### NOTE

*Prepare solutions on the day of installation.*

1. Prepare two solutions in spray bottles:

- **Slip Solution:** Thoroughly mix 16 oz (473 mL) of distilled water and 2-3 drops of baby shampoo. The solution should sheet off the paint guards with minimum froth.

- **Tack Solution:** Using 70% isopropyl rubbing alcohol, mix a solution that is 10% alcohol and 90% distilled water.
- 2. See Figure 2. Wash all mounting areas thoroughly. Allow to dry completely.

#### Installation Tips and Tricks

- Do not apply to new paint (including touch-up paint). Allow paint to cure for a minimum of 30 days before applying the paint guards.
- Do not apply in windy conditions or in direct sunlight.
- Ambient temperature should be 60-90 °F (15-32 °C).
- Wash hands thoroughly and keep fingers wet with water/shampoo mixture during installation. To avoid fingerprints, do not touch adhesive with dry fingers.
- Keep paint guard film and squeegee wet during installation.
- See Figure 2. Identify each paint guard piece and its mounting location before proceeding.
- Start with the front of the piece.
- When smoothing the paint guards into place with the squeegee, work from the front edge toward the rear edge. Continually spray the paint guards with solution during the installation.
- The soap solution allows the paint guard to be slightly repositioned.
- The alcohol solution fixes the adhesive to the lids and can slightly stretch the paint guard film.
- If wrinkles are found after applying the alcohol solution, spray more alcohol solution under the wrinkle and squeegee again.

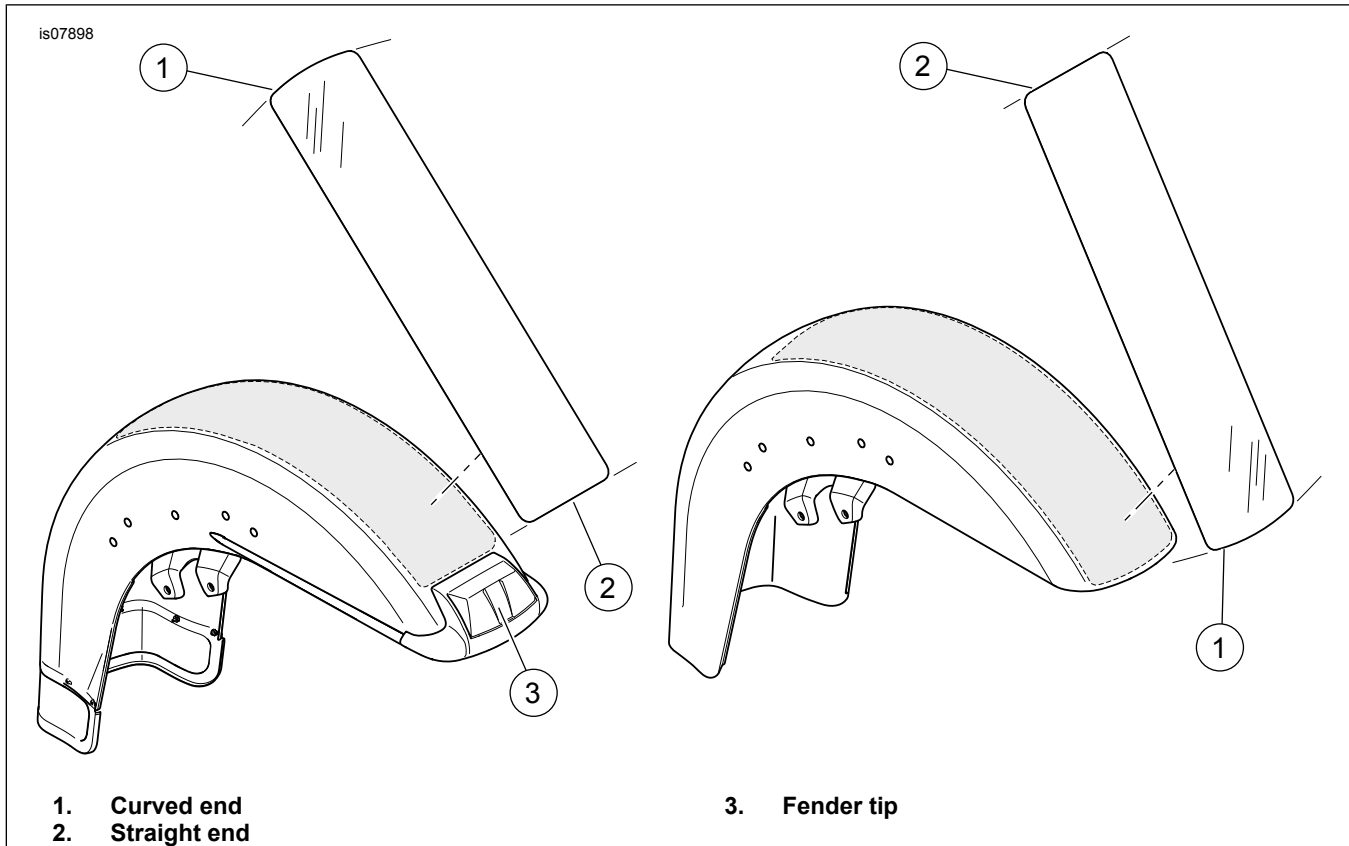

**Figure 1. Tape Orientation**

## INSTALLATION

### NOTE

- See Figure 1. On fenders with fender tip (3), straight end (2) of tape faces tip. On fenders without a fender tip, curved end (1) of tape faces front of fender.
- Start with the front of the piece.

1. Wet the mounting surface and fingers thoroughly with the soap solution.
2. See Figure 1. Align the paint guard with the front edge of the fender or fender tip.
3. Roll a small section of the paper backing away from the adhesive surface. Spray the adhesive surface with soap solution. Align with a straight edge of the mounting surface. When aligned properly, slow roll the remaining backing from the film.
4. When the backing is fully removed, spray the entire paint guard film with soap solution and smooth the film into place by hand.

### NOTE

*If repositioning is needed, spray more of the soap solution on the paint guard and hands and position as necessary.*

5. Once positioned properly, gently lift the leading edge of the film about half-way.

6. Spray the film and mounting surface with the water/alcohol mixture.
7. Starting from the front edge and working toward the back edge, use the squeegee to remove air bubbles. Use firm and overlapping strokes with the squeegee to work out all the air. Do not cut or tear the film.
8. Gently lift the other side of the film and repeat Steps 6 and 7.
9. Wipe paint guard dry with a Harley-Davidson® Microfiber Detailing Cloth (94663-02). Check for water pockets or air bubbles. If necessary, spray with more alcohol solution and squeegee again. If necessary, the paint guard film can still be lifted to reposition. Spray the paint guard film, the mounting surface and your fingers with the alcohol solution. Squeegee again until all water pockets and air bubbles are removed.

## FINAL INSTALLATION

1. Check the edges for adhesion. If any area is not adhered, wrap the squeegee with a Harley-Davidson® Microfiber Detailing Cloth (94663-02) and squeegee the edges again.
2. Allow the paint guards to cure for 24 hours. The paint guards can then be washed and waxed with the same recommended products used on the motorcycle. See the motorcycle owner's manual for recommended products.

# SERVICE PARTS

is07895

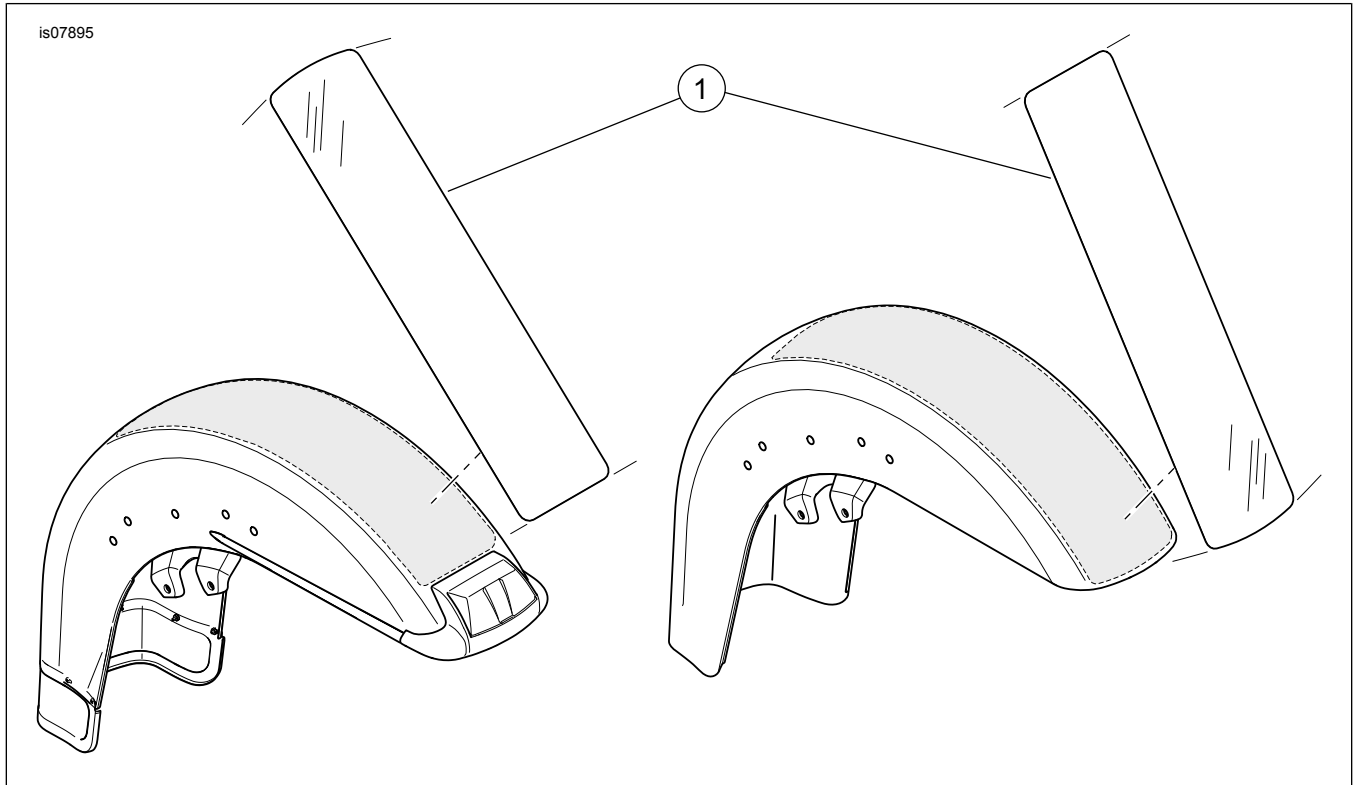

Figure 2. Service Parts: Paint Guard Kit

Table 1. Kit Contents

Item	Description (Quantity)	Part Number
1	Front fender	11100080