



# INSTRUCTIONS

J05956

2013-12-15



## FOOTPEG CONTROL KIT

### GENERAL

#### Kit Number

50500386

#### Models

For model fitment information, see the P&A Retail Catalog or the Parts and Accessories section of [www.harley-davidson.com](http://www.harley-davidson.com) (English only).

#### Additional Parts Required

Separate purchase and installation of additional parts or accessories may be required for proper installation of this kit on your model motorcycle. See the P&A Retail Catalog or the Parts and Accessories section of [www.harley-davidson.com](http://www.harley-davidson.com) (English only) for a list of required parts or accessories for your model.

### ⚠ WARNING

Rider and passenger safety depend upon the correct installation of this kit. Use the appropriate service manual procedures. If the procedure is not within your capabilities or you do not have the correct tools, have a Harley-Davidson dealer perform the installation. Improper installation of this kit could result in death or serious injury. (00333b)

### NOTE

*This instruction sheet references service manual information. A service manual for your model motorcycle is required for this installation and is available from a Harley-Davidson dealer.*

### Kit Contents

See Figure 1 and Table 1.

### INSTALLATION

The parts in this kit are direct replacements for the original equipment (OE) parts. See the service manual to remove, install and adjust the shift lever, brake pedal and footpeg support brackets.

### SERVICE PARTS

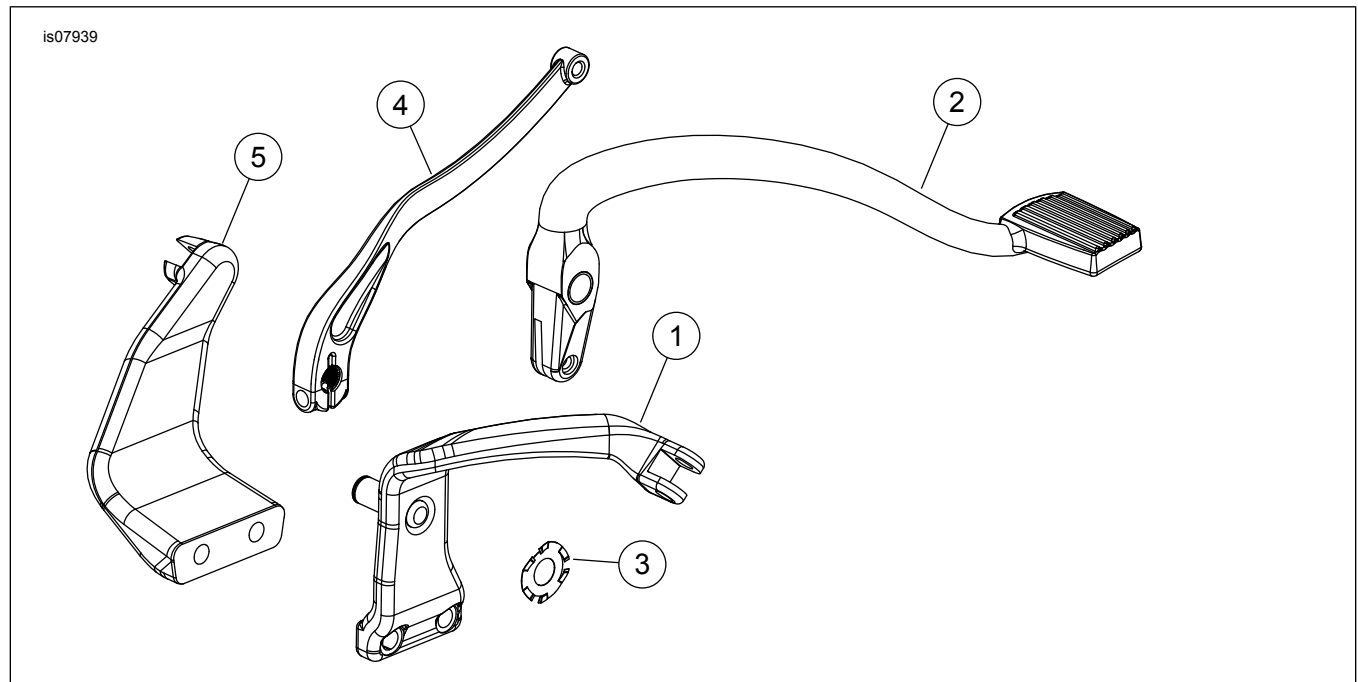

Figure 1. Service Parts: Footpeg Control Kit

**Table 1. Service Parts Table**

<b>Item</b>	<b>Description (Quantity)</b>	<b>Part Number</b>
1	Footpeg support bracket, right	50500276
2	Brake pedal assembly	50600127
3	Spring washer	7003
4	Foot shift lever	33900147
5	Footpeg support bracket, left	50500279