



# INSTRUCTIONS

J05541

2014-09-11



## XL FUEL LEVEL SENSOR KIT

### GENERAL

#### Kit Number

61200008A

#### Models

For model fitment information, see the P&A Retail Catalog or the Parts and Accessories section of [www.harley-davidson.com](http://www.harley-davidson.com) (English only).

#### Additional Parts Required

##### ⚠ WARNING

Rider and passenger safety depend upon the correct installation of this kit. Use the appropriate service manual procedures. If the procedure is not within your capabilities or you do not have the correct tools, have a Harley-Davidson dealer perform the installation. Improper installation of this kit could result in death or serious injury. (00333b)

##### NOTE

*This instruction sheet references service manual information. A service manual for your model motorcycle is required for this installation and is available from a Harley-Davidson dealer.*

#### Kit Contents

See Figure 3 and Table 1.

### INSTALLATION

#### Install Fuel Level Sensor

##### ⚠ WARNING

When servicing the fuel system, do not smoke or allow open flame or sparks in the vicinity. Gasoline is extremely flammable and highly explosive, which could result in death or serious injury. (00330a)

##### ⚠ WARNING

To prevent spray of fuel, purge system of high-pressure fuel before supply line is disconnected. Gasoline is extremely flammable and highly explosive, which could result in death or serious injury. (00275a)

##### ⚠ WARNING

Gasoline can drain from components when disconnected from fuel pump/filters/fuel level sender assembly. Gasoline is extremely flammable and highly explosive, which could result in death or serious injury. Wipe up spilled fuel immediately and dispose of rags in a suitable manner. (00273a)

1. See the service manual and purge the fuel supply line high-pressure gasoline, then disconnect the fuel supply line from the fuel pump module.
2. See the service manual. Remove the seat and the main fuse.
3. See the service manual and remove the fuel tank.
4. See the service manual and remove the fuel pump.
5. See the service manual and remove the low fuel level sender.
6. See Figure 1. Install new sensor as follows:
  - a. Install fuel sensor into fuel pump module oriented as shown and locating the base into the mounting hole (4) of the fuel pump.
  - b. Hold the fuel sensor against the mounting tab. Look at the gap between the fuel hose and the sensor. The gap must be at least 1.5 mm (0.06 in). If gap is too small or there is contact between fuel hose and fuel sensor, rotate fuel filter approximately 3.3 mm (0.13 in) to move fuel hose away from fuel sensor. If gap is still too small, remove fuel sensor and bend mounting tab slightly away from fuel hose until gap is sufficient.
  - c. Look at the gap between the fuel sensor and fuel pump wiring. The gap must be at least 1.5 mm (0.06 in). If necessary, move wiring with a blunt tool, such as a screwdriver.
  - d. Secure the fuel level sensor to the fuel pump with screw (3). Tighten the screw enough to seat the fuel sensor against the mounting tab.
  - e. Route fuel level sensor wiring under fuel hose and connect fuel level sensor to the low fuel switch connector on fuel pump module. If necessary use the jumper harness ( Figure 3, item 3).
  - f. See Figure 2. Secure the fuel pump wires and connectors.



is06164

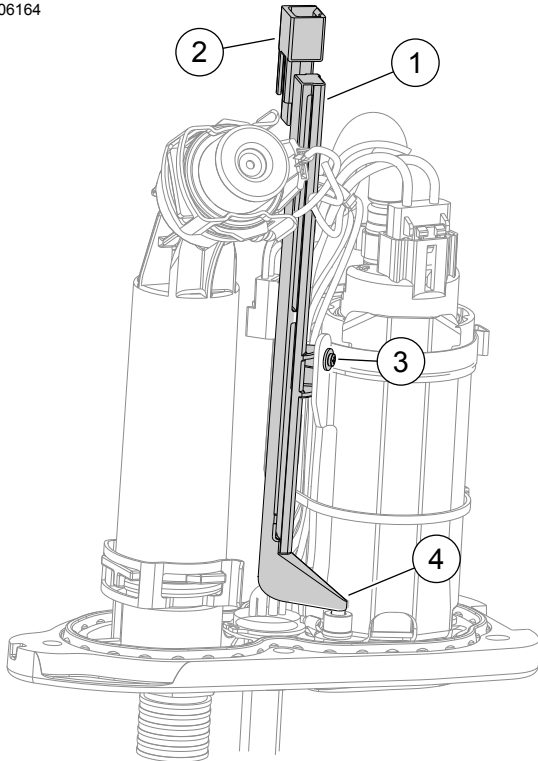

1. Fuel level sensor
2. Fuel level sensor connector
3. Screw
4. Fuel level sensor mounting location

Figure 1. Install Fuel Level Sensor

is06222



Figure 2. Secure Fuel Pump Wires and Connectors

7. See the service manual and install the fuel pump and the new gasket included in the kit.

8. Install wire jumper (8) as follows:

- a. Find fuel sender resistor connector [200B] located between the oil tank and frame near the seat pan.
- b. Disconnect the fuel sensor resistor assembly [200A] from connector [200B].
- c. Install wire jumper (8) to cavity 1 and 2 of pin housing (7) and use seal pin (6) to plug remaining cavity 3.
- d. Install pin housing with wire jumper (8) into connector [200B].

9. Secure the fuel gauge harness and orange wire to the main harness with cable straps (4). Coil and secure excess harness and wire length.

10. See the service manual and install the fuel tank.

11. See the service manual and install the main fuse.

### ▲ WARNING

After installing seat, pull upward on seat to be sure it is locked in position. While riding, a loose seat can shift causing loss of control, which could result in death or serious injury. (00070b)

12. See the service manual and install the seat.

## SERVICE PARTS

is06187b

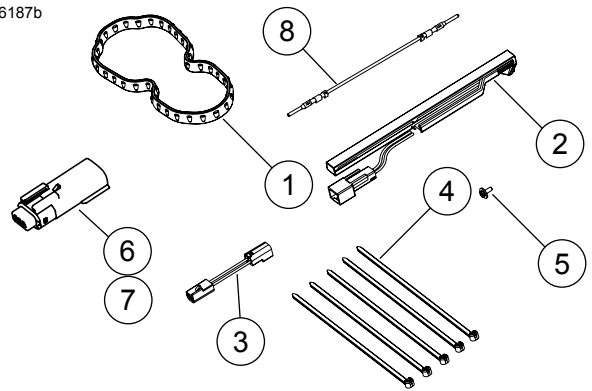

Figure 3. Service Parts for Sportster Fuel Gauge

Table 1. Service Parts Table

Item	Description (Quantity)	Part Number
1	Seal, fuel pump cover plate	75301-07
2	Sensor, fuel gauge	61200040
3	Harness, jumper	70449-09
4	Cable strap (5)	10181
5	Screw, sems	2492
6	Seal pin (3)	72473-07
7	Pin housing	72511-07BK
8	Wire, jumper, fuel gauge	Not Sold Separately