



INSTRUCTIONS

J05780

2013-05-31



TRIKE CHROME FORK SLIDERS

GENERAL

Kit Number

45500200

Models

For model fitment information, see the P&A Retail Catalog or the Parts and Accessories section of www.harley-davidson.com (English only).

Installation Requirements

Harley-Davidson TYPE E FORK OIL (99884-80) is required.

Loctite[®] 243 Threadlocker and Sealant - Blue (99642-07)

Loctite[®] Anti-Seize Lubricant (98960-97)

⚠ WARNING

Rider and passenger safety depend upon the correct installation of this kit. Use the appropriate service manual procedures. If the procedure is not within your capabilities or you do not have the correct tools, have a Harley-Davidson dealer perform the installation. Improper installation of this kit could result in death or serious injury. (00333b)

NOTE

This instruction sheet references service manual information. A service manual for your model motorcycle is required for this installation and is available from a Harley-Davidson Dealer.

Tools Required

- Air impact wrench
- Torque wrench
- Fork spring compression tool
- Damper tube extension tool
- Fork Tube Holder HD-41177
- Front Fork Oil Level Gauge HD-59000-A
- Fork Seal and Bushing Tool HD-36583

Kit Contents

See Figure 2 and Table 1.

INSTALLATION

The chrome fork sliders included in this kit install in the same manner as the original equipment parts. See the service manual for proper installation procedures.

NOTE

Before installing this kit, check the bores of the new chrome sliders. Bores must be free of dirt and debris or damage to the sliders may occur.

⚠ WARNING

Block or jack vehicle under frame in a way that the vehicle will not fall over. Failure to properly block and/or raise the vehicle could result in death or serious injury. (00462c)

1. Support the motorcycle so the front end is off the floor and the forks are fully extended.
2. See the service manual. Remove the front fender, front brake caliper(s), and front wheel.
3. See the service manual. Remove the front forks.
4. See the service manual. Drain the front forks.

NOTE

On some models, other parts need to be removed to access the front forks. See the service manual.

⚠ WARNING

Wear safety glasses or goggles when servicing fork assembly. Do not remove slider tube caps without relieving spring preload or caps and springs can fly out, which could result in death or serious injury. (00297a)

5. See the service manual. Disassemble the front fork tubes. Replace the original fork sliders with the chrome sliders (see Figure 2, items 1 and 2) from the kit.
6. See the service manual. Assemble the front fork tubes. Replace worn seals, bushings or other items as needed. This kit includes new oil seals and tube cap O-rings.
7. See the service manual. Fill the forks with TYPE E FORK OIL (Part No. 99884-80).
8. See the service manual. Install the front forks.
9. See the service manual. Install the front fender, wheel, caliper and any parts that were removed to access the front forks.

NOTE

Remove and clean the original equipment front fork reflectors on both sliders for installation on the new sliders.

*Make sure ambient temperature is **at least 60° F (16° C)** for proper adhesion of the reflectors to the sliders.*



▲ WARNING

Federal Motor Vehicle Safety Standard (FMVSS) 108 requires motorcycles to be equipped with rear and side reflectors. Be sure rear and side reflectors are properly mounted. Poor visibility of rider to other motorists can result in death or serious injury. (00336b)

- Using a piece of dental floss (or similar material) in a back and forth motion, loosen the reflector (Figure 2, A). Rotate the reflector from side to side until it can be removed from the fork slider. Retain the reflector for installation to the new slider. Repeat the procedure on the opposite side fork slider.
- Remove any excess adhesive from both reflectors. Surface must be clean for reinstallation.

NOTE

Make sure that the bottom edge of the reflector is 50 mm (2 in) above the center of the axle shaft.



Figure 1. Reflector Placement

- Peel the liner from one side of the foam double-sided tape. Position the tape to the back of the reflector. Press firmly into place. Peel the remaining liner from the tape. Place the reflector in position on the fork slider as shown in Figure 1. Press firmly into place. Repeat the procedure on the opposite side fork slider.

NOTE

Allow AT LEAST 24 hours after applying the reflectors before exposing the area to vigorous washing, strong water spray or extreme weather.

▲ WARNING

Whenever a wheel is installed and before moving the motorcycle, pump brakes to build brake system pressure. Insufficient pressure can adversely affect brake performance, which could result in death or serious injury. (00284a)

- Pump the brakes before test riding the motorcycle.
- Test ride the vehicle to check fork travel and rebound.

SERVICE PARTS

is07640

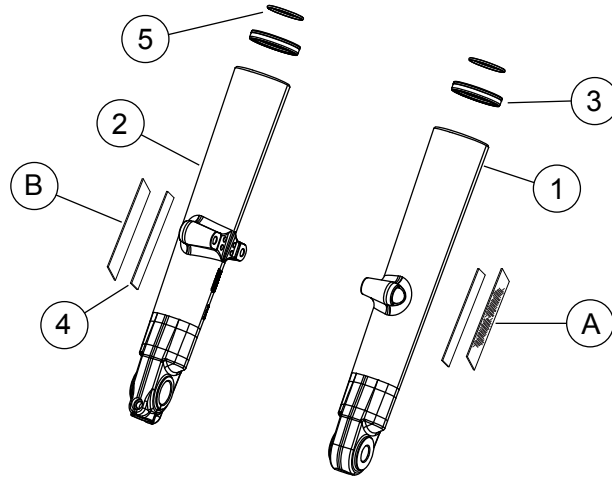

Figure 2. Service Parts: Trike Chrome Fork Sliders

Table 1. Service Parts: Chrome Fork Sliders

Item	Description (Quantity)	Part Number
1	Fork slider, left side, (chrome)	45500202
2	Fork slider, right side (chrome)	45500201
3	Oil seal (2)	46514-01A
4	Tape, double sided foam (2)	53791-06
5	O-ring (2)	46508-01
Items mentioned in text, but not included in kit:		
A	Reflector, left	59482-00
B	Reflector, right	59481-00