



INSTRUCTIONS

J05974

2014-11-18



VINTAGE WHITE SHIFTER PEG

GENERAL

Kit Number

33600071

Models

For model fitment information, see the P&A Retail Catalog or the Parts and Accessories section of www.harley-davidson.com (English only).

NOTE

A service manual for your model motorcycle is available from a Harley-Davidson dealer.

Kit Contents

See Figure 1 and Table 1.

INSTALLATION

1. Remove previously installed shifter peg from motorcycle. Discard peg and screw.
2. See Figure 1. Insert peg stud (1) into shifter peg rubber (2). Install to shift pedal.
3. Tighten screw to 15–20 N·m (11–15 ft-lbs).

In Use

If your white footpegs become discolored, the use of a clean white cloth and common dish soap or Harley-Davidson Wheel and Tire Cleaner (Part No. 93600024) to clean the footpegs will aid in removing any discoloration or stains. Rinse with clean water and dry thoroughly.

SERVICE PARTS

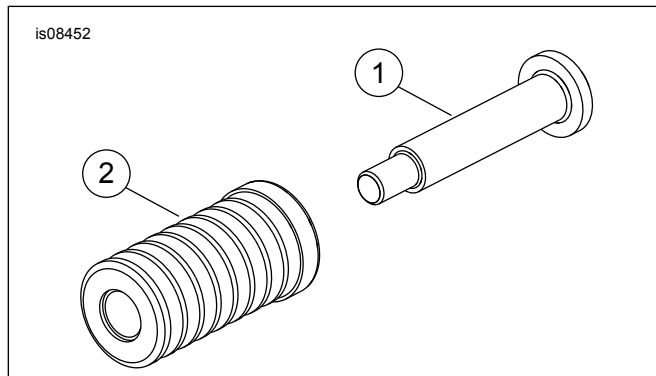

Figure 1. Service Parts: Vintage White Shifter Peg

Table 1. Service Parts

Item	Description (Quantity)	Part Number
1	Stud Peg	Not Sold Separately
2	Shifter Peg Rubber	Not Sold Separately

