



# INSTRUCTIONS

J06079

2015-08-04



## FRONT FENDER SKIRT KIT

### GENERAL

#### Kit Numbers

61400311, 61400312

#### Models

For model fitment information, see the P&A retail catalog or the Parts and Accessories section of [www.harley-davidson.com](http://www.harley-davidson.com) (English only).

#### Kit Contents

See Figure 2 and Table 1.

There are no service parts available for this kit.

### INSTALLATION

#### Replacement Skirt Installation

1. See Figure 2. Remove screws, washers and nuts securing existing fender skirt to fender. Discard fender skirt and hardware.
2. Clean the fender in the skirt mounting area with a mixture of 50 percent isopropyl alcohol and 50 percent distilled water. Allow to dry completely.

#### NOTE

Install the **new** washers on the **inside** of the fender.

3. Get the **new** fender skirt (1), fender skirt mounting screws (2), washers (3) and nuts (4) from the kit. Align the fender skirt as shown. Install skirt to fender, but do not fully tighten. Follow the tightening sequence in Figure 2 inset. Press the fender skirt firmly against the fender at each hole in turn while tightening the mounting hardware to 1.1–1.7 N·m (10–15 in-lbs).

#### Clean Fender Installation

#### ▲ WARNING

**Do not contact tire with drill bit when drilling fender holes. Drill bit contact with tire can lead to premature tire failure, which could result in death or serious injury. (00403f)**

#### NOTE

To install this skirt kit on a Clean Front Fender, perform the following:

1. Clean the fender in the skirt mounting area with a mixture of 50 percent isopropyl alcohol and 50 percent distilled water. Allow to dry completely.
2. See Figure 1. Cover **that** portion of fender with masking tape to protect painted surface during positioning of skirt and drilling of mounting holes (1).

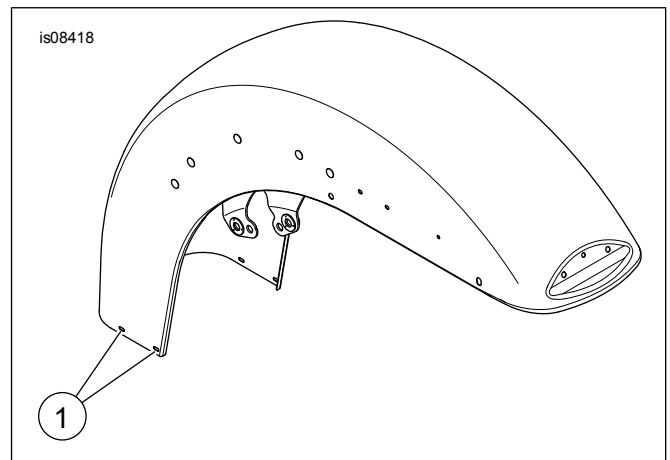
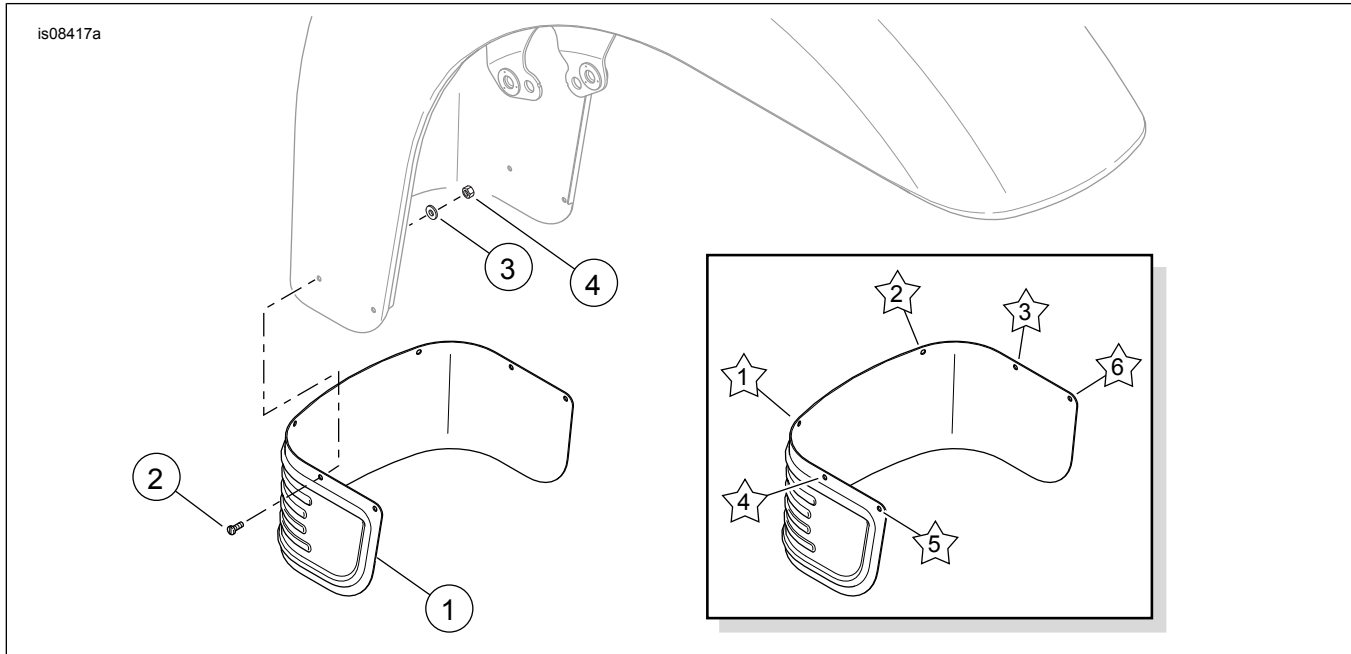

Figure 1. Clean Front Fender Hole Locations

3. Place fender skirt in desired location and mark mounting hole locations with felt tip pen. Align the lower edge of the fender skirt parallel to, but slightly below the lower edge of the fender.
4. Remove fender skirt. Carefully center punch holes at marked locations.
5. Drill mounting holes using a 3 mm (1/8 in) diameter drill bit.
6. Remove masking tape. Attach fender skirt as described under **Replacement Skirt Installation**, Step 3.



# SERVICE PARTS



**Figure 2. Service Parts: Front Fender Skirt, Chrome or Black**

**Table 1. Service Parts Table**

Item	Description (Quantity)	Part Number
1	Skirt, front fender	Not sold separately
2	Machine screw, pan head, #4-40 x 8 mm (0.31 in) long, stainless steel (6)	Not sold separately
3	Flat washer, #4, stainless steel (6)	Not sold separately
4	Hex nut, Nyloc, #4-40, stainless steel (6)	Not sold separately