



INSTRUCTIONS

J05557

2015-03-20



FL TOURING CVO-STYLE REAR FENDER KITS

GENERAL

Kit Numbers

59500105BEO, 59500122BEO

Models

For model fitment information, see the P&A retail catalog or the Parts and Accessories section of www.harley-davidson.com (English only).

Table 1. Models

Kit	Fender
59500105BEO	Prime paint, United States only
59500122BEO	Prime paint, all other applications

Installation Requirements

Models equipped with saddlebag guard RAILS requires separate purchase of a Saddlebag Support Kit or a Saddlebag Guard Kit without rails.

Separate purchase of extra parts or accessories may be required for proper installation of this Rear Fender Kit on certain model motorcycles.

See the P&A retail catalog or the Parts and Accessories section of www.harley-davidson.com (English only) for a list of required parts or accessories for a specific model.

A wallpaper seam roller is required for proper installation of the lighting harness in this kit.

The help of an assistant aids in the removal and placement of the fender.

⚠ WARNING

Rider and passenger safety depend upon the correct installation of this kit. Use the appropriate service manual procedures. If the procedure is not within your capabilities or you do not have the correct tools, have a Harley-Davidson dealer perform the installation. Improper installation of this kit could result in death or serious injury. (00333b)

NOTE

This instruction sheet refers to service manual information. A service manual for this year/model motorcycle is required for this installation. One is available from a Harley-Davidson dealer.

Kit Contents

See Figure 6 and Table 2.

PREPARATION

NOTE

For vehicles equipped with security siren:

- Verify that the hands-free Fob is present.
- Turn ignition switch ON.

1. Remove the saddlebags. See the service manual.
2. Remove the left and right side covers per the service manual.

⚠ WARNING

To prevent accidental vehicle start-up, which could cause death or serious injury, remove main fuse before proceeding. (00251b)

3. See the service manual. Remove main fuse.
4. Remove seat. Retain the seat and all mounting hardware.
5. See Figure 1. **Models with saddlebag GUARD RAILS (1):** Remove the saddlebag guard rail assemblies on each side of the vehicle per the service manual. Save the mounting hardware for later installation. The saddlebag guard rail assemblies can be recycled or properly disposed of. **Models with original equipment (OE) saddlebag SUPPORTS (2):** Remove the TORX® head screw (4) at the top rear of the support on each side of the vehicle, and set aside for later installation. **Models with Genuine Motor Accessory Chrome Saddlebag SUPPORT Kit (Part No. 90881-09A) or GUARD Kits (Part Nos. 49179-09, 49282-09B or 49283-09, Item 3):** Remove the TORX head screw (4) at the top rear of the support on each side of the vehicle, and set aside for later installation.



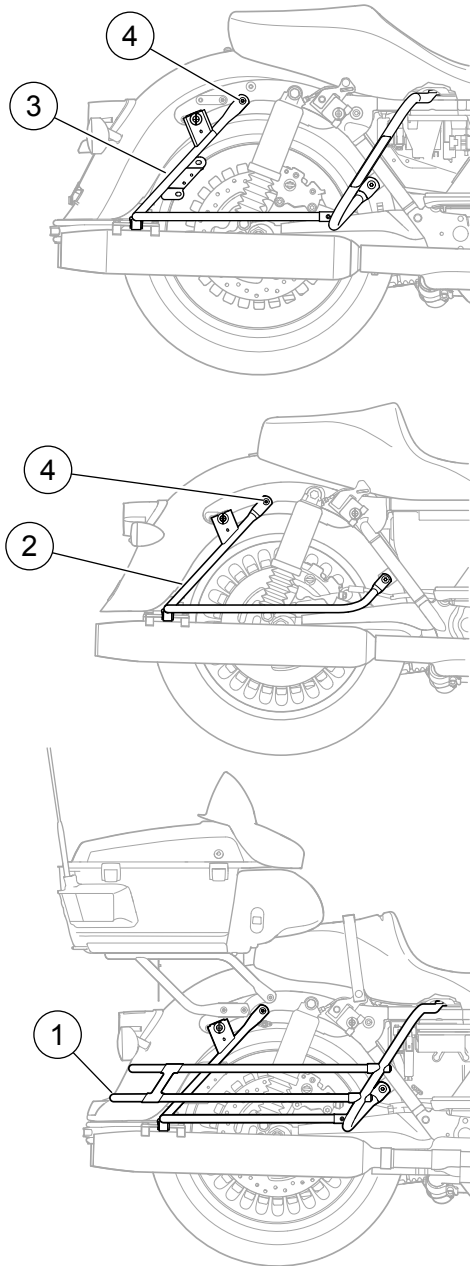

1. Twin rail saddlebag guard (FLHTC/FLHTCU style)
2. Saddlebag support (FLHX/FLTR style)
3. Saddlebag guard (FLHR/FLHT/FLHTK style)
4. Remove this screw (2)

Figure 1. Original Equipment Saddlebag Supports and Guards

6. **ALL models:** Remove the license plate (if installed), and set aside for later installation. The license plate bracket and reflector can remain on the fender.
7. See the service manual to remove and save the following items if equipped:
 - Tour-Pak[®] luggage rack or Tour-Pak support,
 - Rider backrest,

- Passenger backrest,
 - Grab rail, reinforcement plate and fasteners.
8. Release the air pressure in the rear suspension per the service manual. Disconnect the right side shock absorber hose at one end.

FENDER REMOVAL

NOTE

The help of an assistant aids in the removal of the fender.

1. Follow service manual instructions to remove the rear fender from the vehicle, with the following exception:
 - a. The tail lamp assembly, turn signal bar, rear fender tip lamp, rear lighting harness (and **if equipped**, the rear fascia and rear fascia lamp) **do not** need to be removed from the fender.

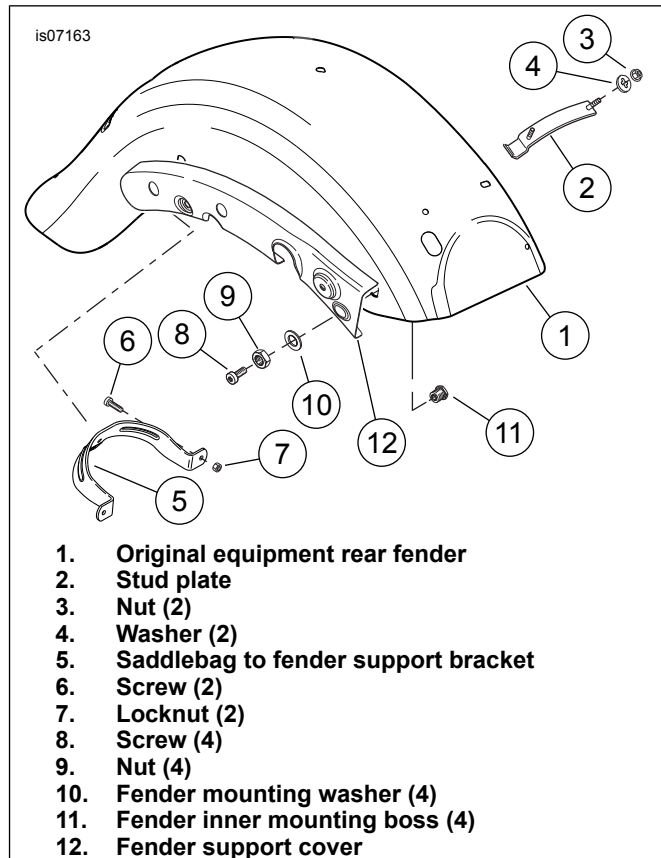

1. Original equipment rear fender
2. Stud plate
3. Nut (2)
4. Washer (2)
5. Saddlebag to fender support bracket
6. Screw (2)
7. Locknut (2)
8. Screw (4)
9. Nut (4)
10. Fender mounting washer (4)
11. Fender inner mounting boss (4)
12. Fender support cover

Figure 2. Remove Rear Fender Items

2. See Figure 2. Remove the following items from the OE fender (1), and set aside for later installation to the **new** fender: The fender, attaching hardware and all remaining assembled items can be recycled or properly disposed of.
 - a. The stud plate (2), two nuts (3) and two washers (4) at the front of the fender, and
 - b. the saddlebag to fender support bracket (5), two screws (6) and two locknuts (7) at the rear of the fender.
 - c. **For Ultra models:** Save the chrome fender support covers for later installation.

FENDER ASSEMBLY

NOTE

- The rear fender, fascia and license plate light cover must be finish painted before assembly.
- **ALL models except FLHTCU/FLHTCUSE:** Prime painted fender support covers must be finish painted before assembly.

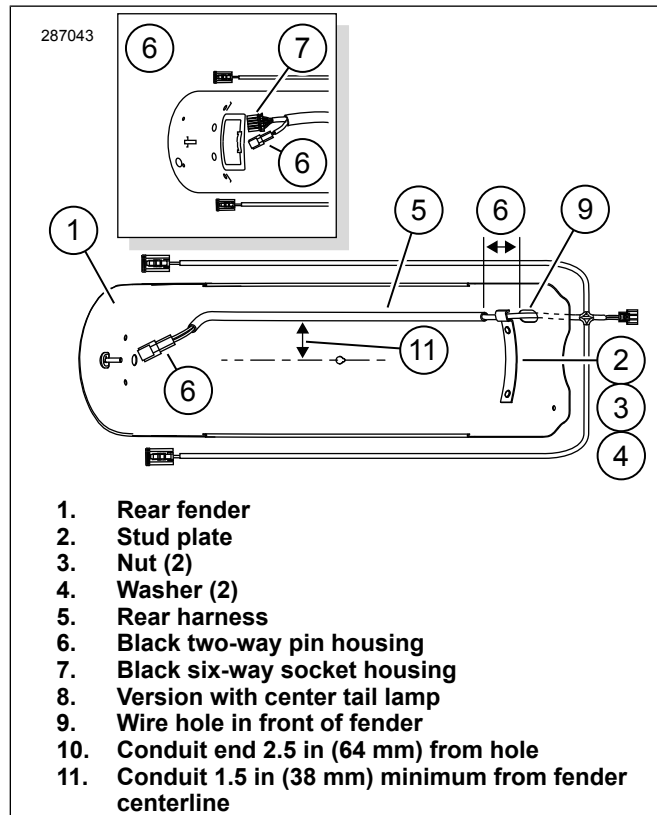

Figure 3. Install Rear Fender Harness

Harness Installation

NOTE

- Ambient temperature of **at least** 16 °C (60 °F) for proper adhesion of the harness conduit to the fender.
- Allow **AT LEAST** 24 hours after applying the harness before exposing the area to strong water spray or extreme weather.

- The adhesive bond will increase to maximum strength after about 72 hours at normal room temperature.

1. See Figure 3. Clean with a mixture of 50 percent isopropyl alcohol and 50 percent distilled water. Allow to dry completely. Do not use solvents or harsh chemicals that could damage painted surfaces.
2. Get the stud plate (2) removed from the OE fender, and with the channel nearest the wire hole, loosely assemble the plate to the inside front of the fender with the OE nuts (3) and washers (4). Do not fully tighten.

NOTE

The two branches of the rear lighting harness without adhesive conduit remain **outside** the fender.

3. Install the rear harness (5) to the underside of the fender:
 - a. Feed the main body of the harness (with adhesive conduit) through the wire hole (9) in the front of the fender from the outside.
 - b. Lay the harness along the length of the fender. Position the forward end of the adhesive conduit about 64 mm (2 1/2 in) from the wire entry hole. Lay the conduit a **minimum** of 38 mm (1 1/2 in) from the centerline of the fender. Mark the position of the conduit on the fender.
 - c. Beginning at the rear, pull the tab on the harness conduit to expose the adhesive while pressing the conduit into place along the length of the fender. Use a wallpaper seam roller to press the conduit securely in place. At the front, capture the wire harness under the stud plate channel.
 - d. Tighten the stud plate nuts to 6.8–10.9 N·m (60–96 in-lbs).

NOTE

- Assembly and installation of the fender may proceed, but take care to pulling or repositioning the adhesive conduit.
- Allow the adhesive 72 hours to fully cure.

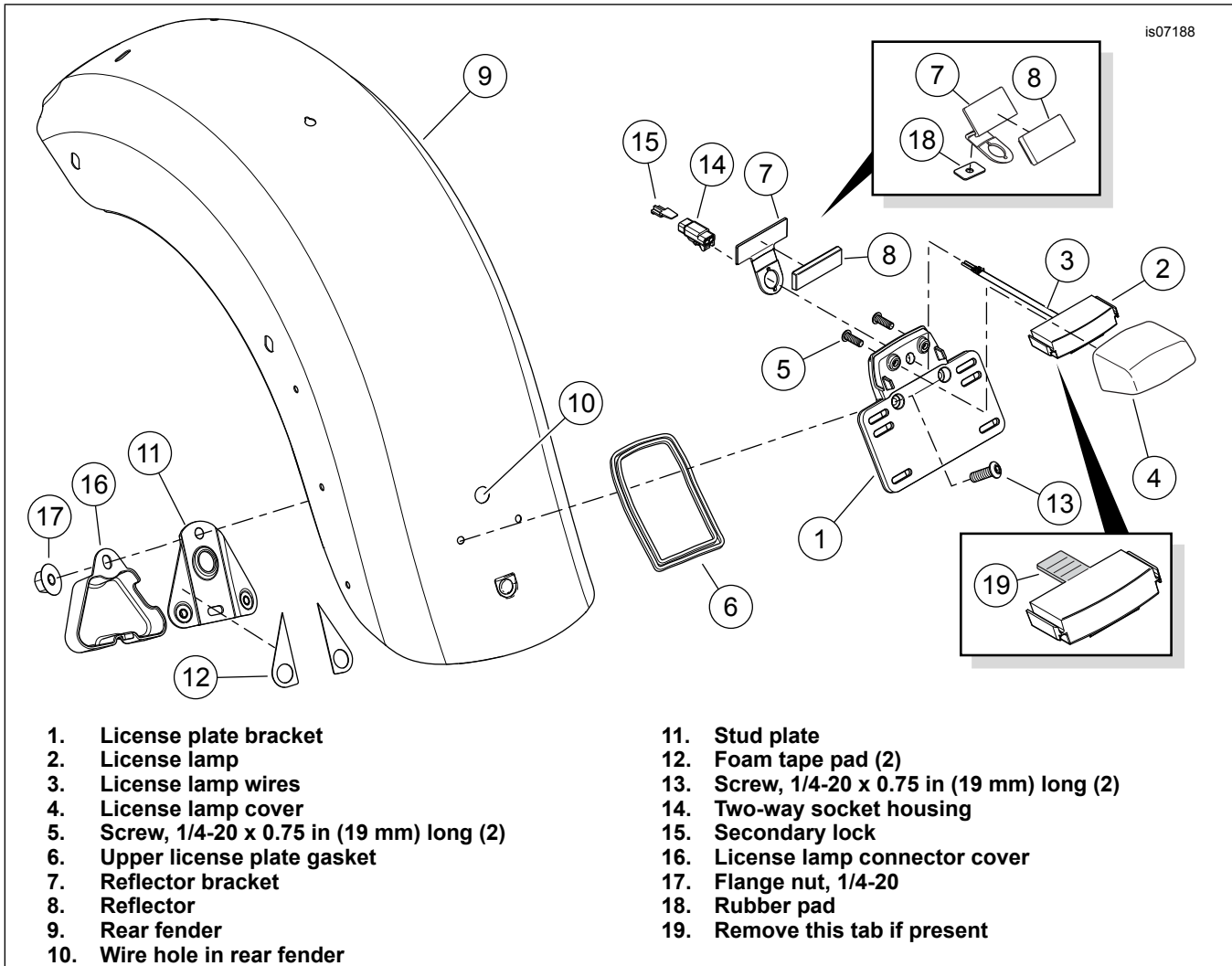

Figure 4. License-Plate Lamp and Bracket Installation

License Lamp Installation

NOTE

Some license lamps have a tab (see Figure 4 inset, Item 19) that will prevent installation. Remove the tab before proceeding.

1. See Figure 4. Assemble the license lamp (2) and cover (4) to the license plate bracket (1). Tighten the screws (5) to 6.4–7.8 N·m (57–69 in-lbs).
2. Get the stud plate (11) and two foam tape pads (12) from the kit. Remove the liner from the adhesive backing on one side of one pad. Carefully position the pad to a flange of the stud plate, on the side opposite the nuts. Press firmly into place. Repeat with the second pad on the remaining flange. Remove the liner from the exposed side of the pads.
3. Get the correct reflector (8) and bracket (7) from the kit. Remove the liner from the adhesive backing of the reflector. Install to the bracket as shown.

NOTE

HDI models using reflector bracket 60921-09 (see Figure 4): Remove the liner from the adhesive backing of the 30 x 19 x 1.6 mm (x in) rubber pad (18). Position the pad to the back of the reflector bracket (7), just above the hole as shown. Press firmly into place.

4. While holding the gasket (6) in place, feed the lamp wires (3) through the license bracket (1), reflector bracket (7), and the hole (10) in the fender (9).
5. Hold the stud plate (11) in place on the underside of the fender. Secure the license plate bracket (1) to the stud plate with screws (13). Tighten the screws securely.
6. Insert the license lamp wires into the two-way socket housing (14) per the service manual. Secure with the secondary lock (15). Plug the two-way pin housing on the rear harness into the license lamp socket [45B].
7. Install the license lamp connector cover (16). Secure with a flange nut (17). Tighten the nut to 3.4–5.1 N·m (30–45 in-lbs).
8. Secure the wire harness with the clip on the inside of the fender.

Center Stop/Tail Lamp Installation (For Models So Equipped)

Install the **new** center stop/tail lamp per service manual instructions.

Rear Fascia Installation

1. See Figure 2. Install a **new** fender mounting boss (11), from the inside, through one of the four holes in the sides of the fender. Place a washer (10) onto the threads of the boss, and fasten with a nut (9). Tighten the nut to 20.3–27.1 N·m (15–20 ft-lbs). Repeat for the remaining three holes.

2. See Figure 5. Remove the liner from the adhesive backing of the 44.5 x 19 x 1.6 mm (x in) rubber pad (2). Position the pad to the center of the fascia (1), just below the slot as shown. Press firmly into place.
3. Position the fascia under the rear edge of the fender, aligning the three holes on each side of the fascia with the mating holes in the fender. Insert the three studs of a stud plate (3), from beneath the fender, through the holes in the fender and fascia on one side.

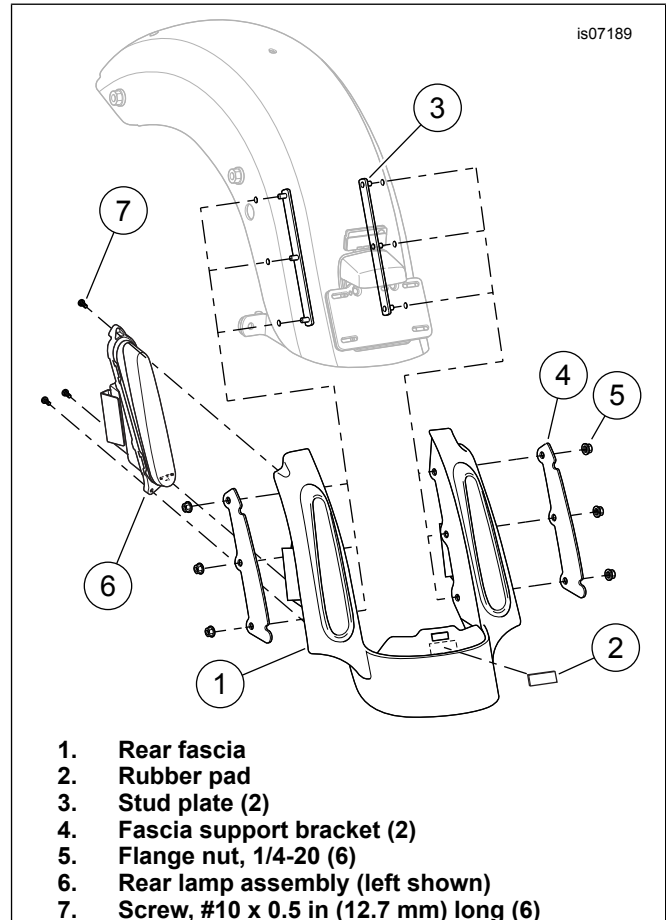

Figure 5. Rear Fascia Installation

4. Install a fascia support bracket (stiffener plate, 4) over the studs, and loosely install three flange nuts (5) onto the stud threads.
5. Loosely fasten the other side of the fascia with the remaining stud plate, support bracket and flange nuts. Alternately tighten each flange nut to 3.4–5.1 N·m (30–45 in-lbs).

NOTE

The fascia-mounted LED lamps are side-specific. The outboard edge of the lens curves up and inward matching the opening in the fascia.

Remove the blue film from the lens face **before** the lamp is installed in the fascia.

6. Install a rear fascia lamp (6) into the correct-side opening in the fascia from behind. Fasten with three black #10 TORX® screws (7). Alternately tighten each screw to 1.6–2.1 N·m (14–18 in-lbs). Repeat for the remaining fascia lamp.

Antenna Relocation on FLHX and FLHTRX Models

1. See Figure 6. Disconnect the antenna cable from the antenna base assembly.
2. Unscrew the antenna mast from the antenna base.
3. Remove the lower locknut. Remove the antenna base from the mounting bracket.
4. Remove the two screws and lockwashers retaining the antenna mounting bracket.
5. Remove and discard any cable straps securing the antenna cable to the fender support and saddlebag rear support brackets.
6. Obtain the new antenna bracket (31), new Spacers (35 and 36), new screws (37), new flat washers (38), and new antenna base assembly (31).
7. Position the antenna bracket near the fender supports as shown in Figure 5 and fasten the bracket to the fender supports:
 - a. Assemble the thin washer (38) to the screw threads.
 - b. Install screws through antenna bracket from rear.
 - c. Slide the spacers onto the threads that are extending through the bracket. Note the spacer lengths. Reference Figure 5.
 - d. Align and fasten this bracket and fastener assembly to the fender support and tighten to 20.3–27.1 N·m (15–20 ft-lbs).
8. Install internal tooth lockwasher (33) from the kit onto the larger threads of the antenna base (32), under the hex nut (34). Insert the antenna base through the hole in the antenna mounting bracket.
9. Install the second hex nut (34) onto the threads of the antenna base. Place a wrench on the upper nut and tighten the lower nut to 8 N·m (6 ft-lbs).
10. Plug the antenna cable connector into the antenna base. Tighten the knurled nut to secure the connector to the antenna base. Allow slack in the cable at the antenna base to avoid kinking or binding at the connection.
11. Fasten the antenna cable to the fender support bar with a cable strap. Use a second cable strap to tie the antenna cable (FLHX models, the excess rear fascia lamp wires) to the frame rail, near the suspension air lines, underneath the painted cover. DO NOT tie the cable to the air lines.

12. Thread the antenna mast assembly securely onto the antenna base (31).

FENDER INSTALLATION

NOTE

- *The help of an assistant could in the placement of the fender onto the motorcycle.*
 - *Protect the lower edges of the fascia beneath the tail lamps with tape to prevent the mufflers damaging the paint during fender installation.*
1. Carefully roll the **new** fender forward into position between the rear frame rails.
 2. See Figure 6. Get four 5/16-18 x 25.4 mm (1 in) long fender mounting screws (5) from the kit. Loosely install a screw through the rear frame rail into the rearmost fender mounting boss on each side.
 3. Align the front mounting holes, and loosely install the remaining screws through the frame rails into the forward fender mounting boss on each side.
 4. **Models that previously had OE saddlebag guard RAILS installed:**
 - a. Get the saddlebag guard mounting hardware saved earlier.
 - b. Install either Chrome Saddlebag Support Kit (Part No. 90881-09A) or Genuine Motor Accessory saddlebag guards (Part No. 49179-09, 49282-09B or 49283-09) per the instructions in **THAT** kit. These kits are available separately from a Harley-Davidson dealer.
 5. **ALL models:** Get the two 5/16-18 x 25.4 mm (1 in) long fender mounting screws and flanged locknuts saved earlier. Loosely install the screws, **from the front**, through the saddlebag support or guard lower rear mounting holes and the saddlebag to fender support bracket. Loosely install the flanged locknuts onto the screw threads.
 6. Route the harness leg with the gray four-way connector between the front of the fender and the **left side** fender support. Plug the connector [18] into the left side fascia lamp. Route the harness leg with the black four-way connector between the front of the fender and the **right side** fender support. Plug the connector [19] into the right side fascia lamp.
 7. Alternately tighten the four fender mounting screws to 20.3–27.1 N·m (15–20 ft-lbs).
 8. See Figure 1. **Models with previously installed OE or Genuine Motor Accessory saddlebag supports or guards WITHOUT RAILS:** Install the Torx® head screw at the top rear of the support on each side of the vehicle. Tighten to 20.3–27.1 N·m (15–20 ft-lbs). **ALL models:** Install the rear shock absorber air hose to the air valve assembly on the left side.

9. **FLHTCU/SE models:** Install the chrome fender support covers removed earlier. **ALL models EXCEPT FLHTCU/SE:** See Figure 6. Install the finish painted fender support covers (6) from the kit.
10. Loosely install the front saddlebag mounting bracket and passenger grab strap.
11. Use a cable strap from the kit to fasten a harness leg to the hole on the underside of the fender support cover on each side.
12. Use extra cable straps (not supplied) as needed to tie the harness to the saddlebag support upper bar.

RETURN TO SERVICE

NOTE

*To prevent possible damage to the sound system, verify that the ignition switch is in the OFF position **before** installing the main fuse.*

1. See the service manual. Install main fuse.

SERVICE PARTS

is07233b

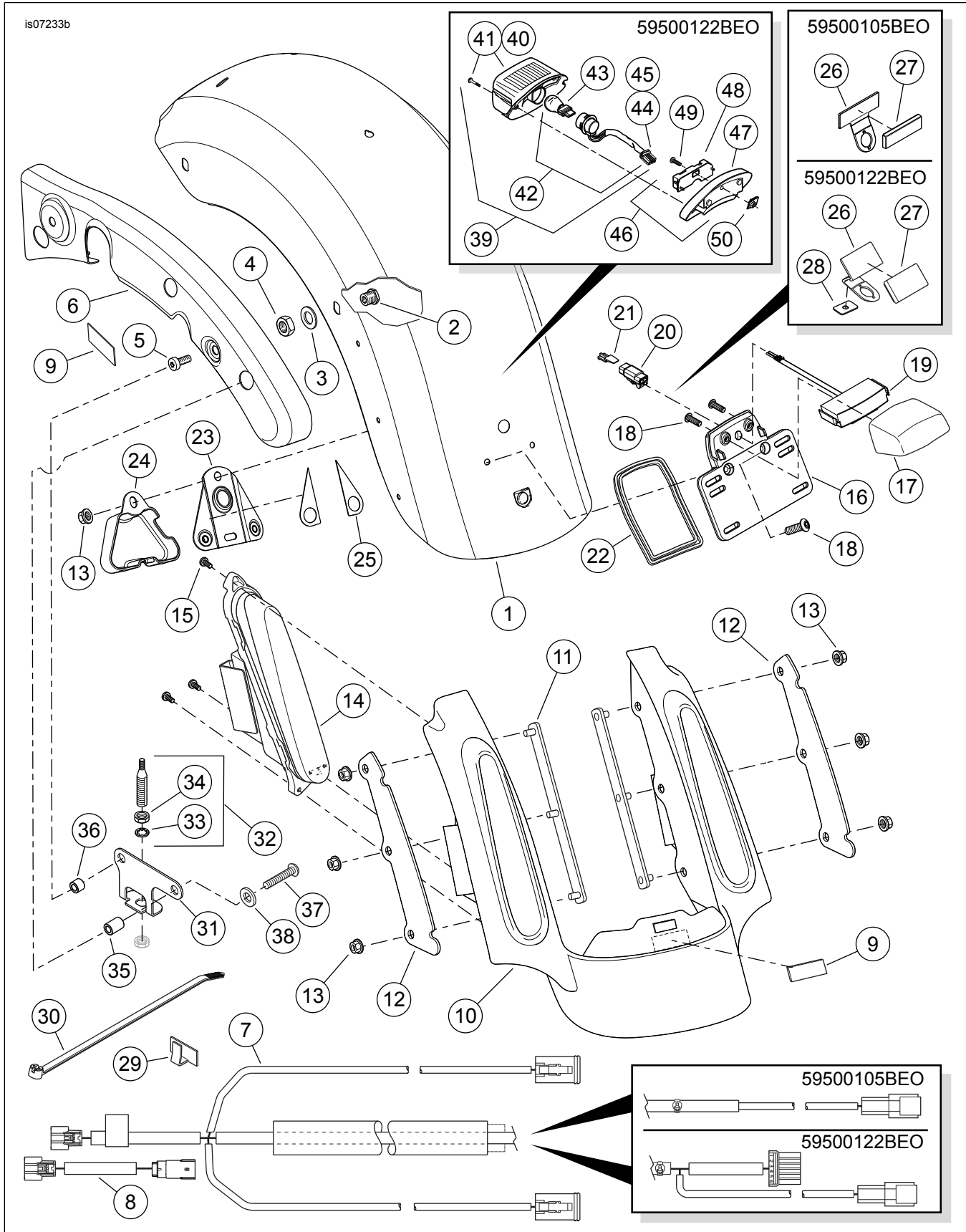

Figure 6. Service Parts, FL Touring CVO-Style Rear Fender Kits

SERVICE PARTS

Table 2. Service Parts

Item	Description (Quantity)	Part Number
1	Fender, rear (Prime paint, no center tail lamp opening) (for Kit 59500105BEO) Fender, rear (Prime paint, with center tail lam opening) (for Kit 59500122BEO)	60463-09A 60472-09A
2	Boss, fender mounting (4)	59786-01
3	Washer, fender mounting (4)	59788-01
4	Hex nut, 1/2-13 (4)	7880
5	Screw, pan head TORX, self-tapping, 5/16-18 x 25.4 mm (1 in) long (4)	3684
6	Fender support cover, right (prime paint) Fender support cover, left (prime paint)	47504-09BDK 47502-09BDK
7	Harness, rear lighting (for Kit 59500105BEO) Harness, rear lighting (for Kit 59500122BEO)	70338-09 70450-09
8	Jumper, rear lighting to vehicle main harness (eight-way socket housing one end) Jumper, rear lighting to vehicle main harness (six-way pin housing one end)	69200478 69200532
9	Spacer, rubber, adhesive-backed, 44.5 x 19 x 1.6 mm (x in) (3)	11891
10	Fascia, rear fender (unpainted)	60465-09
11	Stud plate (2)	59818-09
12	Fascia support bracket (2)	60919-09
13	Large flange nut, 1/4-20 (7)	7499
14	LED stop/tail/turn signal lamp assembly (Red, with Smoke lens), right (for Kit 59500105BEO) LED stop/tail/turn signal lamp assembly (Red, with Smoke lens), left (for Kit 59500105BEO) LED turn signal lamp assembly (Amber), right (for Kit 59500122BEO) LED turn signal lamp assembly (Amber), left (for Kit 59500122BEO)	69407-09A 69383-09A 69518-09B 69496-09B
15	Screw, pan head TORX, black, #10 x 12.7 mm (0.5 in) long (6)	3152
16	Bracket, license plate	60915-09A
17	Cover, license light (unpainted)	60934-10
18	Screw, 1/4-20 x 19 mm (0.75 in) (4)	940
19	Light, license plate	60920-09
20	Socket housing, 2-way, black	74112-98BK
21	Secondary lock	74152-98
22	Gasket, upper license plate	57637-09
23	Stud plate	59840-09
24	Connector cover	60916-09
25	Foam pad, adhesive-backed, license plate bracket (2)	11100008
26	Bracket, reflector (for Kit 59500105BEO) Bracket, reflector (for Kit 59500122BEO)	60922-09 60921-09
27	Reflector (for Kit 59500105BEO), 73 x 22 mm (x in) Reflector (for Kit 59500122BEO), 69 x 32 mm (x in)	59359-06 59259-90
28	Pad, rubber, adhesive-backed, 30 x 19 x 1.6 mm (x in)	6549
29	Clip, adhesive-backed (2)	10102
30	Cable strap (2)	10006
31	Antenna bracket, rear	76555-09
32	Antenna base assembly (includes items 33-34)	76335-87
33	• Lock washer	7129
34	• Nut (2)	76259-86
35	Spacer, antenna, front	12400030
36	Spacer, antenna, rear	12400031
37	Screw, button head TORX, 5/16-18 x 41.3 mm (1.62 in) long, Grade 8 (2)	3148
38	Flat washer (2)	6702
Items used in kit 59500122BEO only:		
39	Light assembly, tail lamp (includes items 40-45)	68142-04
40	• Lens, tail lamp (includes item 41)	68558-03
41	• Screw, tail lamp (2)	68026-99
42	• Bulb and socket assembly, tail lamp (includes item 43-45)	69187-03A
43	• Bulb, tail lamp, wedge mount	68167-04
44	• Socket housing, four-way	73154-96BK
45	• Socket terminal, #16-20 AWG (3)	73191-96
46	Tail lamp base assembly (includes items 47-48)	68066-99A
47	• Tail lamp base (chrome)	68296-99A

Table 2. Service Parts

Item	Description (Quantity)	Part Number
48	• Circuit board and cover	68830-99A
49	Screw, socket head, 1/4-20 x 16 mm (5/8 in) long	3022A
50	J-nut	7964