



INSTRUCTIONS

J06254

2016-02-18



HANDLEBAR SWITCH CAP KITS

GENERAL

Kit Number

71500441

Models

These kits contain complete sets of switch caps for the left and right handlebar switches. These caps are direct replacements for the standard equipment black switch caps.

Additional Parts Required

Ask your Harley-Davidson Dealer about Switch Housing kits and Hand Lever Bracket kits, and the selection of Handlebar Grips that are also available for these models. These items can be easily installed at the same time as this kit.

⚠ WARNING

Rider and passenger safety depend upon the correct installation of this kit. Use the appropriate service manual procedures. If the procedure is not within your capabilities or you do not have the correct tools, have a Harley-Davidson dealer perform the installation. Improper installation of this kit could result in death or serious injury. (00333b)

NOTE

This instruction sheet references service manual information. A service manual for your model motorcycle is required for this installation and is available from a Harley-Davidson dealer.

Kit Contents

See Figure 3 and Table 1.

REMOVAL

1. Open or remove seat according to the instructions in the service manual.

⚠ WARNING

To prevent accidental vehicle start-up, which could cause death or serious injury, disconnect battery cables (negative (-) cable first) before proceeding. (00307a)

⚠ WARNING

Disconnect negative (-) battery cable first. If positive (+) cable should contact ground with negative (-) cable connected, the resulting sparks can cause a battery explosion, which could result in death or serious injury. (00049a)

⚠ WARNING

To prevent accidental vehicle start-up, which could cause death or serious injury, remove main fuse before proceeding. (00251b)

2. Disconnect the negative (-) battery cable or remove the main fuse.
3. Remove left and right side switch housing assemblies. Refer to the service manual.

NOTE

It is not necessary to disconnect the switch wiring to replace the switch caps.

4. Remove individual switches from switch housing. Refer to the service manual.

INSTALLATION

Upper Housing Switches

1. See Figure 1 and Figure 3. Carefully pry stock black switch cap up off the pivot pin shaft (2) on left side of switch.

NOTE

Be aware there are small pins and springs under some of the caps. Use caution when removing caps. Springs and pins could be lost during cap removal or installation.

2. Pry the switch cap up and away from pivot pin (3) on right side of switch. Remove cap.
3. See Figure 3. Select proper replacement switch cap from kit.
4. See Figure 1. Place cap onto switch, angling the hole on right side over pivot pin (4) on switch.
5. Carefully press switch cap down onto left side pivot pin (5), rocking and moving the cap until shaft snaps into place.
6. Toggle switch back and forth, checking for proper operation.



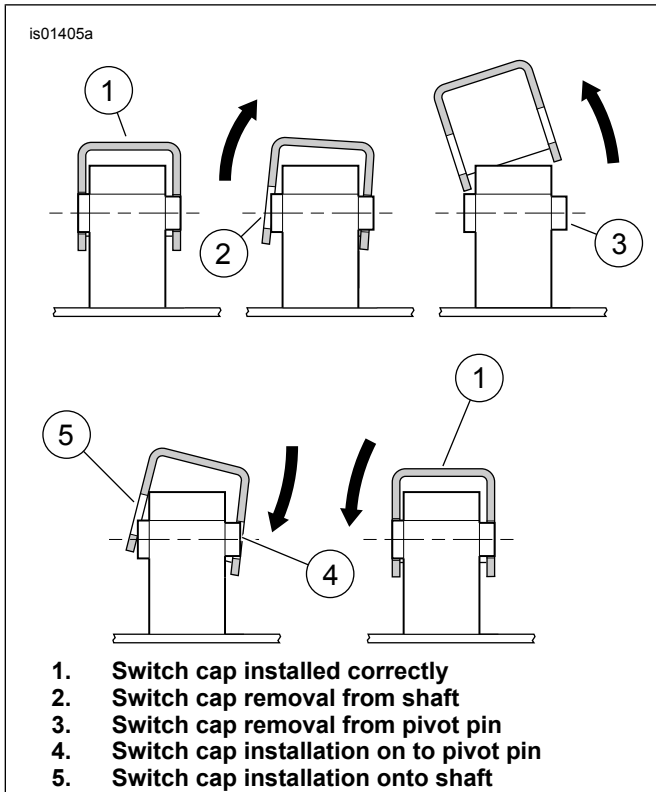

Figure 1. Switch Cap Removal and Replacement

Turn Signal Switches

1. See Figure 1 and Figure 3. Carefully pry stock black switch cap up off one of the pivot pins on switch.
2. Pry the switch cap up and away from the other pivot pin (3) on switch. Remove cap.
3. Select proper replacement switch cap from kit.
4. See Figure 1. Place cap onto switch, angling the hole on top over pivot pin (4) on switch.
5. Carefully press switch cap onto other pivot pin (5), rocking and moving the cap until shaft snaps into place in the hole.
6. Toggle switch back and forth, checking for proper operation.

Assemble Switches

1. Assemble switches back into switch housings. Use care when installing switches to avoid damage. Refer to the service manual.

2. Assemble left and right side switch housing assemblies. Refer to the service manual.

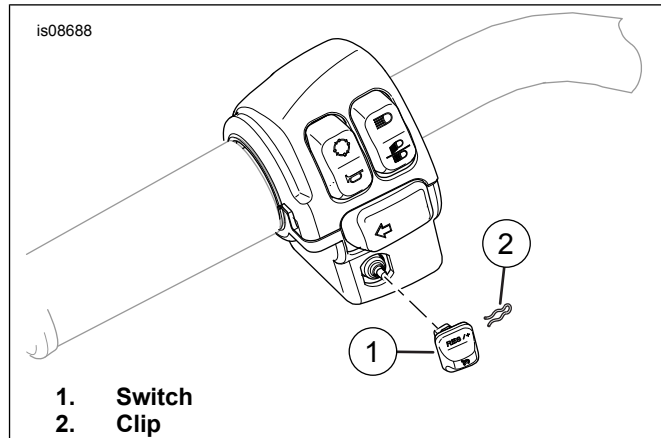

Figure 2. Cruise Switch

3. See Figure 2. For models equipped with cruise control, install cruise control switch (1) and clip (2).

⚠ WARNING

Connect positive (+) battery cable first. If positive (+) cable should contact ground with negative (-) cable connected, the resulting sparks can cause a battery explosion, which could result in death or serious injury. (00068a)

4. Connect battery cables, positive (+) cable first or install the main fuse.

⚠ WARNING

After installing seat, pull upward on seat to be sure it is locked in position. While riding, a loose seat can shift causing loss of control, which could result in death or serious injury. (00070b)

5. Install seat according to the instructions in the service manual.
6. Test all the handlebar switches for proper operation.

SERVICE PARTS

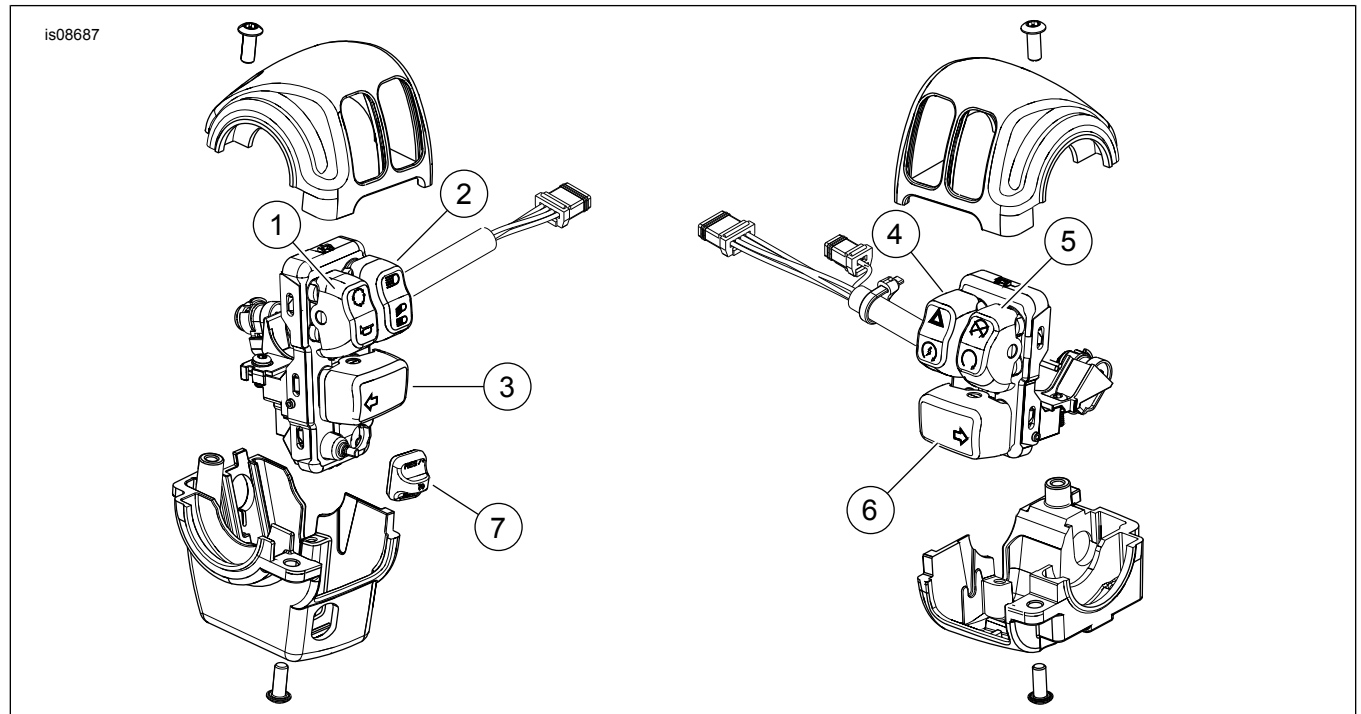

Figure 3. Service Parts: Handlebar Switch Caps

Table 1. Service Parts: Handlebar Switch Caps

Item	Description (Quantity)	Part Number
1	Switch cap, HORN	Not Sold Separately
2	Switch cap, LIGHTS HI/LO	Not Sold Separately
3	Switch cap, left turn arrow	Not Sold Separately
4	Switch cap, START	Not Sold Separately
5	Switch cap, OFF/ENGINE STOP/RUN	Not Sold Separately
6	Switch cap, right turn arrow	Not Sold Separately
7	Switch cap, cruise	Not Sold Separately