



INSTRUCTIONS

J05789

2014-07-30



BOOM! SECONDARY AUDIO AMPLIFIER EXPANSION KIT

GENERAL

Kit Number

76000280

Models

For model fitment information, see the P&A Retail Catalog or the Parts and Accessories section of www.harley-davidson.com (English only).

Installation Requirements

Prior or concurrent installation of a fairing-mounted amplifier is required for proper installation of this kit. See the P&A retail catalog or the Parts and Accessories section of www.harley-davidson.com (English only) for Audio Amplifier Kit part numbers and fitments.

In these instructions: the Harman-Kardon® amplifier (fairing mount) is considered the "primary" amplifier. The saddlebag-mounted amplifier is referred to as the "secondary" amplifier.

FLHTKSE and FLTRUSE models require separate purchase of 69200714.

This kit is not compatible with premium bag liners. Fitted saddlebag linings require trimming to accommodate amplifier mount and harness cover.

⚠ WARNING

Rider and passenger safety depend upon the correct installation of this kit. Use the appropriate service manual procedures. If the procedure is not within your capabilities or you do not have the correct tools, have a Harley-Davidson dealer perform the installation. Improper installation of this kit could result in death or serious injury. (00333b)

NOTE

This instruction sheet references service manual information. A service manual for this year/model motorcycle is required for this installation and is available from a Harley-Davidson dealer.

The purchase of this kit entitles you to a specially developed sound equalization software that is used in conjunction with the Advanced Audio System. This unique equalization was designed to optimize the performance and sound response of the BOOM! Audio fairing lower speakers. Even if this kit is not installed by a Harley-Davidson dealer, this special equalization software is available without charge from any dealer through Digital Technician II. Dealer labor rates may apply for the upgrade procedure.

Electrical Overload

NOTICE

It is possible to overload the vehicle's charging system by adding too many electrical accessories. If the combined electrical accessories operating at any one time consume more electrical current than the vehicle's charging system can produce, the electrical consumption can discharge the battery and cause damage to the vehicle's electrical system. (00211d)

⚠ WARNING

When installing any electrical accessory, be certain not to exceed the maximum amperage rating of the fuse or circuit breaker protecting the affected circuit being modified. Exceeding the maximum amperage can lead to electrical failures, which could result in death or serious injury. (00310a)

The amplifier installed with this Amplifier Expansion Kit requires up to **8 amps** additional current from the electrical system.

Kit Contents

See Figure 14 and Table 2.

PREPARATION

NOTE

For vehicles equipped with security siren:

- Verify that the hands-free Fob is present.
 - Turn ignition switch ON.
1. See the service manual. Follow the instructions to remove the fuel tank, top caddy, left side caddy and left side cover. FLHX and FLTRX models may require removal of outer fairing depending on speaker and amplifier configuration.
 2. See Figure 1. Remove the wire trough cover.





Figure 1. Wire Trough

INSTALLATION: GENERAL (ALL MODELS)

NOTE

This system is designed to work with Boom! Audio speakers only. Any original equipment (OE) speakers must be removed.

Verify that the primary amp is installed per the instruction sheet shipped with that kit.

- **Simultaneous Installation:** Route the wire harness (69200487) from the primary amp kit. Make all electrical connections except stock OE [162] and/or primary amp output [313].
- **Upgrade Installation:** Disconnect any 4-way connectors at [313] and [162]. This may include fairing lower speakers, saddlebag cover speakers or rear pods speakers. Disconnect only the 4-way portion of any rear speaker pods. Those connections may be made at stock OE [162] and/or primary amplifier output [313]. Speaker connections at [162] and [313] will be addressed in the wire harness section of the install.

1. See the service manual. Remove the left saddlebag. If any bag liners are present, remove them.
2. See Figure 2. Place the left saddlebag on a protected surface with mounting side face up. Use the template to cut the opening for the saddlebag amp [288].
 - a. With a hobby knife or scissors, cut opening for connector marked by the dotted line on the template.
 - b. Place template on saddlebag, align the grommet and latch fasteners and trace the cut outline for connector. If cover speakers are present from previous install, LH speaker wires will be in this location. Remove the wire and grommet.
 - c. Center punch two locations for the 9/32 drill.
 - d. Verify size of opening with pin side connector from wire harness (69200488).
 - e. Cut opening for connector.
 - f. Place masking tape over the two locations for the screw holes. Drill two 9/32 holes.

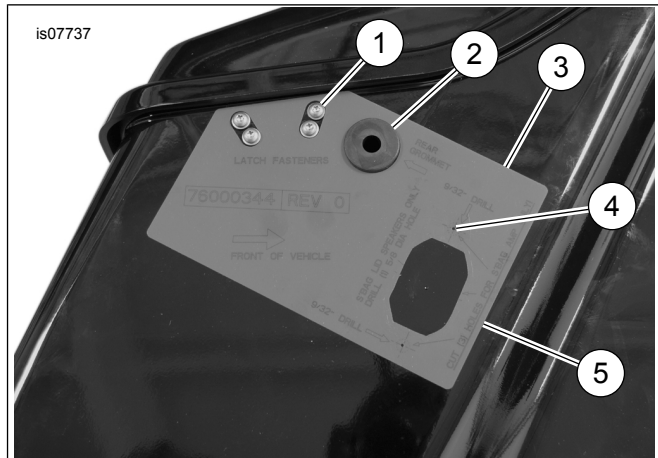

1. Latch fasteners
2. Grommet
3. Template
4. Screw hole location
5. Connector cut-out and hole location

Figure 2. Cut Connector Opening

3. See Figure 3. Install pin side connector of jumper harness (item 10, Figure 14) from inside the saddlebag. Secure connector with two screws and washers.

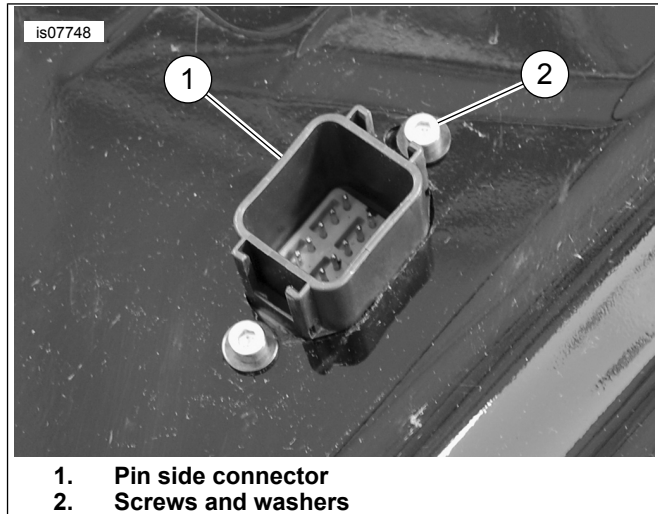

1. Pin side connector
2. Screws and washers

Figure 3. Pin Side Connector

4. See Figure 4. Snap the harness cover over the connector. Secure with a cable strap. The harness routes inside the saddlebag after the amplifier is mounted.

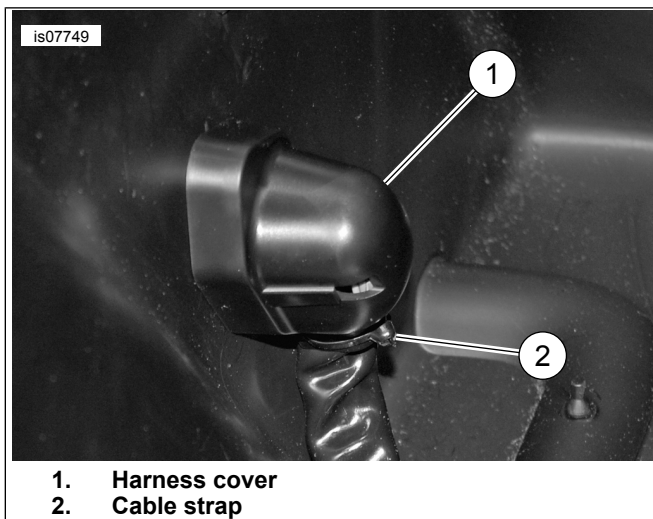

- 1. Harness cover
- 2. Cable strap

Figure 4. Harness Cover

5. See Figure 5. Clean the inside rear and bottom surfaces of the saddlebag with a mixture of 50-70 percent isopropyl alcohol and 30-50 percent distilled water. Remove the four pieces of protective backing from the amplifier bracket tape strips and position as shown.

NOTE

Verify that all four pieces of tape are contacting the saddlebag.

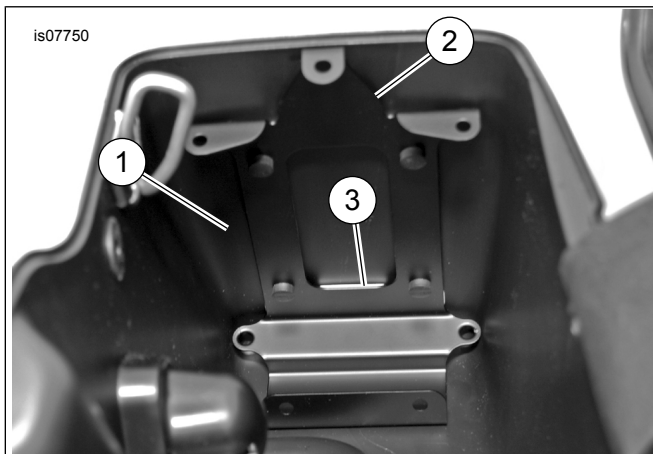

- 1. Area to be cleaned
- 2. Amplifier bracket
- 3. Tape strips

Figure 5. Amplifier Bracket Installation

6. See Figure 6. Install the amplifier pin studs in the amplifier. Tighten to 9.4–12.2 N·m (7–9 ft-lbs). Install the grommets.

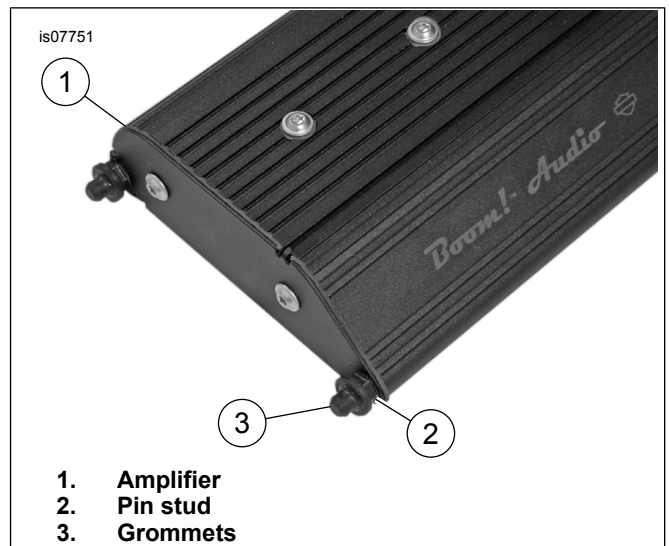

- 1. Amplifier
- 2. Pin stud
- 3. Grommets

Figure 6. Amplifier Pin Studs

7. See Figure 7. Position the amplifier with the grommets in the holes in the bottom of the amplifier bracket and slide the top into the bracket. Install the 2 hex socket button head screws. Tighten to 9.4–12.2 N·m (7–9 ft-lbs).



- 1. Amplifier
- 2. Hex socket button head screws

Figure 7. Amplifier Installation

8. See Figure 8. Clean the inside bottom and side surfaces of the saddlebag with a mixture of 50-70 percent isopropyl alcohol and 30-50 percent distilled water. Connect the amplifier end of harness (69200488) and route the saddlebag side harness inside the left saddlebag. Secure with cable straps and bases as shown.

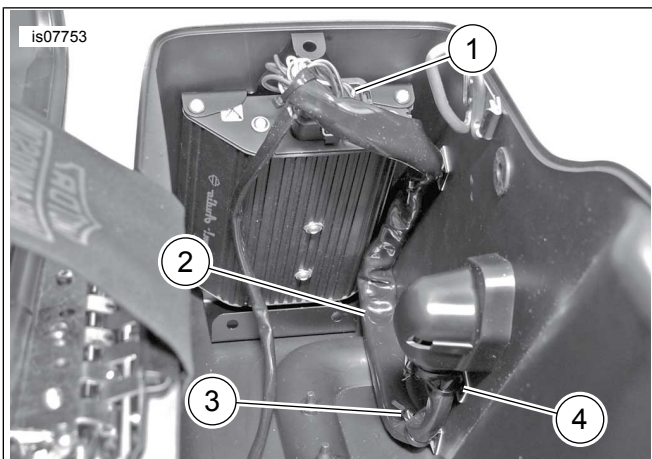

1. Amplifier harness connector
2. Wire harness
3. Wire harness cable strap
4. Wire harness

Figure 8. Inner Harness Routing

9. See Figure 9. Clean the inside top surfaces of the saddlebag with a mixture of 50-70 percent isopropyl alcohol and 30-50 percent distilled water. Route the saddlebag speaker harness inside the left saddlebag leaving enough slack to open the cover. Secure with cable straps and bases as shown. If cover speakers are not used, bundle the unused wire next to amplifier on the outboard side. Secure with cable strap and base.

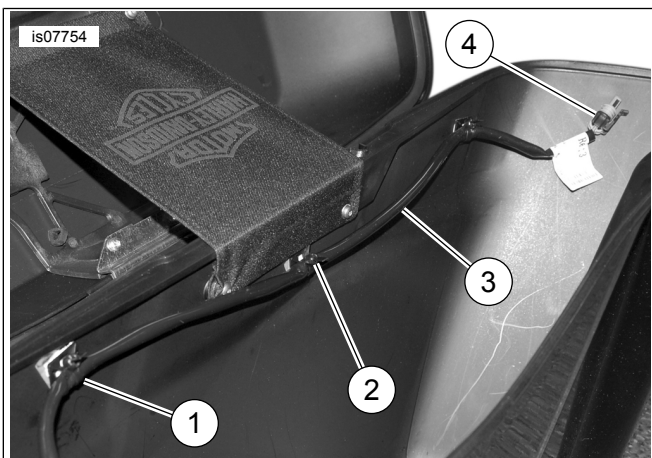

1. Cable strap
2. Cable strap base
3. Wire harness
4. Speaker connector

Figure 9. Speaker Harness Routing

10. **Saddlebag liners:** Trim saddlebag liners. Install saddlebag liners.
11. See Figure 10. Install the amplifier cover on the bracket. Secure with three christmas tree fasteners.

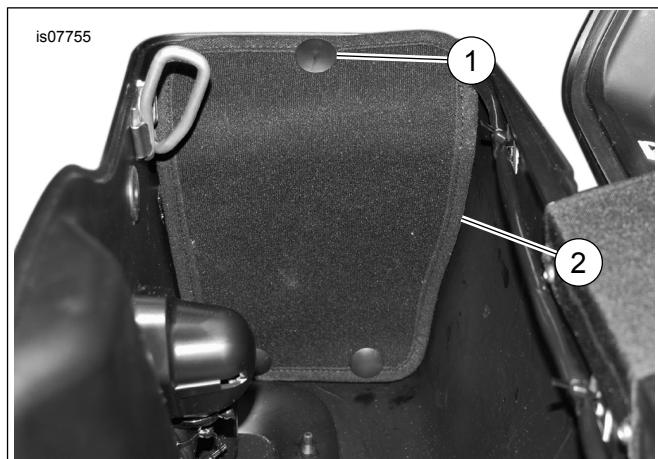

1. Christmas tree fasteners
2. Amplifier cover

Figure 10. Amplifier Cover

Left-Side Saddlebag, Amplifier Harness Installation

1. See the service manual. Remove the left side cover and left side caddy.
2. See Figure 11. Release the stock [91A] from the left side caddy. Pull it back through the opening into the area behind the caddy, under the seat.

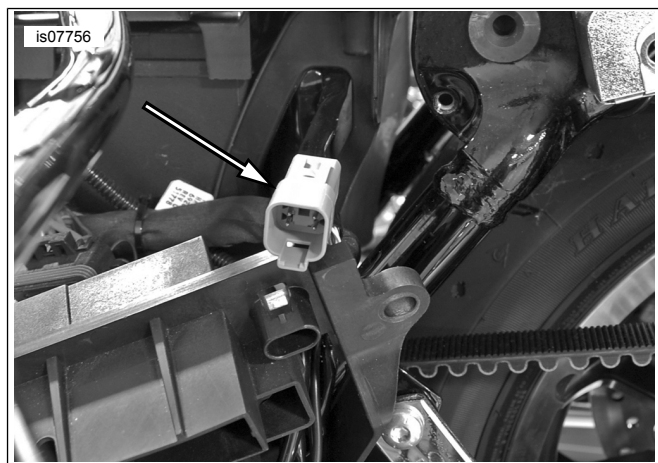

Figure 11. DLC [91A]

3. Remove the weather cap from the stock [91A]. Connect that [91A] to [91B] of harness (69200490). Place the weather cap from the stock connector on [91A] of harness (69200490).
4. Route [91A] of harness (69200490) back through left side caddy to original location. Secure it to the caddy using original clip.
5. See the service manual to install the left side caddy.
6. See the service manual to remove the top caddy.
7. Route the battery terminal branch to the battery terminals.
 - a. Remove the - and + battery terminals.

- b. Position the + ring terminal on the positive battery terminal, install the bolt.
 - c. Position the - ring terminal on the negative battery terminal, install the bolt. Tighten both bolts to 6.8–7.9 N·m (60–70 **in-lbs**).
 - d. Position the in-line fuse holder in a location that can be easily accessed.
8. See Figure 12. Route [288] under the fender support and behind shock under fender strut, through opening between frame and fender. Secure with cable straps as shown. Secure the amplifier harness to the main harness with a cable strap. Make sure that cable routing is sufficient to account for full travel of the rear suspension.

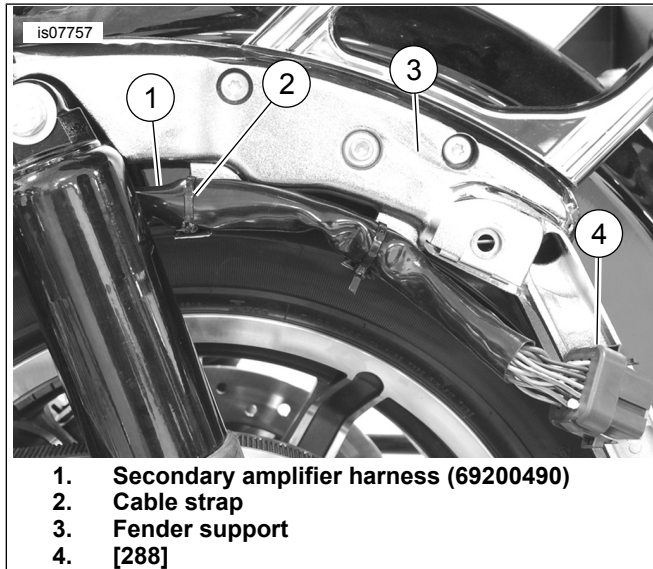

Figure 12. Harness Routing

HARNES ROUTING

1. See Figure 13.
 - Connect RADIO rear channel output [162] to input of secondary amplifier at [296] of 69200490.
 - **FLHX and FLTRX models:** Use jumper (69200489) to connect stock harness [162] located under fairing, to connect to [296] of (69200490). Route jumper in wire trough.
 - Upgrade: If this installation is an upgrade from a prior install of saddlebag cover speakers or rear pods, then the jumper (69200489) should already be installed.
 - If the jumper (69200489) is connected from the primary amp at [313] to covers or rear pods, then disconnect them from the primary amp at [313].
 - If the jumper (69200489) is connected to [162] in the fairing, then leave it in place. Disconnect the other end from the cover speakers or rear pods.
 - Connect pin side of jumper (69200489) to socket side connector [296] of (69200490). Install wire trough cover.
 - **FLHTCU and FLHTK:** Use Rear Speaker Interconnect (69200714) located behind the passenger backrest flap to connect to [296] of (69200490).

- Upgrade: If jumper (69200489) is connected from the primary amplifier [313] to the Rear Speaker Interconnect (69200714), then disconnect both 4-way ends of the jumper. Discard jumper.
- Connect the 4-way pin side of the Rear Speaker Interconnect (69200714), installed with primary amplifier, to the mating 4-way socket side [296] of (69200490). Install wire trough cover if removed.
- **FLHTKSE and FLTRUSE models:** Requires separate purchase of (69200714). Insert 69200714 between the 16-way sides between connector [162A and B] located under the passenger backrest flap. Locate [296] on the vehicle harness (near rear lighting connector 7) and remove cap. Connect 4-way pin side of connector [296] to the (input) socket side of (69200490) [296].

2. Connect Rear Speaker Pod Output: Use pin side connection [297] from secondary amplifier harness (69200490); to 4-way socket side connector of the rear pods. **FLHX and FLTRX models:** Connect rear speaker pods to [297] of (69200490) (if equipped). Cap [297] if not used. **FLHTCU and FLHTK:** Connect the 4-way socket side of (69200714) to the mating 4-way pin side of (69200490) at [297]. **FLHTKSE and FLTRUSE models:** Connect the 4-way socket side of (69200714) to the mating 4-way pin side of (69200490) at [297]. Cap the unused 4-way pin side of (69200714) with the cap from the vehicle connector. Do not connect the 4-way pin side of rear Speaker Interconnect to [296] of 69200490.

3. Connect Saddlebag Cover Speaker Output: Use 2-way pin side connection [298] from secondary amplifier harness (69200490) to 2-way socket side connector (if equipped).

- a. RH side: Connect 2-way pin side connector of secondary amplifier output [298] to RH 2-way saddlebag cover speaker harness (69200641). Connector location is shown in the saddlebag cover kit. Saddlebag cover speaker harness (69200642) provided with cover speaker kit will not be used with this kit. Upgrade: If speaker covers are already present from a prior install, remove the "Y" harness (69200642). Connector [298] on (69200490) will replace it for the RH saddlebag.
- b. The LH cover speaker connection is made inside the LH saddlebag as part of the (69200488) harness. See figure 9. Upgrade: If cover speakers are present from a prior install, remove the harness (69200641) from inside the LH saddlebag. The 2-way connector provided with harness (69200488) will replace it.

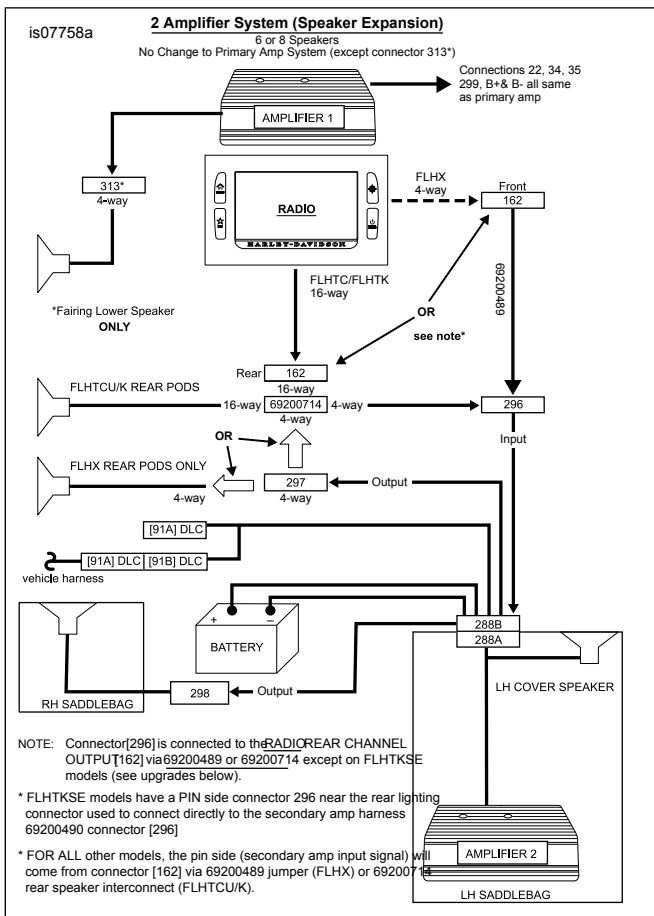

Figure 13. Amplifier System

4. Secure with harness with cable straps and install the wire trough.
5. See the service manual to install the LH side cover.
6. Place the LH saddlebag on the supports. Tip the top of the bag out to get behind it and connect the mating sides of the 18-way [288]. It is keyed so it can only go in one way. There will be a "click" when fully seated. Finish installing the LH side saddlebag.
7. Cap any unused 4-way pin-side connectors with (72632-10) provided with (692000478) and [313] or from stock vehicle at [162].
8. Locate unused speaker connectors and additional wire length under the seat. It may be a good idea to label unused connectors with tape in case of future upgrades.
9. If fairing lower speakers are used, connect the 4-way socket side from the harness provided with that kit to [313] of the primary amplifier.

⚠ WARNING

Be sure that steering is smooth and free without interference. Interference with steering could result in loss of vehicle control and death or serious injury. (00371a)

10. Make sure that the harness does not interfere with steering or movement of the front suspension. Secure with cable straps.

COMPLETION

NOTE

ALL Models: To prevent possible damage to the sound system, verify that the ignition key switch is in the OFF position before installing the main fuse.

1. See the service manual. Install the main fuse.
2. Turn the ignition key switch to IGNITION, but do not start the motorcycle.
3. Test the radio and speaker controls for proper operation.
4. After the test is complete, disconnect the main fuse. Install the fuel tank per service manual instructions.
5. See the service manual. Install the outer fairing and windshield.

⚠ WARNING

After installing seat, pull upward on seat to be sure it is locked in position. While riding, a loose seat can shift causing loss of control, which could result in death or serious injury. (00070b)

6. See the service manual. Install seat.

NOTE

Digital Technician is available only at Harley-Davidson dealers.

7. Load amplifier EQ based on speaker configuration using amplifier flash section of Dealer Service Tool (Digital Technician). **Amplifier application software/firmware: Amplifier and speaker EQ configuration:**
 - a. Check for updates to the amplifier base calibration (firmware).
 - b. Install latest version of base calibration, if updates are available.
 - c. Proceed to radio reflash and select speaker configuration.
 - d. Select the correct EQ based on the speaker configuration found in the information section.
 - e. Complete the reflash of the radio with the new speaker configuration.
 - f. Proceed to amplifier reflash.
 - g. Load amplifier EQ based on speaker configuration as noted in the radio reflash section.
 - h. Complete amplifier reflash.

Table 1. Connector Table for Secondary Amplifier Harness (69200490)

Connector	Description
[288]	18-way saddlebag connector
[296]	Secondary amplifier input (from radio rear channel)

Table 1. Connector Table for Secondary Amplifier Harness (69200490)

Connector	Description
[297]	Rear speaker pod output
[298]	Right saddlebag cover speaker output

SERVICE PARTS

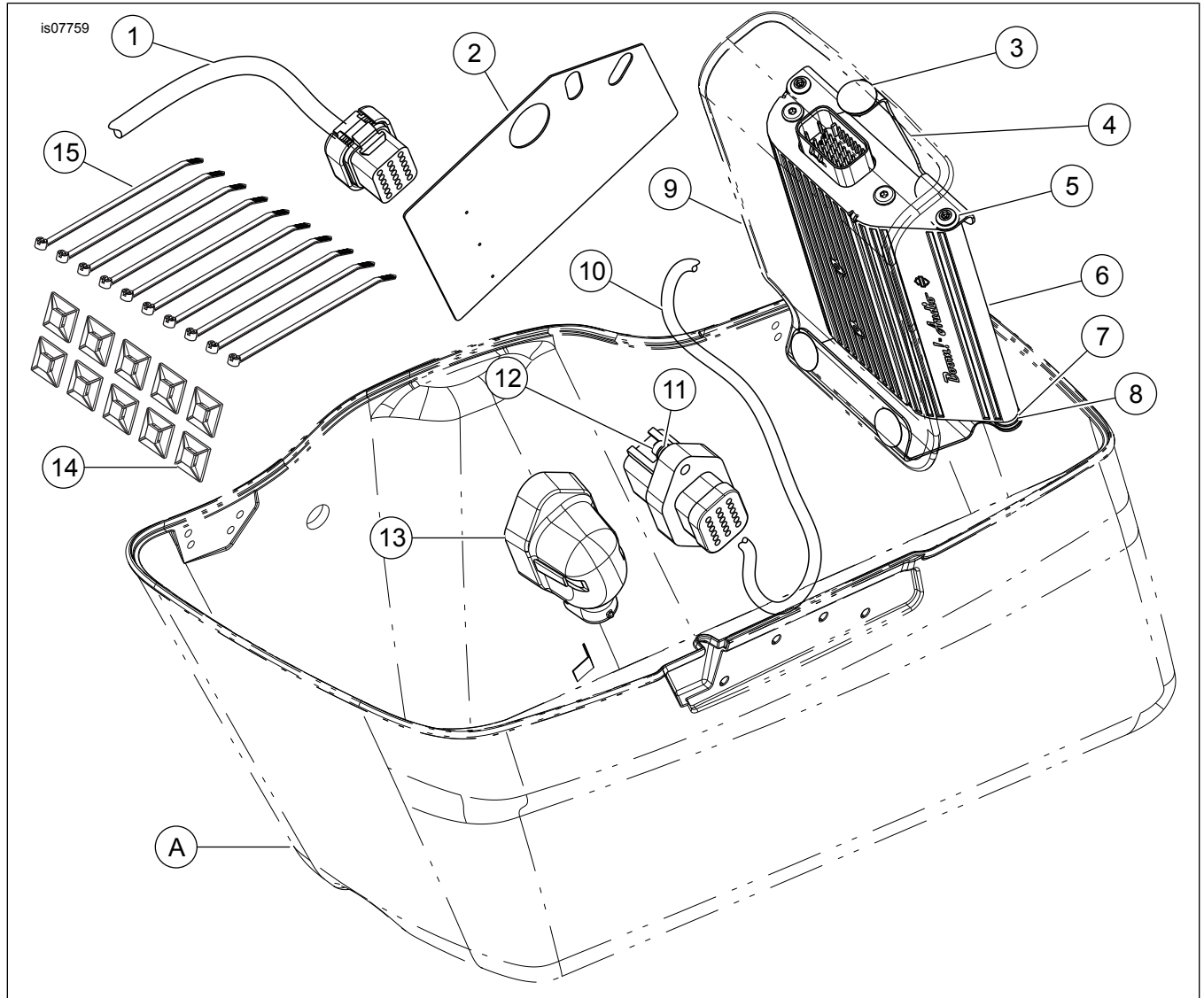

Figure 14. Service Parts, Boom! Audio Amplifier Expansion Kit

Table 2. Service Parts Table

Item	Description (Quantity)	Part Number
1	Secondary amplifier wire harness (marked 69200490)	Not Sold Separately
2	Drill template	76000344
3	Amp clip (3)	12600068
4	Saddlebag amplifier bracket	76000282A
5	Hex socket button head screws (2)	926
6	Amplifier	76000277
7	Stud pin (2)	12600087
8	Amplifier grommet (2)	12100052
9	Saddlebag amplifier cover	Not Sold Separately
10	Saddlebag amplifier jumper wire harness (marked 69200488)	Not Sold Separately
11	M5 Flat washer (2)	6454
12	M5 Socket head cap screw (2)	3798M
13	Plug cover	Not Sold Separately

Table 2. Service Parts Table

Item	Description (Quantity)	Part Number
14	Cable strap base (10)	69200342
15	Cable strap (10)	10006
Items mentioned in text, but not included in kit:		
A	Saddlebag	