



# INSTRUCTIONS

J05624

2014-06-20



## SADDLEBAG SPOILER AND AUXILIARY REAR LIGHT KIT

### GENERAL

#### Kit Numbers

90200735, 90200736

#### Models

For model fitment information, see the P&A retail catalog or the Parts and Accessories section of [www.harley-davidson.com](http://www.harley-davidson.com) (English only).

#### Installation Requirements

Purchase a color-matched Saddlebag Lid Spoiler Cover Set (Part No. 57200087xxx) to complete this installation. This item is available separately from a Harley-Davidson dealer.

#### ⚠ WARNING

Rider and passenger safety depend upon the correct installation of this kit. Use the appropriate service manual procedures. If the procedure is not within your capabilities or you do not have the correct tools, have a Harley-Davidson dealer perform the installation. Improper installation of this kit could result in death or serious injury. (00333b)

#### NOTE

This instruction sheet refers to service manual information. A service manual for this year/model motorcycle is required for this installation. One is available from a Harley-Davidson dealer.

### ELECTRICAL OVERLOAD

#### NOTICE

It is possible to overload the vehicle's charging system by adding too many electrical accessories. If the combined electrical accessories operating at any one time consume more electrical current than the vehicle's charging system can produce, the electrical consumption can discharge the battery and cause damage to the vehicle's electrical system. (00211d)

#### ⚠ WARNING

When installing any electrical accessory, be certain not to exceed the maximum amperage rating of the fuse or circuit breaker protecting the affected circuit being modified. Exceeding the maximum amperage can lead to electrical failures, which could result in death or serious injury. (00310a)

This kit requires up to 256 mA more current from the electrical system.

#### Kit Contents

See Figure 4 and Table 1.

### PREPARATION

#### ⚠ WARNING

To prevent accidental vehicle start-up, which could cause death or serious injury, remove main fuse before proceeding. (00251b)

#### NOTE

- **WITH security siren:** With security fob present, turn ignition switch ON. See the service manual. After system is disarmed, turn ignition OFF. **IMMEDIATELY** remove the main fuse.
- **WITHOUT security siren:** See the service manual. Remove main fuse.

1. **ALL models:** See the service manual. Remove seat.
2. Remove left saddlebag. Remove left side cover.

### INSTALLATION

#### Drill Spoiler Mounting Holes

1. See the service manual. Remove saddlebag cover with latch assembly. Remove latch assembly from saddlebag cover.
2. Lay masking tape on the saddlebag cover **outer** surface in the spoiler installation area.
3. See Figure 4. Get the template (12) from the kit.

#### NOTE

The template is used for both saddlebag covers. See Figure 1 for placement in left cover. Flip the template over for use in right cover.

4. **Models with original equipment (OE) saddlebag covers:** Models with BOOM! speaker saddlebag covers:
  - a. See Figure 1. Orient the template (1) on the inside of the saddlebag cover, with the arrow (2) pointing toward the latch side of the cover as shown.
  - b. Position the template by aligning the three template holes (3) with the corresponding circles molded into the cover.
    - a. See Figure 1. Orient the template (1) on the inside of the saddlebag cover, with the arrow (2) pointing toward the latch side of the cover as shown.
    - b. Position the template by aligning the perimeter (4) with the interior shape of the cover. Align the notched edge (5) with the rearmost edge of the rectangular outline molded into the cover.
    - c. Verify that the perimeter of the template evenly follows the interior shape of the cover. Make any necessary adjustments.



5. **ALL saddlebag covers:** Tape the template in place.
6. Mark two locations "M" for the spoiler base mounting screw holes. Mark the location "W" for the spoiler wiring hole. Remove the template.
7. Drill a 3 mm (1/8 in) diameter hole at the center of each marked location.
8. From **outside**, enlarge the two spoiler base mounting screw holes (6) to 6.5 mm (1/4 in) diameter.
9. Enlarge the wiring hole (7) to 9.5 mm (3/8 in) diameter.
10. Remove the masking tape. Lightly sand the holes to remove burrs and sharp edges. Clean the saddlebag cover with a 50-50 mixture of isopropyl alcohol and distilled water. Allow to dry completely.
11. Remove right saddlebag. Remove right side cover. Repeat Steps 1-10 for the right saddlebag.

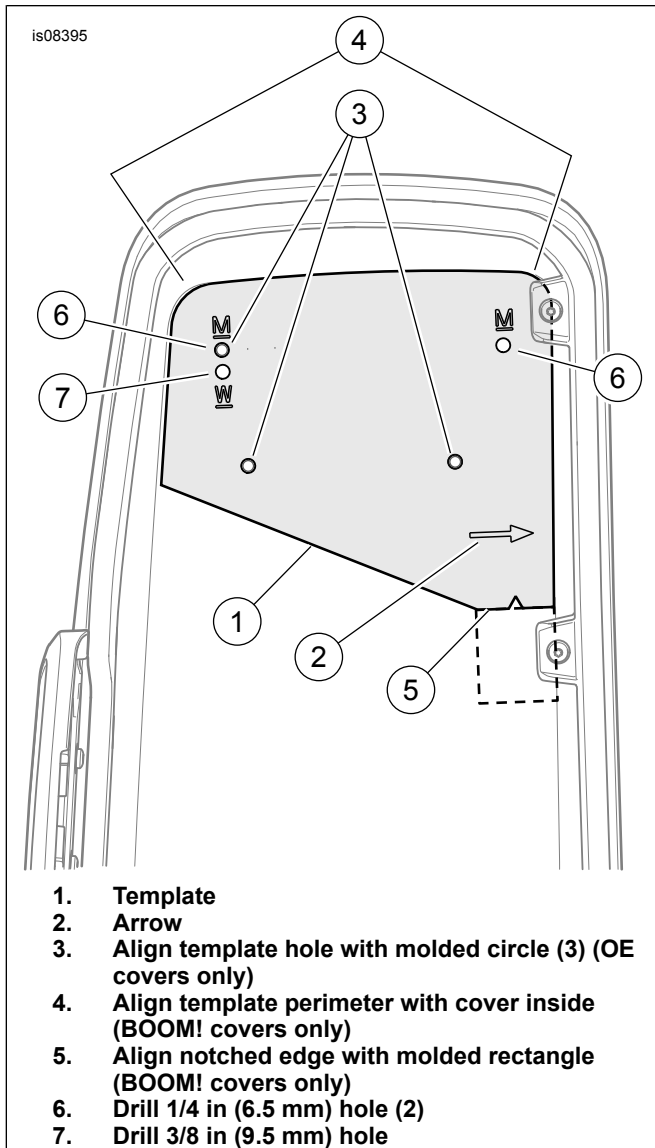

Figure 1. Drill Holes in Saddlebag Cover (Left Shown)

## Install Spoiler

1. Get one spoiler base, and an auxiliary light assembly (1) from the kit. Feed the light wiring through the correct base wiring hole to align with the wiring hole drilled in the saddlebag cover.
2. Position the light assembly with the bottom lip against the front edge of the spoiler base. Align the mounting ears with the base screw holes.
3. Get a spoiler cover (A, purchased separately). Install the cover over the spoiler base and light assembly. Make sure that the wires are not pinched.

### NOTE

**DO NOT** apply liquid threadlocker to the screws.

4. Assemble the base and light to the cover with two button head socket cap screws (5) as shown, but do not fully tighten. Tighten the two screws incrementally to 0.7–0.9 N·m (6–8 in-lbs).
5. Get a gasket pair sheet (6) from the kit. Cut along the dashed line to separate the pair. **Do not** remove the protective tape from the adhesive backing now.

### NOTE

Identify left and right gaskets by matching them to the spoiler base with the protective tape facing the base.

6. Get the gasket for the wiring side of the spoiler.
  - a. Feed the wiring through the **larger** hole in the gasket.
  - b. While holding the gasket in position against the base, peel the protective tape from the corner nearest the wire. Apply that corner to the base.
  - c. Remove the rest of the protective tape. Adhere the rest of the gasket to the spoiler base.
  - d. Repeat with the remaining gasket on the opposite end of the spoiler base.
7. Feed the spoiler wiring through the saddlebag lid. Install the spoiler to the lid using the beveled washers (4) and flat head screws (3) from the kit.

### NOTE

- The beveled washers install with the angled face against the cover.
  - **DO NOT** apply liquid threadlocker to the screws.
8. Allow the washers to rotate into alignment with the underside of the lid. Tighten the screws to 1.4–1.7 N·m (12–15 in-lbs).
  9. Repeat Steps 1-8 for the second saddlebag lid.

## Wire Routing

1. See Figure 2. Lay strips of masking tape on the outside of the inboard saddlebag wall, in the approximate area of the required wiring hole. Carefully measure and mark the hole location as shown.

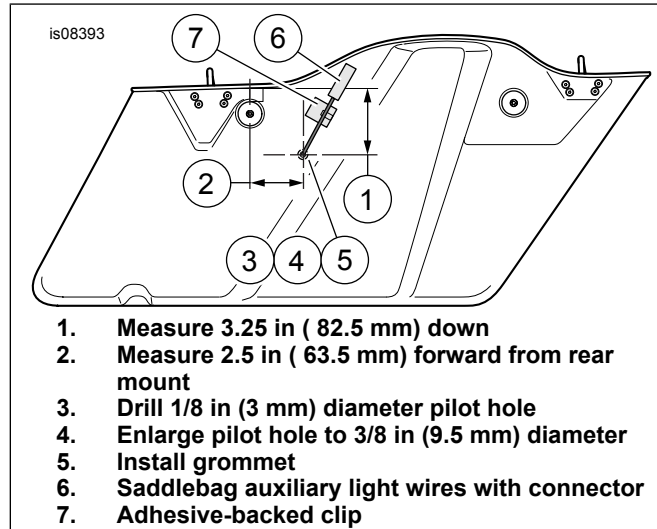
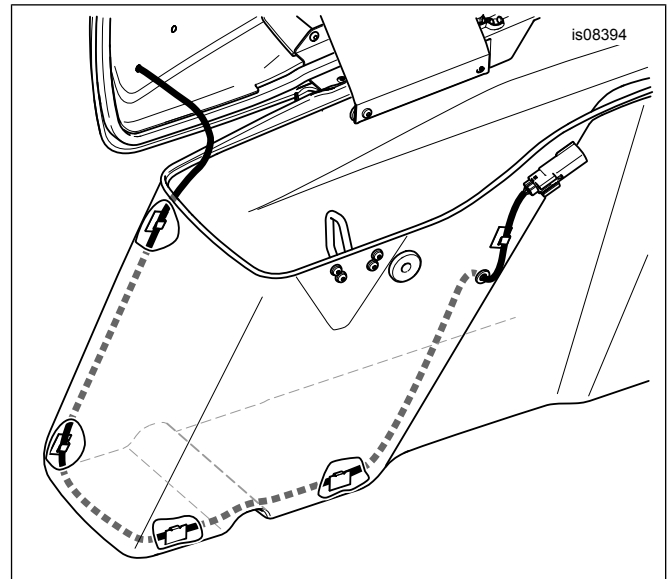

**Figure 2. Drill Wiring Hole in Inboard Saddlebag Wall (Left Bag Shown)**

2. Drill a 3 mm (1/8 in) diameter pilot hole at the marked location. Enlarge the hole to 9.5 mm (3/8 in) diameter. Remove the masking tape. Lightly sand the hole to remove burrs and sharp edges. Clean the saddlebag with a 50-50 mixture of isopropyl alcohol and distilled water. Allow to dry completely.
3. Install a grommet (7) from the kit into the newly drilled wiring hole.
4. See the service manual. Install saddlebag latch to cover. Install cover with latch assembly to saddlebag.
5. Get four adhesive-backed wire clips (8) from the kit. See Figure 3. Use the clips to route the spoiler wiring:
  - a. Down the saddlebag outboard rear wall,
  - b. across the bottom to the inside wall,
  - c. forward to the shock absorber clearance bulge,
  - d. up to the grommet.

### NOTE

- Apply a light coat of liquid soap to the wiring and grommet as necessary to ease installation.
  - Make sure that there is sufficient slack in the wiring to open and close the saddlebag lid easily.
6. Insert the spoiler wiring through the grommet.



**Figure 3. Spoiler Light Wire Routing Inside Saddlebag (Left Side Shown)**

7. Get a four-way Molex pin housing (9) from the kit. See the service manual appendix. Insert the spoiler wires into the pin housing:

- **Red/Yellow** wire to **cavity 1**.
- **Blue/Red** wire to **cavity 2**.
- **Black** wire to **cavity 3**.
- **Blue** wire to **cavity 4**.

8. Get an adhesive-backed wire clip (8) from the kit. Use the clip to fasten the spoiler wiring to the outside of the saddlebag as shown. See Figure 2.
9. Repeat Steps 1-8 for the second saddlebag.
10. See the service manual. Install saddlebags.
11. Get the wire harness (10) from the kit. Unplug the six-way vehicle harness connector [C7] under the seat:
  - **FLHX, FLHXS, FLHXSE, FLTRX, FLTRXS** models: Next to the Electronic Control Module (ECM).
  - **ALL other models:** Top front of rear fender.
12. Plug the six-way spoiler harness connectors into connector halves [C7A] and [C7B].
13. Route the left leg of the harness down the left frame tube. Route the right leg of the harness down the right frame tube.
14. Plug the spoiler connectors into the harness connectors.
15. Secure wiring to the frame tubes with cable straps (11) as needed.
16. See the service manual. Install side covers.

## COMPLETION

### NOTE

Verify that the ignition is **OFF** before installing the main fuse.

1. See the service manual. Install the main fuse.

### ▲ WARNING

**Be sure that all lights and switches operate properly before operating motorcycle. Low visibility of rider can result in death or serious injury. (00316a)**

2. Check for proper function of rear lighting. With ignition **OFF**: Tail lamps and spoiler lamps are off. Turn ignition switch to **ACCY** position: Turn ignition switch **ON**, but do not start the motorcycle. Apply brake **WITH** hazard warning (emergency four-way flasher) actuated:
  - a. Actuate brake or turn signal. Rear lamps remain off.
  - b. Actuate hazard warning (emergency four-way flasher). **NO** lamps flash.
  - c. Spoiler lamps and tail lamps are illuminated.
  - d. Actuate front brake lever or rear brake pedal. Spoiler lamps and tail lamps noticeably brighten.
  - e. Actuate left and right turn signal. Turn signal lamp and spoiler lamp **DO NOT** flash.
  - f. Actuate hazard warning (emergency four-way flasher). Both turn signal lamps and spoiler lamps flash.
  - g. Turn ignition **OFF**. Both turn signal lamps continue to flash. Spoiler lamps turn off.
  - h. Turn ignition switch to **ON** or **ACCY** position. Turn **OFF** hazard warning flasher. Turn signal lamps stop flashing.
  - i. Tail lamps and spoiler lamps are illuminated.
  - j. Actuate front brake lever or rear brake pedal. Spoiler lamps and tail lamps noticeably brighten.

- k. Actuate turn signal. The correct turn signal lamp and spoiler lamp both flash.
- l. Actuate hazard warning (emergency four-way flasher). Both turn signal lamps and spoiler lamps flash.
- m. **FLHR, FLHTKSE, FLHXSE, FLTRUSE, Canadian FLHX/S and FLTRX/S models:** Both turn signal lamps flash on and off. Both spoiler lamps flash from high to low intensity. **FLHTCU, FLHTK, Domestic FLHX/S and FLTRX/S models:** Tail lamps and spoiler lamps noticeably brighten, but do not flash.
- n. **ALL models:** Turn ignition **OFF**. Both turn signal lamps continue to flash. Both spoiler lamps turn off.
- o. Turn ignition switch to **ON** or **ACCY** position. Turn **OFF** hazard warning flasher. Turn signal lamps stop flashing.

### ▲ WARNING

**After installing seat, pull upward on seat to be sure it is locked in position. While riding, a loose seat can shift causing loss of control, which could result in death or serious injury. (00070b)**

3. See the service manual. Install seat.

## IN USE

### Care and Cleaning

- The spoilers are constructed of polycarbonate. **DO NOT** use benzene, paint thinner, gasoline or any other type of harsh cleaner.

# SERVICE PARTS

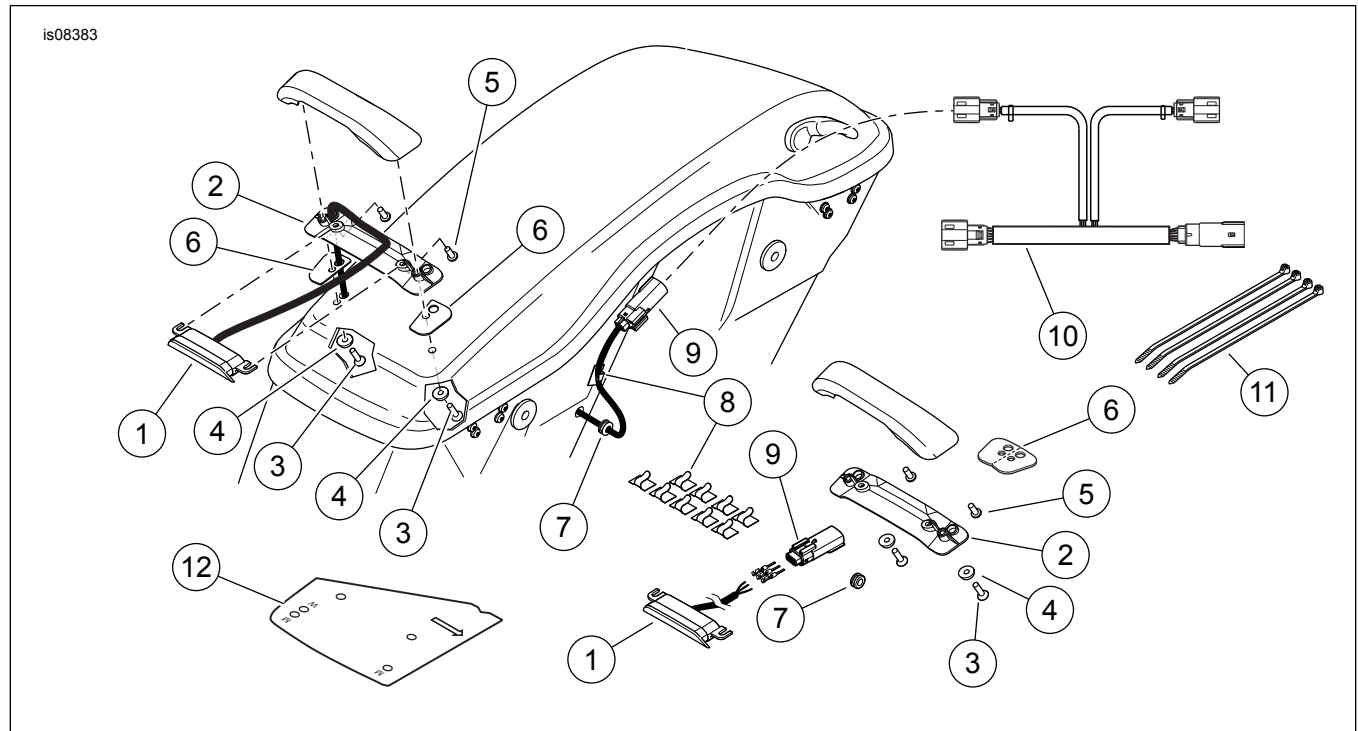

Figure 4. Service Parts, Saddlebag Spoiler and Auxiliary Rear Light Kit

Table 1. Service Parts

Kit	Item	Description (Quantity)	Part Number
Kit 90200735 (Red Lens)	1	Auxiliary light assembly, with red lens (2)	68000058
Kit 90200736 (Smoke Lens)	1	Auxiliary light assembly, with smoke lens (2)	68000060
Parts common to BOTH kits	2	Base, saddlebag spoiler (2)	Not sold separately
	3	Flat head socket cap screw, #10-24 x 19 mm (0.75 in) long (4)	Not sold separately
	4	Washer, nylon, special beveled (4)	Not sold separately
	5	Button head socket cap screw, #8-32 x 12.7 mm (0.50 in) long (4)	Not sold separately
	6	Gasket (set of 2), closed cell neoprene (2)	Not sold separately
	7	Grommet (2)	11410
	8	Clip, metal, adhesive back, 6.4 mm (0.25 in) (10)	10102
	9	Pin housing, four-way Molex, black (2)	72175-07BK
	10	Wire harness, spoiler auxiliary lighting	69200552
	11	Cable strap (4)	10006
	12	Template	Not sold separately
<b>Item mentioned in text, but not included in this kit:</b>			
	A	Spoiler cover (set of 2)	