



# INSTRUCTIONS

J05709

2014-02-06



## TOURING LED ELECTRA-GLO SADDLEBAG LIGHT KIT

### GENERAL

#### Kit Numbers

68000082, 68000083

#### Models

For model fitment information, see the P&A retail catalog or the Parts and Accessories section of [www.harley-davidson.com](http://www.harley-davidson.com) (English only).

#### Installation Requirements

**2014-2016 Touring Models:** Separate purchase of harness extension (Part No. 69200722) is required to locate the accessory circuit connector.

**2017 and Later Touring Models:** Separate purchase of harness extension (Part No. 69201599) is required to locate the accessory circuit connector.

#### Service Manual Required

##### ▲ WARNING

**Rider and passenger safety depend upon the correct installation of this kit. Use the appropriate service manual procedures. If the procedure is not within your capabilities or you do not have the correct tools, have a Harley-Davidson dealer perform the installation. Improper installation of this kit could result in death or serious injury. (00333b)**

##### NOTE

*This instruction sheet references service manual information. A service manual for this year/model motorcycle is required for this installation. One is available from a Harley-Davidson dealer.*

#### Electrical Overload

##### NOTICE

**It is possible to overload the vehicle's charging system by adding too many electrical accessories. If the combined electrical accessories operating at any one time consume more electrical current than the vehicle's charging system can produce, the electrical consumption can discharge the battery and cause damage to the vehicle's electrical system. (00211d)**

##### ▲ WARNING

**When installing any electrical accessory, be certain not to exceed the maximum amperage rating of the fuse or circuit breaker protecting the affected circuit being modified. Exceeding the maximum amperage can lead to electrical failures, which could result in death or serious injury. (00310a)**

This Touring LED Electra Glo Saddlebag Light Kit requires up to **720 mA** additional current from the electrical system.

#### Kit Contents

See Figure 4 and Table 1

### INSTALLATION

1. Remove the right saddlebag from the vehicle. See the service manual.
2. Remove the saddlebag lid. See the service manual.
3. Position the saddlebag upside down on a protected surface with the latch loops overhanging the edge.
4. With the adhesive backing still in place, test fit the right E-Glo light rail:
  - a. Align the semicircular shape of the rail with the corresponding shape at the front of the saddlebag.
  - b. Verify that the rail flange makes contact all along the saddlebag base and consistently follows the saddlebag along the entire length of the long leg.
  - c. With the help of an assistant, hold the rail in place and trace reference marks on the saddlebag with a contrasting colored grease pencil.
5. Lift the light rail from its test fit location.
6. Clean the saddlebag in the areas corresponding to the tape installed on the E-Glo Rails with a mixture of equal parts of isopropyl alcohol and distilled water. Allow to dry completely.
7. See Figure 1. Prepare the following pieces of masking tape. Cut (2) 30.5 cm (12 in) and 76 mm (3 in) strips of masking tape. Apply the 76 mm (3 in) strips to the center of the 30.5 cm (12 in) strips, adhesive to adhesive, creating a tack free zone.



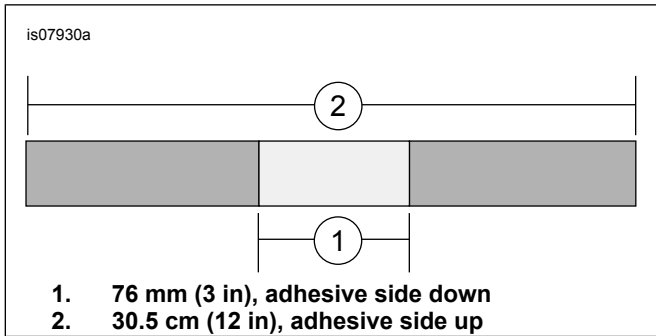

**Figure 1. Create tack free zone**

8. Remove the adhesive tape backing from the short leg and from the semicircular shape of the rail. (Do not remove the backing from long leg at this time.)
9. Position the light rail as in the test fit above. Flex the short leg away from the saddlebag while lowering the assembly down into position.
10. Once seated and with the help of an assistant, hold the front of the E-Glo rail firmly in position while flexing the long leg away from the saddlebag at the rear. Remove the adhesive backing from the rail. Verify alignment with the reference marks and allow the long leg to fully contact the saddlebag.
11. Apply firm sliding pressure in all tape areas. (Do not use extreme pressure over the lens.)
12. Temporarily clamp the rail in place using the masking tape as follows:
  - a. Position the tape strips at a right angle to the long leg of the E-Glo rails with the 3 inch (76 mm) tack free zone stretched across the face of the light rail.
  - b. Pull the tape tight while adhering the ends to the saddlebag.
13. See Figure 2. Route the E-Glo Light Rail wiring as shown. Retain the wiring with the clips provided in the kit.

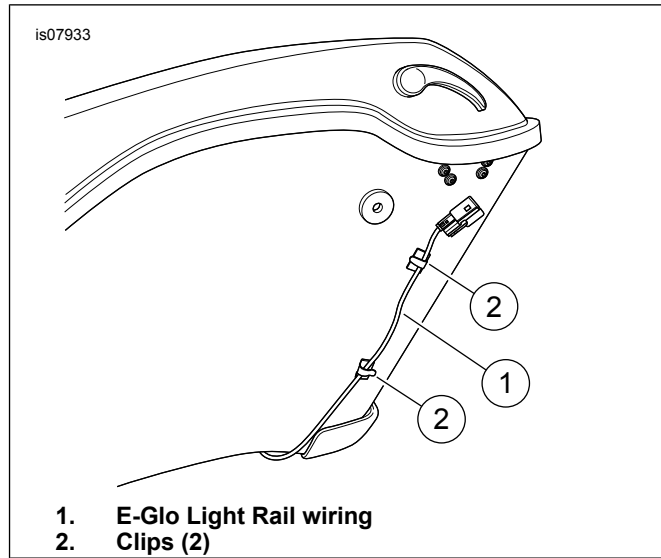

**Figure 2. Wire Routing**

14. Repeat 1-13 for the left saddlebag.
15. Allow the assemblies to dwell for 24 hours.
16. Remove the reference marks.
17. See the service manual. Install the saddlebag lids.
18. See the service manual. Install the saddlebag to the vehicle.

## PREPARATION

### ⚠ WARNING

**To prevent accidental vehicle start-up, which could cause death or serious injury, remove main fuse before proceeding. (00251b)**

### NOTE

- **For vehicles equipped with security siren:** With security fob present, turn ignition switch ON. After system is disarmed, turn ignition switch OFF. **IMMEDIATELY** remove the main fuse per the service manual.
- **For vehicles WITHOUT security siren:** See the service manual to remove the main fuse.

## HARNESS ROUTING

1. Remove the main fuse. See the service manual.
2. Remove the seat. See the service manual.
3. See Figure 3. Install the electrical Harness Extension per the instructions in that kit (see installation requirements).

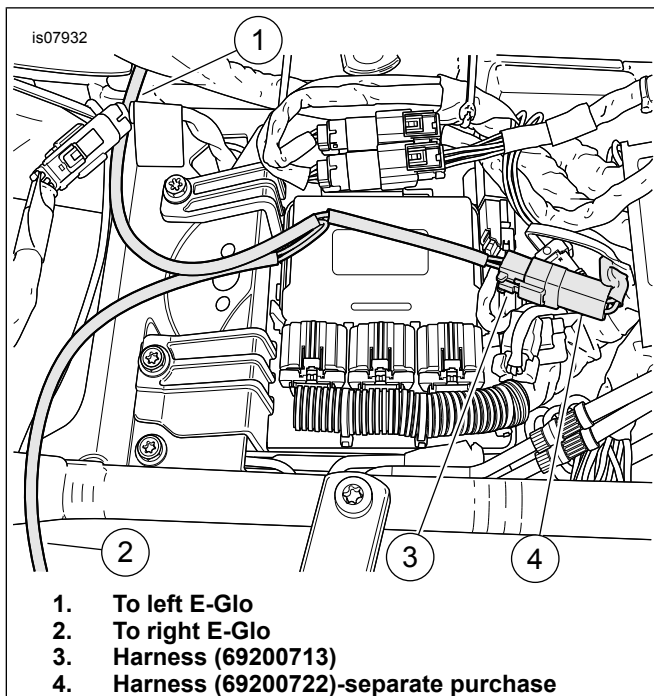

**Figure 3. Install Electrical Connection Harness**

4. Get harness 69200713 from the kit. Plug the harness into connector of:
  - a. **2014-2016 Touring Models:** 69200722. (If the connector on 69200722 is consumed by other accessories purchase adapter harness 70264-94.)
  - b. **2017 and Later Touring Models:** 69201599. (If the connector on 69201599 is consumed by other accessories purchase adapter harness 69201706.)

5. Route one leg of the harness toward the right saddlebag and route the other leg toward the left saddlebag.
6. Open the right saddlebag and release the saddlebag from the vehicle by removing the 1/4 turn fasteners. Rock the saddlebag outward to gain access to the E-Glo Light Rail connector on the bag.
7. Plug the harness connector into the connector on the saddlebag.
8. Return the saddlebag to its normal position using the 1/4 turn fasteners removed above.
9. Repeat for the opposite side.
10. Secure the harness to existing wiring or frame members using the cable ties provided in the kit.

## COMPLETION

1. See service manual. Replace main fuse.
  - a. With the ignition in the OFF position; Light Rail LEDs are OFF.
  - b. With the ignition in the ON position; Light Rail LEDs are ON.
  - c. With the ignition in the ACC position; Light Rail LEDs are OFF.
2. See service manual. Install seat. After installing seat, pull up on the seat to verify that it is secure.

## SERVICE PARTS

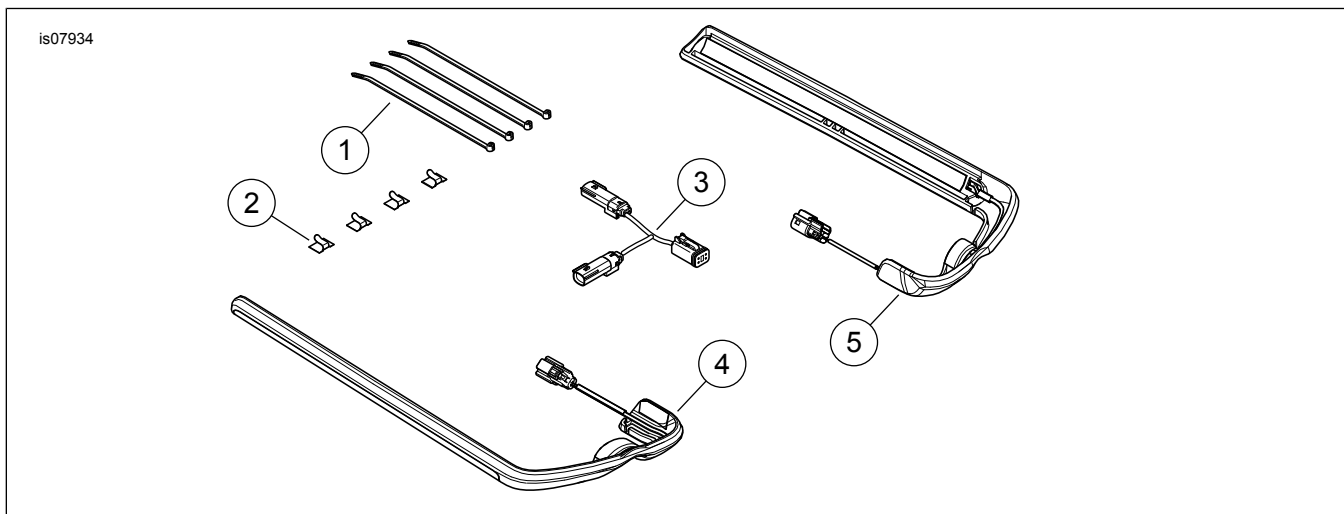

**Figure 4. Service Parts: Electra-Glo Saddlebag Light Kit**

**Table 1. Service Parts Table**

Item	Description (Quantity)	Part Number
1	Cable strap (4)	10006
2	Clip (4)	10102
3	Wiring harness, saddlebag E-Glo light	Not Sold Separately

**Table 1. Service Parts Table**

<b>Item</b>	<b>Description (Quantity)</b>	<b>Part Number</b>
4	Electra-Glo light rail, right	Not Sold Separately
5	Electra-Glo light rail, left	Not Sold Separately