



INSTRUCTIONS

J05633

2012-10-26



TOURING CHROME LOWER FORK SLIDER KIT

GENERAL

Kit Number

45500167

Models

For model fitment information, see the P&A retail catalog or the Parts and Accessories section of www.harley-davidson.com (English only).

This kit is a direct replacement for the original equipment (OE) fork sliders, and installs in the same manner.

Installation Requirements

Proper installation of this kit requires the following parts and supplies:

- Two fork tube plug O-rings (Part No. 45845-77)
- Two 6 mm damper tube screws with copper washers (Part No. 45405-75A)
- Loctite[®] 243 Medium Strength Threadlocker and Sealant - Blue (Part No. 99642-97)
- Either Permatex[®] Anti-Seize Lubricant (Part No. 98960-97) or Loctite SILVER GRADE Anti-Seize lubricant (Part No. 11100001).
- Type "E" Hydraulic Fork Oil (Part No. 99884-80)

Proper installation of this kit also requires the following special tools:

- FORK HOLDING TOOL (Part No. HD-41177)
- FORK SEAL/BUSHING DRIVER (Part No. HD-34634)
- FRONT FORK OIL LEVEL GAUGE (Part No. HD-59000B)

⚠ WARNING

Rider and passenger safety depend upon the correct installation of this kit. Use the appropriate service manual procedures. If the procedure is not within your capabilities or you do not have the correct tools, have a Harley-Davidson dealer perform the installation. Improper installation of this kit could result in death or serious injury. (00333b)

NOTE

This instruction sheet refers to service manual information. A service manual for this year/model motorcycle is required for this installation and is available from a Harley-Davidson dealer.

Kit Contents

See Figure 2 and Table 1.

PREPARATION

NOTE

For vehicles equipped with security siren:

- **2007 and later:** Verify that the Hands-Free Fob is present. Turn the ignition key switch to IGNITION.
- **2006 and earlier:** Disarm the siren with the key fob.

For Vehicles With Main Fuse:

⚠ WARNING

To prevent accidental vehicle start-up, which could cause death or serious injury, remove main fuse before proceeding. (00251b)

1. See the service manual and remove the main fuse.

For Vehicles With Main Circuit Breaker:

⚠ WARNING

To prevent accidental vehicle start-up, which could cause death or serious injury, disconnect negative (-) battery cable before proceeding. (00048a)

1. See the service manual to remove the seat and disconnect the negative (black) battery cable from the negative (-) battery terminal. Retain all seat mounting hardware.
2. **For ALL models:** Turn the ignition key switch OFF if not already done.

REMOVAL

⚠ WARNING

Wear safety glasses or goggles when servicing fork assembly. Do not remove slider tube caps without relieving spring preload or caps and springs can fly out, which could result in death or serious injury. (00297a)

1. Support the motorcycle so the front end is off the floor and the forks are fully extended.
2. See the service manual to remove the front fender, front brake calipers and front wheel.

NOTE

On some models additional parts must also be removed to access the front forks. See the service manual.

3. **On models equipped with air-adjustable front suspension,** bleed the system per service manual instructions.
4. Remove, drain and disassemble the front forks per the service manual.



5. See the service manual to clean and inspect all parts not being replaced for wear or damage. Replace items as necessary.
6. **For models with fork-mounted reflectors:** Using a piece of dental floss (or similar material) in a back and forth motion, loosen the top and bottom of the reflector from the fork slider. Rotate the reflector from side to side until it can be removed. Save the reflector for later assembly. Repeat for the remaining reflector. Peel off any excess adhesive from both reflectors.

INSTALLATION

The fork sliders included in this kit install in the same manner as the original equipment parts. See the service manual for proper installation procedures.

Pay close attention to all warnings, cautions, and torque specifications when installing these fork sliders.

NOTE

Prior to installation of this kit, check the bores of the new chrome sliders to be certain they are free of dirt and debris, or damage to the new sliders may occur.

1. Assemble the front fork tubes per service manual instructions, with the following exceptions:
 - a. Replace the original fork sliders with the chrome sliders (see Figure 2, items 1 and 2) from the kit.
 - b. Replace the original slider oil seal on each side with a **new** slider oil seal (5) from the kit.
 - c. Replace any other worn seals, bushings or other items as needed.
 - d. Install a **new** 6 mm damper tube screw with copper washer (Part No. 45405-75A, purchased separately) at the bottom of each fork slider.

NOTE

Do not use an impact wrench to tighten the drain screws. Use of an impact wrench may damage the screws.

2. Install the **new** chrome drain screws and washers (4) from the kit. Tighten to 5.8–8.8 N·m (52–78 **in-lbs**).
3. Fill the front forks with Type "E" Hydraulic Fork Oil (Part No. 99884-80) following service manual instructions.
4. Install two **new** O-rings (Part No. 45845-77, purchased separately) under the fork tube plugs.
5. Complete the assembly of the front fork tubes per service manual instructions. Replace the oil seal under the fork top bolt with a **new** packing oil seal (6) from the kit.
6. Install the front forks to the motorcycle per the service manual. Install the front wheel, front brake calipers, front fender and any additional items removed earlier.
7. **On models equipped with air-adjustable front suspension**, refill the air-adjustable suspension system after assembly per service manual instructions.

▲ WARNING

Federal Motor Vehicle Safety Standard (FMVSS) 108 requires motorcycles to be equipped with rear and side reflectors. Be sure rear and side reflectors are properly mounted. Poor visibility of rider to other motorists can result in death or serious injury. (00336b)

8. **For models with fork-mounted reflectors:**
 - Ambient temperature should be **at least** 16 °C (60 °F) for proper adhesion of the reflectors to the fork sliders.
 - Allow **AT LEAST** 24 hours after applying the reflectors before exposing the area to vigorous washing, strong water spray or extreme weather.
 - The adhesive bond will increase to maximum strength after about 72 hours at normal room temperature.
9. Peel the liner from **one side** of the foam double-sided tape (see Figure 2, item 7). Position the tape to the back of the reflector, and press firmly into place. Repeat for the remaining reflector.
10. Clean the reflector mounting area of the fork slider with a 50-50 mixture of isopropyl alcohol and distilled water. Allow to dry thoroughly.

NOTE

The reflectors are side-specific. The reflectors install so that the top and bottom edges are parallel to the ground, as shown in Figure 1.

11. Peel the remaining liner from the tape. Place the reflector in position on the fork slider. Locate the bottom edge of the reflector 50 mm (2.0 in) above the center of the axle shaft as shown, and press firmly into place. Hold the reflector in position with steady pressure for approximately one minute. Repeat for the remaining reflector.

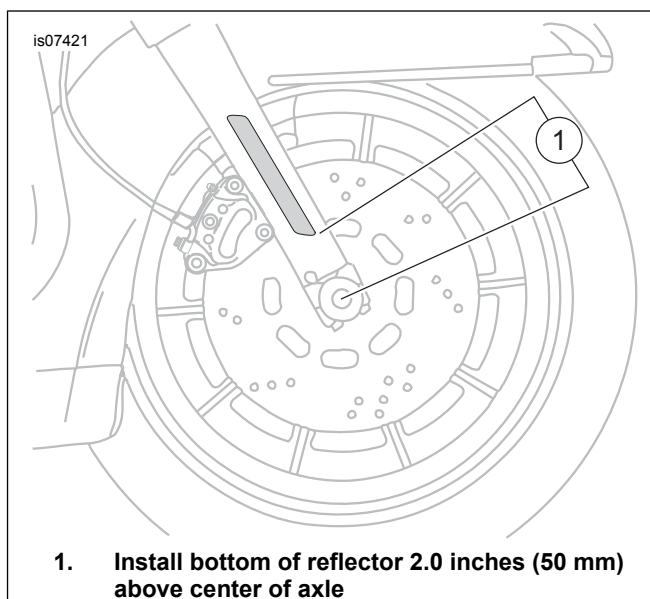

Figure 1. Reflector Placement

COMPLETION

NOTE

*Verify that the ignition key switch is in the OFF position **before** installing the main fuse or attaching the negative battery cable.*

1. **Models with main fuse:** See the service manual and install the main fuse. **Models with main circuit breaker:** See the service manual and attach the negative battery cable. Apply a light coat of Harley-Davidson electrical contact lubricant (Part No. 99861-02), petroleum jelly or corrosion retardant material to the negative battery terminal.

▲ WARNING

After installing seat, pull upward on seat to be sure it is locked in position. While riding, a loose seat can shift causing loss of control, which could result in death or serious injury. (00070b)

2. **For ALL models:** See the service manual and install the seat.

▲ WARNING

Whenever a wheel is installed and before moving the motorcycle, pump brakes to build brake system pressure. Insufficient pressure can adversely affect brake performance, which could result in death or serious injury. (00284a)

▲ WARNING

After repairing the brake system, test brakes at low speed. If brakes are not operating properly, testing at high speeds can cause loss of control, which could result in death or serious injury. (00289a)

3. Pump the brakes prior to test riding the motorcycle.
4. Test ride the vehicle to verify proper fork travel and rebound.

SERVICE PARTS

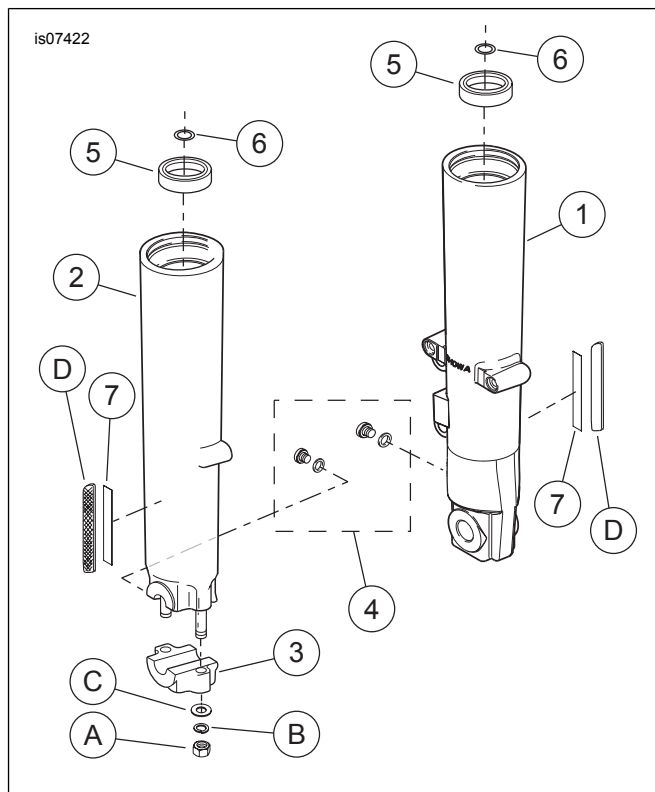

Figure 2. Service Parts, Chrome Lower Fork Slider Kit

Table 1. Service Parts

Item	Description (Quantity)	Part Number
1	Fork slider, chrome (left)	45500169
2	Fork slider, chrome (right)	45500168
3	Axle holder, chrome (right)	45500170
4	Drain screw kit, chrome (includes 2 screws, 2 washers)	45848-03
5	Oil seal (2)	45875-84A
6	Packing oil seal (2)	45733-48
7	Foam tape, double-sided (2)	53791-06
Items mentioned in text, but not included in kit.		
A	Nut (2)	
B	Lockwasher (2)	
C	Flat washer (2)	
D	OE reflector (2)	