



INSTRUCTIONS

J05715

2013-05-22



TOUR-PAK LATCH AND HINGE KIT

GENERAL

Kit Number

53000343

Models

For model fitment information, see the P&A Retail Catalog or the Parts and Accessories section of www.harley-davidson.com (English only).

PREPARATION

NOTE

Support the Tour-Pak® lid to keep it from opening beyond the normal travel.

1. Open the Tour-Pak. Support lid partly open.
2. See Figure 1. Remove screws (2) securing tether anchor (1).
3. Remove Tour-Pak liner.
4. Loosely install tether anchor.
5. Fully open the Tour-Pak lid.

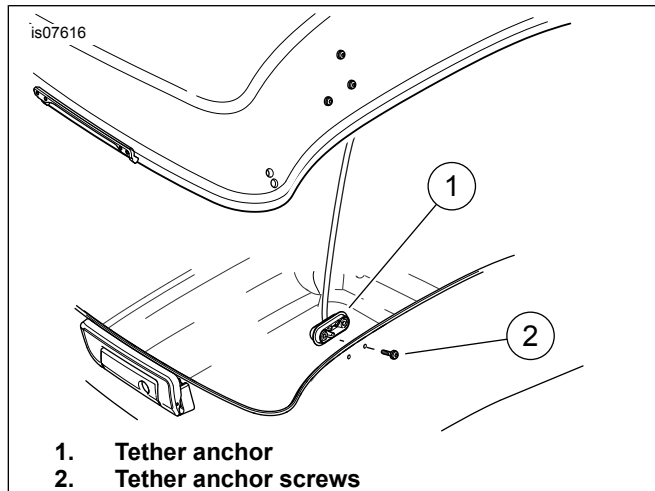

Figure 1. Tether Anchor Screws

LATCH HANDLE

REMOVAL

1. See Figure 2. Open latch handle (1) completely.
2. Remove two screws (2). Retain for assembly.
3. Remove Tour-Pak lock.

NOTE

Tour-Pak lock contains no service parts. Do not disassemble.

4. Remove screws (3).
5. Remove latch handle assembly.
6. Discard latch handle and screws (3).

INSTALLATION

1. See Figure 2. Install latch handle with **new** screws (3). Tighten to 2.8–3.9 N·m (25–35 **in-lbs**).
2. Orient Tour-Pak lock with key notches toward the top. Secure with original screws (2).
3. Tighten to 2.8–3.9 N·m (25–35 **in-lbs**).

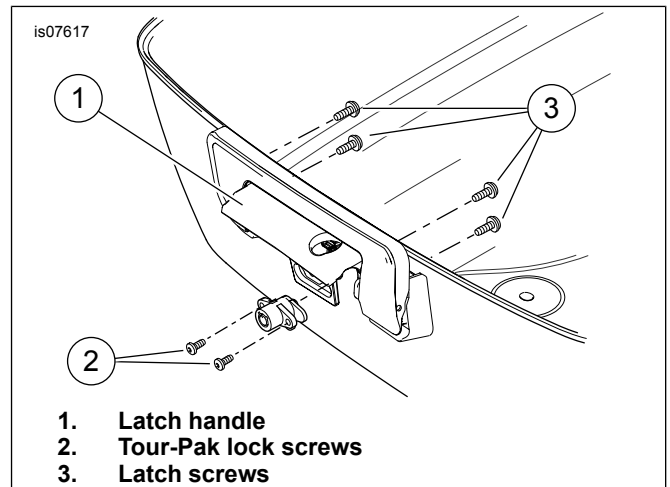

Figure 2. Latch Handle and Lockset Assembly

HINGES

REPLACEMENT

NOTE

- Replace one hinge at a time.
- Hinges can be identified with an F(ront) or R(ear) molded into the mounting side of each casting.
- Take care to not damage seal when removing screws from Tour-Pak.

1. See Figure 3. Remove eight screws (1, 2) securing hinge to Tour-Pak and lid.
2. Remove hinge.
3. Discard hinges and screws.

NOTE

The screws (2) nearest the edge of the lid are washerless and shorter than the remaining six for each hinge. Install the shorter screws first.

4. Hold hinge in place. Install screws securing hinge to Tour-Pak and lid. Tighten to 2.8–3.9 N·m (25–35 **in-lbs**).
5. Repeat with remaining hinge.

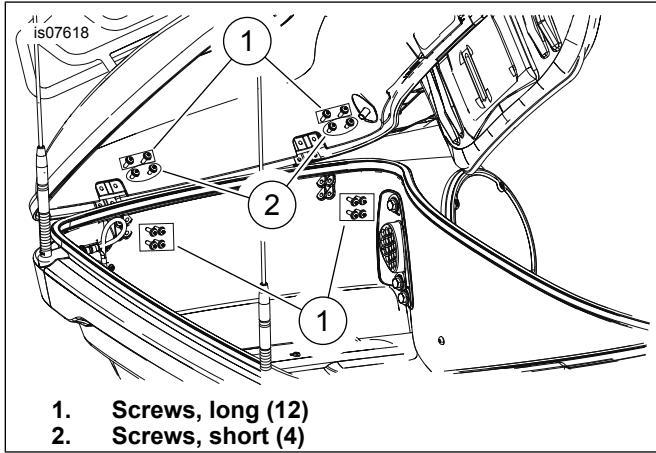

Figure 3. Replace Hinges

COMPLETION

NOTE

Support the Tour-Pak lid to keep it from opening beyond the normal travel.

1. Support lid partly open.
2. See Figure 1. Remove screws securing tether anchor.
3. Install Tour-Pak liner.
4. Install tether anchor with two screws (2). Tighten to 2.8–3.9 N·m (25–35 **in-lbs**).
5. Close the Tour-Pak lid.

SERVICE PARTS

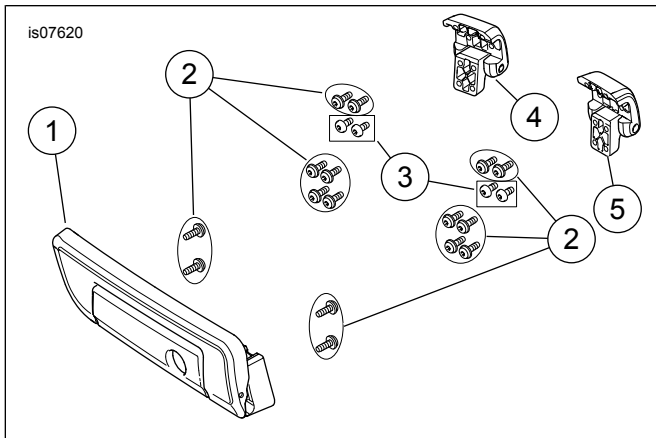

Figure 4. Service Parts: Latch Handle and Hinge Kit

Table 1. Service Parts Table

Item	Description (Quantity)	Part Number
1	Latch handle assembly	53000342
2	Screw with washer (16)	10200061
3	Screw, short (4)	10200062
4	Hinge, front	53000345
5	Hinge, rear	53000344