



INSTRUCTIONS

J05637

2012-06-20



BURST COLLECTION SADDLEBAG LATCH FACEPLATE KIT

GENERAL

Kit Number

90200821

Models

For model fitment information, see the P&A Retail Catalog or the Parts and Accessories section of www.harley-davidson.com (English only).

Additional Parts Required

This kit requires the use of Loctite® 243 Threadlocker and Sealant - Blue (99642-97). Loctite is available from a Harley-Davidson dealer.

⚠ WARNING

Rider and passenger safety depend upon the correct installation of this kit. Use the appropriate service manual procedures. If the procedure is not within your capabilities or you do not have the correct tools, have a Harley-Davidson dealer perform the installation. Improper installation of this kit could result in death or serious injury. (00333b)

NOTE

This instruction sheet references service manual information. A service manual for your model motorcycle is required for this installation and is available from a Harley-Davidson dealer.

Kit Contents

See Figure 5 and Table 1.

⚠ WARNING

Federal Motor Vehicle Safety Standard (FMVSS) 108 requires motorcycles to be equipped with rear and side reflectors. Be sure rear and side reflectors are properly mounted. Poor visibility of rider to other motorists can result in death or serious injury. (00336b)

INSTALLATION

Remove Saddlebag

NOTE

Read all instructions first before installing kit.

1. Lay a clean pad or blanket on the work surface to protect the saddlebag's painted surfaces.
2. See Figure 1. Open the saddlebag lid.
3. See service manual and remove the saddlebag (1) from the motorcycle, leaving the lid open.

4. Lay the saddlebag flat on the pad or blanket with the inboard side facing up and the lid closest to you.

Remove Original Equipment Faceplate

1. See Figure 1. Remove two TORX® screws (2) holding the check strap (3) and latch assembly (4) to the saddlebag (1). Save screws for later use.

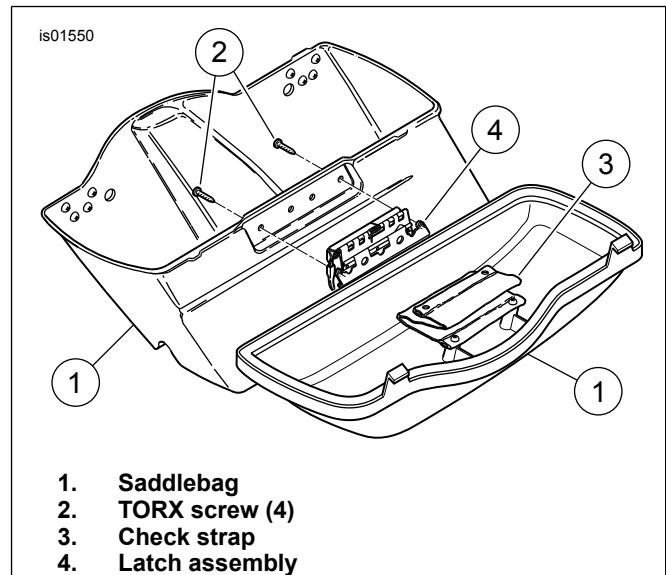

Figure 1. Saddlebag Lid Removal (left side shown)

2. Remove the remaining two TORX screws (2) holding the latch assembly to the saddlebag. Set the saddlebag aside.

NOTE

These instructions assume that the latch is not removed from the saddlebag lid. If there is any doubt whether the procedure can be done without scratching the painted surfaces of the lid, remove the remaining TORX screws to completely remove the latch assembly.

3. See Figure 2. Remove two TORX screws (1) and the lock assembly (2) from faceplate. Save parts for installation.
4. Remove and discard the hex nut (3) holding the stud at the opposite end of the faceplate.
5. Rotate the latch assembly (4) so the faceplate is facing up.
6. Remove and discard two TORX screws (5) and original equipment faceplate with reflector (6) from lock assembly and latch assembly.



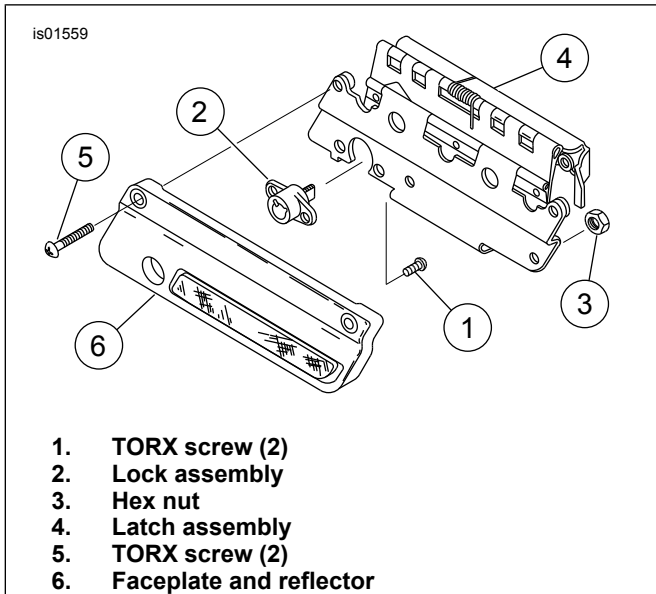

Figure 2. Remove Original Equipment Faceplate

Install Faceplate

NOTE

The new faceplates are side-specific and must be installed on the correct side.

1. See Figure 3. Align the two mounting holes and the lock hole on the faceplate with the corresponding holes in the latch assembly.

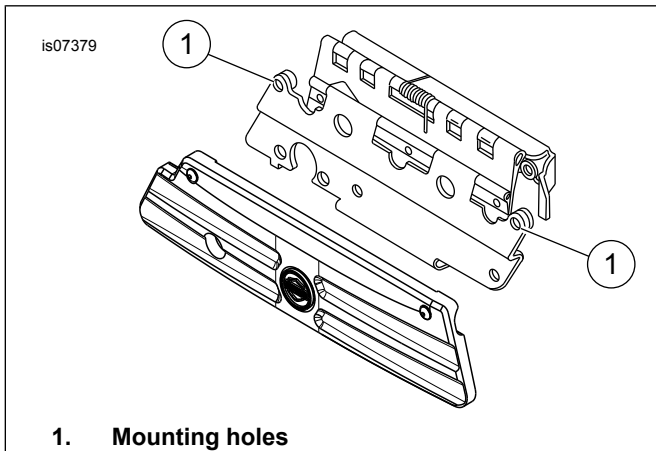

Figure 3. Align Mounting Holes

2. See Figure 5. Apply Loctite 243 (blue) to threads of two screws (1) from kit.
3. Loosely install faceplate (3) on latch assembly (A) with two screws (1).
4. Rotate the latch assembly (A) so the faceplate is facing down.
5. Apply Loctite 243 (blue) to threads of two TORX screws (B) previously removed from lock assembly (C).
6. Loosely install lock assembly (C) on latch assembly (A) using two TORX screws (B).

7. Apply Loctite 243 (blue) to threads of screw (1) and install on opposite side of faceplate.
8. Tighten TORX screws (B) that attach lock assembly (C) securely.
9. Tighten screws (1) that attach faceplate to latch assembly (A) securely.
10. Install latch assembly (A) to saddlebag (F) with previously removed TORX screws (E). Tighten TORX screws securely.
11. Install check strap (D) and latch assembly (A) to saddlebag (F) with previously removed TORX screws (E). Tighten TORX screws securely.
12. Repeat faceplate removal and installation for opposite side saddlebag.

Install Reflector

1. See Figure 4. Using a 50/50 isopropyl alcohol/water solution, thoroughly clean the reflector mounting location. Allow it to dry completely.

NOTE

Test the fit prior to removing the adhesive backing from the reflector.

2. Remove adhesive liner from reflector (1).
3. Install the reflector down 8.3 cm (3.25 in) (3) from the closed lid of the saddlebag and 5.7 cm (2.25 in) (2) in from the end of the saddlebag.
4. Repeat reflector installation for opposite side saddlebag.
5. Allow the adhesive to cure for 24 hours at no less than 16 °C (60 °F).

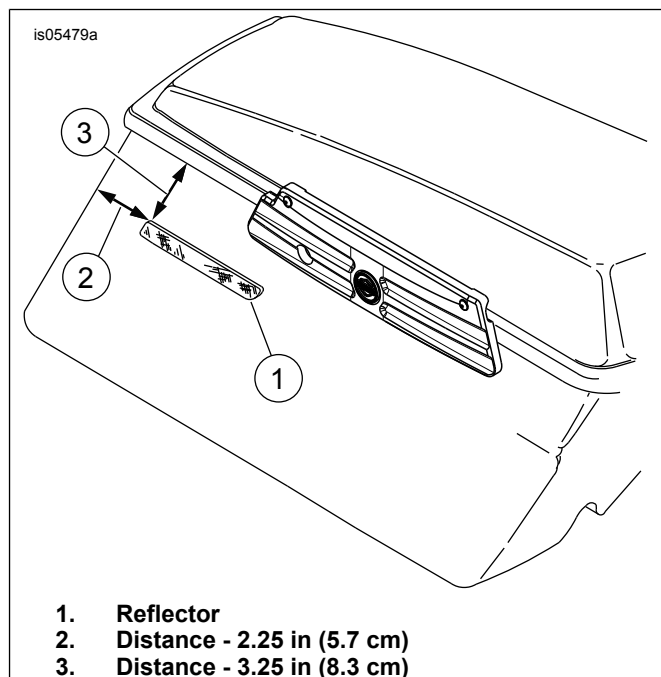

Figure 4. Reflector Location

Install Saddlebag

1. See Figure 1. Close the saddlebag lid.

2. See the service manual and install saddlebag (1).

3. Repeat procedures for opposite saddlebag faceplate.

SERVICE PARTS

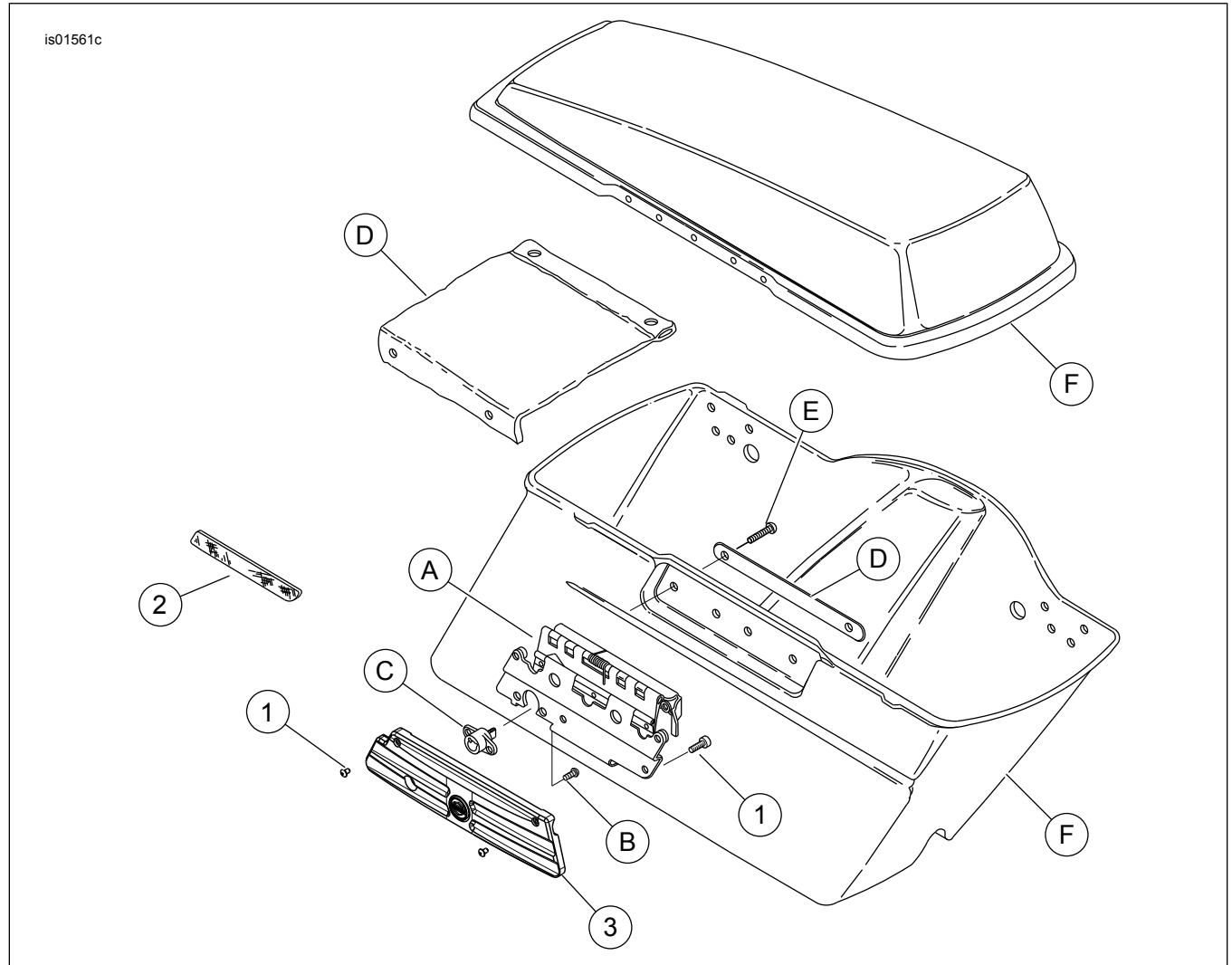

Figure 5. Service Parts: Saddlebag Latch Faceplate Kit

Table 1. Service Parts: Saddlebag Latch Faceplate Kit

Item	Description (Quantity)	Part Number
1	Button head cap screw (6)	10200212
2	Reflector, red, right	59287-92
	Reflector, red, left (not shown)	59288-92
3	Faceplate, right	90200849
	Faceplate, left (not shown)	90200848
Items mentioned in text, but not included in kit:		
A	Latch assembly	
B	TORX screw (2)	
C	Lock assembly	
D	Check strap	
E	TORX screw (4)	
F	Saddlebag	