



INSTRUCTIONS

J05721

2013-05-16



CHROME WIND DEFLECTOR

GENERAL

Kit Number

57400146A

Models

For model fitment information, see the P&A Retail Catalog or the Parts and Accessories section of www.harley-davidson.com (English only).

Kit Contents

See Figure 3 and Table 1.

There are no Service Parts available with this kit.

INSTALLATION FOR FLHR, 95-13 FLHT, FLHTC

1. See Figure 1. On right side of vehicle, locate two mounting acorn nuts which secure the nacelle and the passing lamp bracket to the fork assembly.
2. Remove the upper and lower acorn nut and flat washer, being careful to note position of all spacers and hardware.

NOTE

For proper fitment, passing lamp/turn signals may have to be moved to forward portion of mounting slot.

3. Place the wind deflector over the nacelle mounting studs outside of passing lamp support bracket.
4. Install the acorn nut and flat washer removed earlier.
5. Adjust wind deflector as far forward as possible to allow for clearance with engine guard. Tighten nuts to 17 ft-lbs. Turn handlebar full left, then full right to check for clearance.
6. Repeat procedure for installation of left wind deflector (2) on the left side of the vehicle.

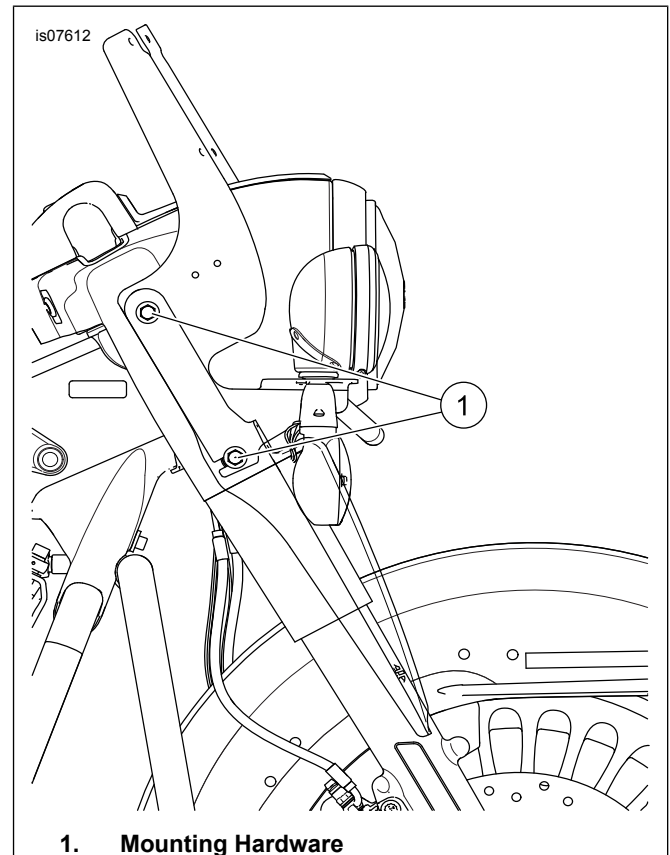

1. Mounting Hardware

Figure 1. Wind Deflector, Right Side View

INSTALLATION FOR 2006-2013 FLHX

1. See Figure 2. On right side of vehicle, locate two mounting screws (2) which secure the fairing and the turn signal bracket to the fork assembly.



Figure 2. Wind Deflector

2. Remove the upper and lower screws and flat washer.
3. Place the wind deflector over the fairing mounting screw holes.
4. Install the turn signal bracket, screw and flat washer removed earlier. Be careful not to pinch turn signal wire between bracket and wind deflector.
5. Adjust wind deflector as far forward as possible to allow for clearance with engine guard. Tighten screws to 17 ft-lbs. Turn handlebar full left, then full right to check clearance.
6. Repeat procedure for installation of left wind deflector (2) on the left side of the vehicle.

INSTALLATION FOR 2014 AND LATER FLHX, FLHXS

1. See Figure 2. On the right side of vehicle, remove the two acorn nuts and turn signal assembly and bracket. Disconnect the wire connector from the signal wire harness. Remove studs (2) that secure fairing to triple clamp. Insert wire connector through hole in wind deflector and place wind deflector (1) against fairing and install studs. Adjust wind deflector as far forward as possible to allow for clearance with engine guard. Tighten studs to 10-15 ft-lbs. Turn handlebar full left, then full right to check for clearance.

2. Reconnect the wire connector for the turn signal. Place turn signal bracket onto the mounting studs and place the two acorn nuts on studs. Tighten the acorn nuts to 10-15 ft-lbs. Take care not to pinch turn signal wire.
3. Repeat procedure for installation of left wind deflector (2) on the left side of the vehicle.

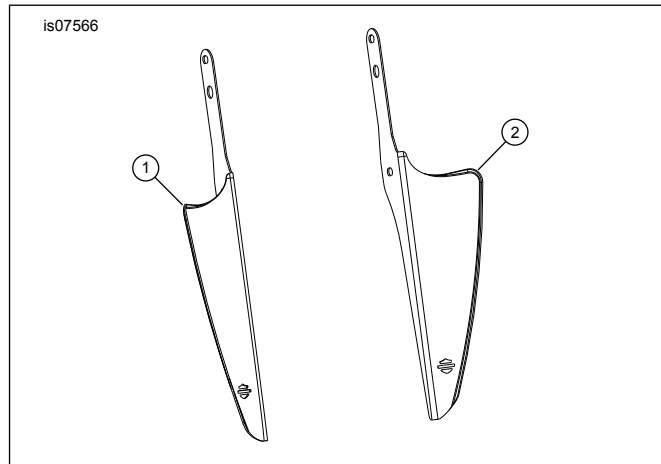

Figure 3. Service Parts: Chrome Wind Deflectors

Table 1. Service Parts

Item	Description (Quantity)	Part Number
1	Wind deflector, right side	Not Sold Separately
2	Wind deflector, left side	Not Sold Separately