



INSTRUCTIONS

J05804

2018-03-23



CHROME BRAKE AND CLUTCH MASTER CYLINDER/RESERVOIR KIT

GENERAL

Kit Numbers

41700263C, 41700263D

Models

For model fitment information, see the P&A Retail Catalog or the Parts and Accessories section of www.harley-davidson.com (English only).

Additional Parts Required

⚠ WARNING

When any hydraulic brake component, line or connection is loosened or replaced on an ABS motorcycle, Digital Technician II must be used during the brake bleeding procedure to verify all air is removed from the system. Failure to properly bleed the brake system could adversely affect braking, which could result in death or serious injury. (00585c)

⚠ WARNING

Rider and passenger safety depend upon the correct installation of this kit. Use the appropriate service manual procedures. If the procedure is not within your capabilities or you do not have the correct tools, have a Harley-Davidson dealer perform the installation. Improper installation of this kit could result in death or serious injury. (00333b)

NOTE

This instruction sheet references service manual information. A service manual for your model motorcycle is required for this installation and is available from a Harley-Davidson dealer.

⚠ WARNING

Brakes are a critical safety component. Contact a Harley-Davidson dealer for brake repair or replacement. Improperly serviced brakes can adversely affect brake performance, which could result in death or serious injury. (00054a)

Tools and Supplies Required

Fresh, uncontaminated DOT 4 brake fluid from a sealed container is required. GM-40M grease (2 gram bag, part number 42820-04) will also be needed. These items are available from a Harley-Davidson Dealer.

If the original brake and clutch levers are re-used, new retaining rings (Part Number 11143) must be installed.

Kit Contents

See Figure 1 and Table 1.

INSTALLATION

Prepare Motorcycle for Service

⚠ WARNING

To prevent accidental vehicle start-up, which could cause death or serious injury, remove main fuse before proceeding. (00251b)

1. Remove main fuse.

Remove and Install Clutch Fluid Reservoir

1. Follow the instructions in the service manual for the following procedures:
 - a. Remove the stock clutch master cylinder/reservoir.
 - b. Install clutch master cylinder/reservoir.
 - c. Fill clutch reservoir.
 - d. Bleed the clutch master cylinder, clutch fluid line and secondary actuator.

Remove and Install Front Brake Fluid Reservoir

1. Follow the instructions in the service manual for the following procedures:
 - a. Remove the stock brake fluid reservoir.
 - b. Install brake fluid reservoir.
 - c. Fill brake fluid reservoir with new DOT 4 brake fluid.
 - d. Bleed the front brake system.

Return the Motorcycle to Service

1. Install the main fuse.
2. With the ignition/light key switch turned to IGNITION, actuate the front brake hand lever to verify operation of the brake lamp.

⚠ WARNING

Be sure that no lubricants or fluids get on tires, wheels or brakes when changing fluid. Traction can be adversely affected, which could result in loss of control of the motorcycle and death or serious injury. (00047d)

▲ WARNING

After repairing the brake system, test brakes at low speed. If brakes are not operating properly, testing at high speeds can cause loss of control, which could result in death or serious injury. (00289a)

3. Test ride the motorcycle.
 - a. If the brake feels spongy, repeat the front brake bleeding procedure.
 - b. If the clutch drags or if the transmission shifts hard, repeat the clutch bleeding procedure.

SERVICE PARTS

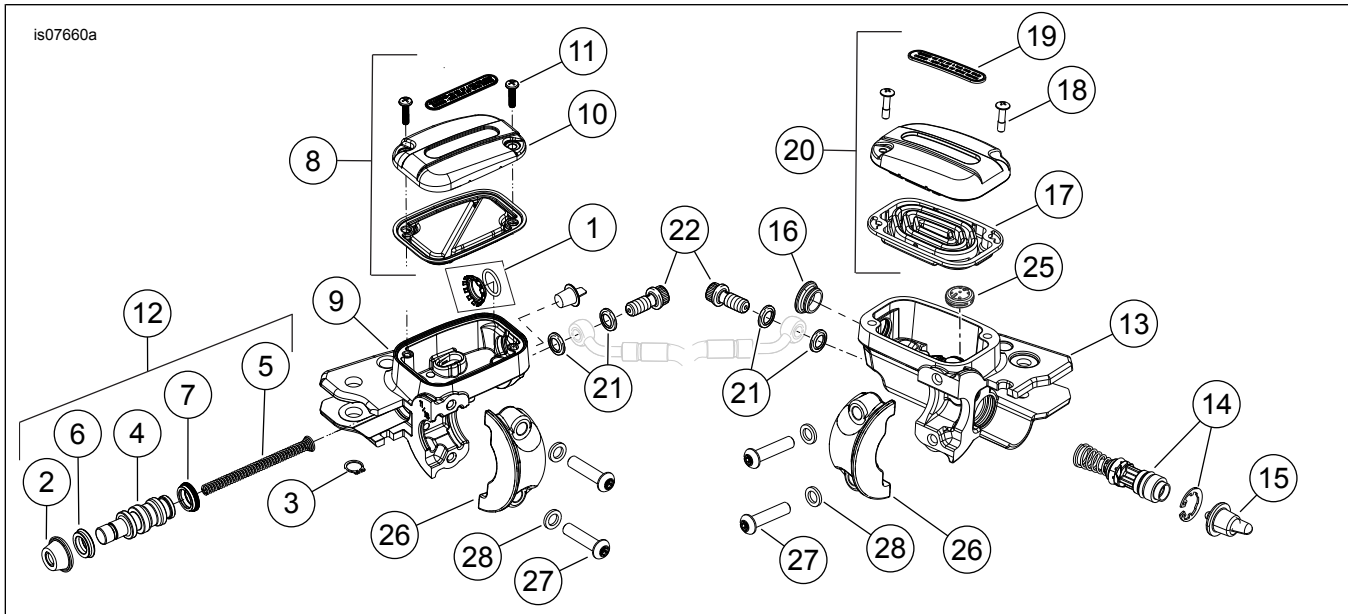

Figure 1. Service Parts: Chrome Clutch and Brake Master Cylinder/Reservoir Kit

Table 1. Service Parts: Chrome Master Cylinder/Reservoir Kit

Item	Description (Quantity)	Part Number
1	Service Kit includes: • O-ring Sight glass	42145-06
2	Dust cap	Not Sold Separately
3	Retaining ring	11143
4	Piston	Not Sold Separately
5	Spring	Not Sold Separately
6	Secondary cup	Not Sold Separately
7	Primary cup	Not Sold Separately
8	Kit, chrome clutch cover	36700094
9	Body, clutch reservoir	Not Sold Separately
10	Cover, master cylinder	Not Sold Separately
11	Screw (2)	3089
12	Rebuild Kit includes items 2, 3, 4, 5, 6, 7	37200096A
13	Body, brake reservoir	Not Sold Separately
14	Repair Kit	42862-06B
15	Pushrod kit	42861-06B
16	Sightglass kit	42854-06
17	Gasket	Not Sold Separately
18	Screw (2)	Not Sold Separately
19	Decal	Not Sold Separately
20	Front Master Cylinder Cover Kit includes items 18 and 19	42123-08
21	Gasket, brakeline (4)	41751-06A
22	Banjo bolt, brakeline (4)	42010-06A
23	Clutch master cylinder assembly, front, chrome, Includes items 1, 3, 8, 9, 12	36700081C
24	Brake master cylinder assembly, front, chrome, Includes items 13-16, 20, 25	42102-08D
25	Anti-bubble button	41700367
26	Clamp, brake and clutch reservoir, chrome	42119-08

Table 1. Service Parts: Chrome Master Cylinder/Reservoir Kit

Item	Description (Quantity)	Part Number
27	Screw (4)	4293
28	Washer (4)	6099