



INSTRUCTIONS

J05725

2014-11-20



AGGRESSOR FRONT WHEELS

GENERAL

⚠ WARNING

Install only wheels and installation kits approved for your model motorcycle. Contact a Harley-Davidson dealer to verify fitment. Mismatching wheels and installation kits or installing wheels not approved for your model can cause loss of control, which could result in death or serious injury. (00610c)

Kit Numbers

43300321, 43300373 and 43300385

Models

For model fitment information, see the P&A Catalog or the Parts and Accessories section of www.harley-davidson.com (English only).

NOTE

Accessory hub caps are not compatible with this wheel style.

Kit Contents

These kits include the custom wheel. See Table 1 for kit contents.

Installation Requirements

Proper installation of this kit requires the separate purchase of the following parts which are available at a Harley-Davidson dealer:

- Wheel Installation Kit (See Table 2 and Table 3 to determine required installation kit.)
- Brake Disc Screws - 10 stock screws (3655A) or 2 chrome screw kits (46646-05) includes 5 screws.
- Two Aggressor style floating brake rotor kits (41500102 (left) and 41500103 (right)).
- Wheel Bearing Remover and Installer (94134-09A)

Optional Installation (Except 43300373): Harley-Davidson® Original Equipment angled valve stem may be installed. See a Harley-Davidson dealer for part numbers and proper torque specifications.

⚠ WARNING

Rider and passenger safety depend upon the correct installation of this kit. Use the appropriate service manual procedures. If the procedure is not within your capabilities or you do not have the correct tools, have a Harley-Davidson dealer perform the installation. Improper installation of this kit could result in death or serious injury. (00333b)

NOTE

This instruction sheet references service manual information. A service manual for your model motorcycle is required for this installation and is available from a Harley-Davidson dealer.

Recommended Products

The following Harley-Davidson Genuine Motor Accessories are recommended for proper maintenance and cleaning:

- Chrome Clean & Shine (93600031 (US) / 93600082 (International))
- Glaze Poly Sealant (93600026 (US) / 93600079 (International))
- Harley® Wheel and Spoke Brush (43078-99)
- Wheel & Tire Cleaner (93600024 (US) / 93600076 (International))

INSTALLATION

1. Remove existing front wheel assembly. Save axle, axle nut and wheel spacers for kit installation. Refer to FRONT WHEEL in service manual.

NOTE

Install short valve stem (43157-83A) included in the installation kit. Discard all other valve stems.

2. See Figure 1. Install valve stem assembly (L) on wheel. Refer to TIRES in service manual.

NOTE

Install the primary bearing first using appropriate service manual and WHEEL BEARING REMOVER/INSTALLER.

The side with the DOT marking is the primary bearing side.

The bearing shims provided in the installation kits are not required and can be discarded.

NOTICE

Do not re-use brake disc/rotor screws. Re-using these screws can result in torque loss and damage to brake components. (00319c)

3. Assemble wheel installation kit components and brake disc(s) to wheel, using the appropriate service parts table. Refer to FRONT WHEEL in service manual.
4. Install previously removed wheel spacers. Refer to FRONT WHEEL in service manual.
5. Install front wheel (1), stock axle and stock axle nut. Refer to FRONT WHEEL in service manual.



MAINTENANCE AND CLEANING

Chrome parts must be maintained regularly to verify that they keep their original shine and luster.

1. Clean heavily-soiled wheel surfaces using Harley-Davidson Wheel and Tire Cleaner, applied with Harley Wheel and Spoke Brush.

2. Thoroughly clean chrome with a good quality chrome cleaner, such as Harley Bright Chrome Cleaner.
3. After cleaning and polishing, seal the finish with a good quality sealer, such as Harley Glaze Polish and Sealant.

SERVICE PARTS

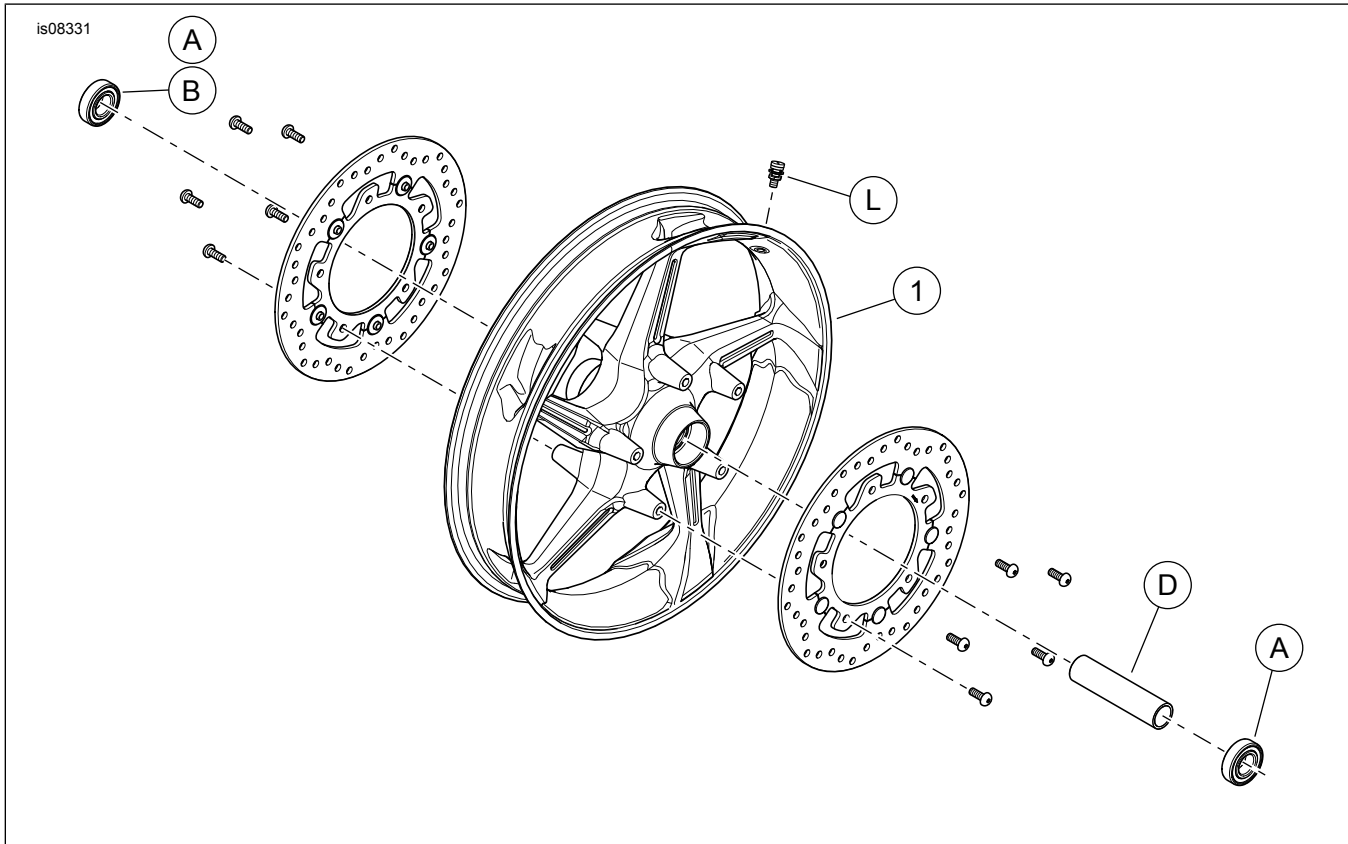

Figure 1. Service Parts: Aggressor Front Wheel Kits

Table 1. Service Parts and Wheel Kit Contents

Kit	Item	Description (Quantity)	Part Number
43300321, 43300373 and 43300385	1	Wheel	Not Sold Separately

Table 2. FRONT 25 mm Bearing Wheel Installation Kit (41455-08C)

FRONT 25 mm Bearing Wheel Installation Kit (41455-08C)		ITEM (Quantity Used and Description)							
Fitment	Wheel Size	A	C	D	J	K	L	M	N
2008 Touring; 2009 and later FLHRC (non-ABS) and Trike (non-ABS)	16 x 3.0 in	2	0	1	0	**	*	*	*
2009 and later Touring (non-ABS)	17 x 3.0 in	2	0	1	0	0	*	*	*
2008 and later Touring (non-ABS)	18 x 3.5 in	2	0	1	0	**	*	*	*
2008 and later Dyna (except FLD, FXDWG and FXDF)	19 x 2.5 in	2	1	0	**	0	*	*	0
2008 and later VRSCAW, VRSCD, VRSCF and VRSCDX (non-ABS)	19 x 3.0 in	2	1	0	**	0	*	*	0
2009 and later Touring (non-ABS)	19 x 3.5 in	2	0	1	0	0	*	*	*

Table 2. FRONT 25 mm Bearing Wheel Installation Kit (41455-08C)

FRONT 25 mm Bearing Wheel Installation Kit (41455-08C)		ITEM (Quantity Used and Description)							
Fitment	Wheel Size	A	C	D	J	K	L	M	N
Installation kits are designed to work with many different wheel styles and fitments. Contact a Harley-Davidson dealer to verify that the wheel and installation kits are both designed and approved for the motorcycle they are being installed on. NOTES: * See <i>NOTE</i> above valve installation step in INSTALLATION to determine which valve stem to use for your particular kit. Discard other valve stem(s). ** See <i>NOTES</i> for your wheel kit above the wheel assembly step in INSTALLATION to determine if bearing shim is used for your particular wheel kit and fitment. *** Bearing shim installed under the primary bearing.		A	Bearing, regular (2)		9276A				
		C	Axle sleeve		41748-08				
		D	Axle sleeve		41900-08				
		J	Bearing shim***		41450-08				
		K	Bearing shim***		43903-08				
		L	Valve stem, short		43157-83A				
		M	Valve stem, long		43206-01				
		N	Valve stem, pull thru		40999-87				

Table 3. FRONT 25 mm Bearing ABS Wheel Installation Kit (41454-08B)

FRONT 25 mm Bearing ABS Wheel Installation Kit (41454-08B)		ITEM (Quantity Used and Description)								
Fitment	Wheel Size	A	B	C	D	J	K	L	M	N
2008 Touring and 2009 and later FLHRC with ABS	16 x 3.0 in	1	1	0	1	0	**	*	*	0
2009 and later Touring with ABS	17 x 3.0 in	1	1	0	1	0	0	*	*	*
2008 and later Touring with ABS	18 x 3.5 in	1	1	0	1	**	**	*	*	*
2012 and later Dyna with ABS (Except FLD, FXDWG and FXDF)	19 x 2.5 in	1	1	1	0	**	0	*	*	0
2008 and later VRSCAW, VRSCD, VRSCF and VRSCDX with ABS	19 x 3.0 in	1	1	1	0	**	**	*	*	0
2009 and later Touring with ABS	19 x 3.5 in	1	1	0	1	0	0	*	*	*
Installation kits are designed to work with many different wheel styles and fitments. Contact a Harley-Davidson dealer to verify that the wheel and installation kits are both designed and approved for the motorcycle they are being installed on. NOTES: * See <i>NOTE</i> above valve installation step in INSTALLATION to determine which valve stem to use for your particular kit. Discard other valve stem(s). ** See <i>NOTES</i> for your wheel kit above the wheel assembly step in INSTALLATION to determine which bearing shim to use for your particular wheel kit and fitment. *** Red side of bearing must be installed toward the wheel. The ABS bearing is primary. **** Bearing shim installed under the primary bearing.		A	Bearing, regular		9276A					
		B	Bearing, ABS***		9252					
		C	Axle sleeve		41748-08					
		D	Axle sleeve		41900-08					
		J	Bearing shim****		41450-08					
		K	Bearing shim****		43903-08					
		L	Valve stem, short		43157-83A					
		M	Valve stem, long		43206-01					
	N	Valve stem, pull thru		40999-87						