



# INSTRUCTIONS

J04051

2016-09-21



## SLOTTED 6-SPOKE FRONT WHEEL KITS

### GENERAL

#### ⚠ WARNING

Install only wheels and installation kits approved for your model motorcycle. Contact a Harley-Davidson dealer to verify fitment. Mismatching wheels and installation kits or installing wheels not approved for your model can cause loss of control, which could result in death or serious injury. (00610c)

### Kit Numbers

43920-08, 43921-08, 43973-08, 43918-07, 43919-07, 44058-07, 44057-07, 44055-07, 44056-07, 43924-07, 43925-07, 43538-09, 43549-09, 43577-09

### Models

For model fitment information, see the P&A Retail Catalog or the Parts and Accessories section of [www.harley-davidson.com](http://www.harley-davidson.com) (English only).

#### NOTE

Accessory hub caps are not compatible with this wheel.

### Kit Contents

These kits include the custom wheel, and depending on the kit, may also include a hub cap. See Figure 2. and Table 3 for kit contents.

### Additional Parts Required

If installing Kits 43577-09, 43549-09 or 43538-09 on a vehicle originally equipped with stock cast wheels, separate purchase of a stock floating brake rotor (42040-06) is required.

Proper installation of this kit requires the separate purchase of the following parts which are available at a Harley-Davidson dealer:

- Tires ( Refer to Table 2. )
- Wheel Installation Kit ( Refer to Table 4. through Table 11 to determine required installation kit.)
- Brake Disc Screws ( See Figure 1. and Table 1 )
- Wheel Bearing Remover and Installer (94134-09A)

The following Harley-Davidson Genuine Motor Accessories are recommended for proper maintenance and cleaning:

- Chrome Clean & Shine (93600031 [US] and 93600082 [non-US])
- Glaze Poly Sealant (93600026 [US] and 93600079 [non-US])
- Harley® Wheel and Spoke Brush (43078-99)
- Wheel & Tire Cleaner (93600024 [US] and 93600076 [non-US])

- Bare Aluminum Wheel Protectant (99846-10)

#### ⚠ WARNING

Rider and passenger safety depend upon the correct installation of this kit. Use the appropriate service manual procedures. If the procedure is not within your capabilities or you do not have the correct tools, have a Harley-Davidson dealer perform the installation. Improper installation of this kit could result in death or serious injury. (00333b)

#### NOTE

This instruction sheet references service manual information. A service manual for this year/ model motorcycle is required for this installation. One is available from a Harley-Davidson dealer.

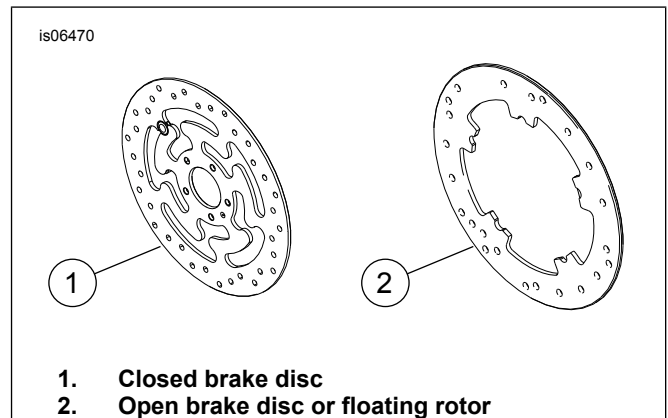

Figure 1. Front Brake Disc Styles

Table 1. Front Disc Hardware Fitment

Brake Disc	Hardware
Closed disc	5 Stock disc screws (3655A)
	Chrome screw kit (46646-05) includes 5 screws
Open disc	5 Stock disc screws (3762M) and 5 disc washers (6966M)

NOTE: Models equipped with dual front brakes and models being equipped with a wheel with dual brake mounting surfaces require twice as many screws/washers (10 total screws or 2 chrome screw kits if available).

### INSTALLATION

1. Remove existing front wheel assembly. Save axle, axle nut, brake disc and wheel spacers for kit installation. Refer to FRONT WHEEL in service manual. **For FLSTC and FLSTN Models:** Discard moon-style hub cap. **For FXSTD Models:** Discard tapered spacer.

#### NOTE

- Install long valve stem (43206-01) included in the installation kit. Discard all other valve stems.



- See Figure 2. Install valve stem assembly (L, M or N) on wheel. Refer to TIRES in service manual.

**NOTE**

Install the primary bearing first using appropriate service manual and WHEEL BEARING REMOVER/INSTALLER.

**For Kits 43918-07 and 43919-07:**

- The side of the wheel with the valve stem and directional arrow is the right side of the wheel.
- The left side of the wheel is the primary bearing side.

**For Kits 43920-08 and 43921-08:**

- The left side of the wheel has a machined groove in the hub face to identify it as the primary bearing side.
- Install the wheel so that the valve stem is on the right side of the motorcycle.

**For Kits 44055-07, 44056-07, 44057-07, 44058-07, 43538-09, 43549-09 and 43577-09:**

- The wheel should be installed so that the hub markings are on the left side of the motorcycle. An arrow cast into the rim of Kits 44055-07, and 44056-07 indicates the direction of rotation. A groove is machined in the left-side hub face to indicate the primary bearing side.
- For dual brake disc models, install the brake disc according to the service manual. The chrome hub cap (2) is not used.
- For single brake disc models, install the brake disc according to the service manual. The chrome hub cap (2) is installed on the opposite side of the wheel from the brake disc.
- For kits 43538-09, 43549-09 and 43577-09 install the bearing shim (J) included in the installation kit under the primary bearing.
- For Kits 44055-07 and 44056-07: The gross axle weight ratings is unaffected by the installation of this wheel on a vehicle equipped with a 19-inch wheel.
- For Kits 44057-07 and 44058-07: The gross axle weight ratings is unaffected by the installation of this wheel on a vehicle equipped with a 21-inch wheel.

**For Kit 43924-07, 43925-07 and 43973-08:**

- For 2006 and later FXDWG Models: When correctly installed, the tire will be 2–5 mm (0.08–0.2 in) off of center, compared to the fender.

- The right side of the wheel has a machined groove in the hub face. An arrow is cast into the rim on the right side to indicate the direction of rotation.
- For 2007 and later FX Softail Models and 2008 and later FXDWG Models: The left side of the wheel is the primary bearing side. For all other models the right side of the wheel is the primary bearing side.
- For FXSTS Models:** The brake disc is installed on the right side of the wheel.
- For all other models:** The brake disc is installed on the left side of the wheel.

**NOTICE**

**Do not re-use brake disc/rotor screws. Re-using these screws can result in torque loss and damage to brake components. (00319c)**

- Assemble the wheel installation kit components and brake disc(s) to wheel, using the appropriate service parts table. Refer to FRONT WHEEL in Service Manual.
- For FLSTC and FLSTN Models:** Install wheel kit and right side wheel spacer provided in installation kit. Refer to FRONT WHEEL in Service Manual. **For FXSTS Models:** Install the spacer provided in the installation kit between the stock left side spacer and the left fork. **For FXSTD Models:** Install wheel kit, stock wheel spacer and right side wheel spacer to replace the tapered spacer discarded in Step 1. Refer to FRONT WHEEL in service manual. **For all other models:** Install previously removed wheel spacers. Refer to FRONT WHEEL in service manual.
- Install front wheel (1), stock axle and stock axle nut. Refer to FRONT WHEEL in service manual.

**MAINTENANCE AND CLEANING**

Chrome parts must be maintained regularly so that they keep their original shine and luster.

- Clean heavily-soiled wheel surfaces using Wheel & Tire Cleaner, applied with Harley Wheel and Spoke Brush.
- Thoroughly clean chrome with a good quality chrome cleaner, such as Harley Chrome Clean & Shine.
- After cleaning and polishing, seal the finish with a good quality sealer, such as Glaze Poly Sealant.

**Table 2. Recommended Tire Combinations**

Kit Installation	Recommended Tire	Front Tire Part No.	Rear Tire Part No.
44057-07 - Installed on a 2014-Later 1200V	Dunlop GT502BW	40554-04A	40555-04A
	Dunlop D401 BW	43112-91A	43264-02
	Dunlop D401 WWW	55193-10	55192-10
	Michelin Scorcher "31" BW	43258-07B	40878-11
44055-07 and 44056-07 - Installed on a 2014-Later 883N	Dunlop D401 MWWW	43100004	43200007
	Michelin Scorcher "31" BW	41036-12	40878-11

# SERVICE PARTS

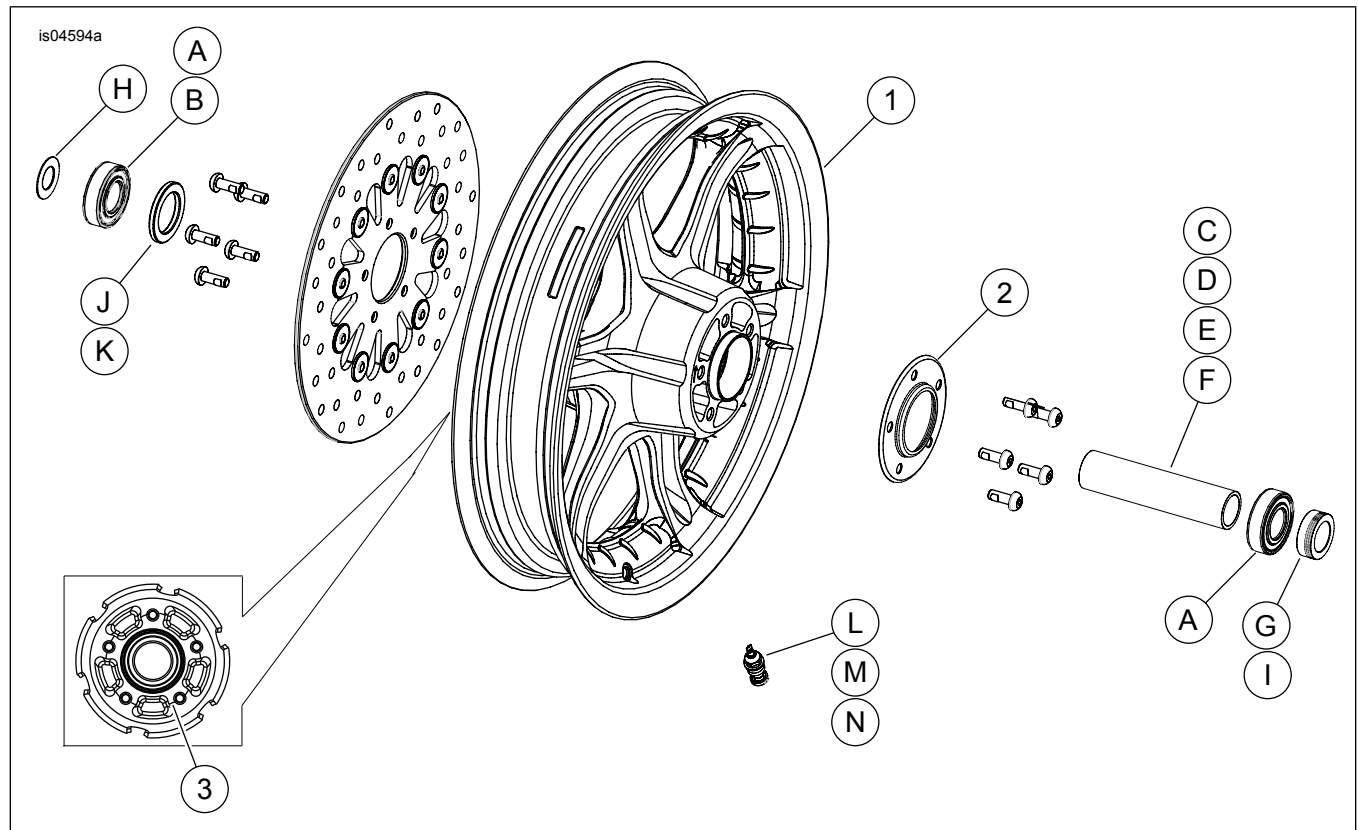

Figure 2. Service Parts: Front Slotted Six-Spoke Wheel (16-inch wheel shown)

Table 3. Service Parts and Wheel Kit Contents

Kit	Item	Description (Quantity)	Part Number
43920-08, 43921-08	1	Wheel	Not Sold Separately
43918-07, 43919-07, 44058-07, 44057-07, 44055-07, 44056-07, 43924-07, 43925-07, 43973-08, 43538-09, 43549-09, 43577-09	1 2	Wheel Hub cap	Not Sold Separately 43986-00
Visual indicator mentioned in text:			
	3	Machined groove (all wheels)	

Table 4. FRONT 3/4 Inch Bearing Wheel Installation Kit (43833-07A)

FRONT 3/4 Inch Bearing Wheel Installation Kit (43833-07A)		ITEM (Quantity Used and Description)									
Fitment	Wheel Size	A	C	D	E	G	H	I	L	M	
2000-2006 FLST and FLSTF (except 2006 FLSTFSE2)	16 x 3.0 in	2	0	1	0	0	0	0	*	*	
2000-2006 FLSTC and FLSTN	16 x 3.0 in	2	0	1	0	0	0	1	*	*	
2006 FLSTFSEi	17 x 3.5 in	2	0	1	0	0	0	1	*	*	
2008-later FLSTSB	18 x 3.5 in	2	0	***	0	***	0	0	*	*	
2000-2007 XL; 2000-2003 Dyna (except FXDWG)	19 x 2.5 in	2	0	0	1	0	0	0	*	*	
2000-2007 XL; 2000-2003 Dyna (except FXDWG)	21 x 2.15 in	2	0	0	1	0	0	0	*	*	
2000-2006 FXST/B/C; 2000-2005 FXDWG**	21 x 2.15 in	2	1	0	0	0	0	0	*	*	
2000-2006 FXSTS**	21 x 2.15 in	2	1	0	0	0	1	0	*	*	
2000-2006 FXSTD (Except FXSTDSE)**	21 x 2.15 in	2	1	0	0	1	0	0	*	*	

**Table 4. FRONT 3/4 Inch Bearing Wheel Installation Kit (43833-07A)**

FRONT 3/4 Inch Bearing Wheel Installation Kit (43833-07A)		ITEM (Quantity Used and Description)									
Fitment	Wheel Size	A	C	D	E	G	H	I	L	M	
Installation kits are designed to work with many different wheel styles and fitments. Contact a Harley-Davidson dealer to verify that the wheel and installation kits are both designed and approved for the motorcycle they are being installed on. NOTES: * See NOTE above valve installation step in INSTALLATION to determine which valve stem to use for your particular kit. Discard other valve stem(s). ** The right side of the wheel is the primary bearing side for this fitment. *** See INSTALLATION section for separate hardware kit to be used for FLSTSB models.		A	Bearing, regular (2)					9267			
		C	Axle sleeve					43536-00			
		D	Axle sleeve					43608-00			
		E	Axle sleeve					43613-00			
		G	Spacer, axle					40910-00A			
		H	Spacer, axle					43313-98			
		I	Spacer, wheel					43617-00A			
		L	Valve stem, short					43157-83A			
	M	Valve stem, long					43206-01				

**Table 5. FRONT 1 Inch Bearing Wheel Installation Kit (43848-08A)**

FRONT 1 Inch Bearing Wheel Installation Kit (43848-08A)		ITEM (Quantity Used and Description)							
Fitment	Wheel Size	A	C	D	E	F	L	M	
2000-2007 Touring	16 x 3.0 in	2	1	0	0	0	*	*	
2004-2007 Touring	18 x 3.5 in	2	1	0	0	0	*	*	
2004-2005 Dyna (except FXDWG)	19 x 2.5 in	2	0	0	0	1	*	*	
2006-2007 Dyna (except FXDWG)	19 x 2.5 in	2	0	0	1	0	*	*	
2002-2007 VRSC	19 x 3.0 in	2	0	0	1	0	*	*	
2006-2007 FXDWG**	21 x 2.15 in	2	0	1	0	0	*	*	
2004-2005 Dyna (except FXDWG)	21 x 2.15 in	2	0	0	0	1	*	*	
Installation kits are designed to work with many different wheel styles and fitments. Contact a Harley-Davidson dealer to verify that the wheel and installation kits are both designed and approved for the motorcycle they are being installed on. NOTES: * See NOTE above valve installation step in INSTALLATION to determine which valve stem to use for your particular kit. Discard other valve stem(s). ** The right side of the wheel is the primary bearing side for this fitment.		A	Bearing, regular (2)					9247	
		C	Axle sleeve					43517-00	
		D	Axle sleeve					43633-06	
		E	Axle sleeve					43641-01	
		F	Axle sleeve					43755-04	
		L	Valve stem, short					43157-83A	
		M	Valve stem, long					43206-01	

**Table 6. FRONT 25 mm Bearing Non-ABS Wheel Installation Kit (41455-08C)**

FRONT 25 mm Bearing Non-ABS Wheel Installation Kit (41455-08C)		ITEM (Quantity Used and Description)								
Fitment	Wheel Size	A	C	D	J	K	L	M	N	
2008 Touring; 2009 and later FLHRC (non-ABS) and Trike (non-ABS)	16 x 3.0 in	2	0	1	0	1	*	*	*	
2009 and later Touring (non-ABS)	17 x 3.0 in	2	0	1	0	0	*	*	*	
2008 and later Touring (non-ABS)	18 x 3.5 in	2	0	1	0	**	*	*	*	
2008 - 2017 Dyna (except FLD, FXDWG, FXDF)	19 x 2.5 in	2	1	0	**	0	*	*	0	
2008 - 2017 VRSCAW, VRSCD, VRSCF, VRSCDX (non-ABS)	19 x 3.0 in	2	1	0	**	0	*	*	0	
2009 and later Touring (non-ABS)	19 x 3.5 in	2	0	1	0	0	*	*	*	
2017 and later FLTRX, FLTRXS, FLTRXSE (non-ABS)	21 x 3.5 in	2	0	1	0	0	*	*	*	
Installation kits are designed to work with many different wheel styles and fitments. Contact a Harley-Davidson dealer to verify that the wheel and installation kits are both designed and approved for the motorcycle they are being installed on. NOTES: * See NOTE above valve installation step in INSTALLATION to determine which valve stem to use for your particular kit. Discard other valve stem(s). ** See NOTES for your wheel kit above the wheel assembly step in INSTALLATION to determine if bearing shim is used for your particular wheel kit and fitment. *** Bearing shim installed under the primary bearing.		A	Bearing, regular (2)					9276B		
		C	Axle sleeve					41748-08		
		D	Axle sleeve					41900-08		
		J	Bearing shim***					41450-08		
		K	Bearing shim***					43903-08		
		L	Valve stem, short					43157-83A		
		M	Valve stem, long					43206-01		
	N	Valve stem, pull thru					40999-87			

**Table 7. FRONT 25 mm Bearing Wheel Installation Kit (43851-11A)**

FRONT 25 mm Bearing Wheel Installation Kit (43851-11A)		ITEM (Quantity Used and Description)								
Fitment	Wheel Size	A	C	G	H	J	L	M	N	
2007 and later FLSTC, FLSTN and FLS (non-ABS)	16 x 3.0 in	2	1	0	1	1	*	*	*	
2008 and later FXDF	16 x 3.0 in	2	1	0	0	0	*	*	*	
2007 and later FLSTF and FLSTFB (non-ABS)	17 x 3.5 in	2	1	0	0	0	*	*	*	
2008 and later FLSTF and FLSTFB (non-ABS)	18 x 3.5 in	2	1	0	0	0	*	*	*	
2008 and later FXDF; 2012 and later FLD	18 x 3.5 in	2	1	0	0	0	*	*	*	
2007 and later FXS, FXST/B/C (non-ABS); 2008 and later FXDWG***	21 x 2.15 in	2	1	0	0	1	*	*	*	
2007 FXSTD***	21 x 2.15 in	2	1	1	0	1	*	*	*	

**Table 7. FRONT 25 mm Bearing Wheel Installation Kit (43851-11A)**

FRONT 25 mm Bearing Wheel Installation Kit (43851-11A)		ITEM (Quantity Used and Description)							
Fitment	Wheel Size	A	C	G	H	J	L	M	N
Installation kits are designed to work with many different wheel styles and fitments. Contact a Harley-Davidson dealer to verify that the wheel and installation kits are both designed and approved for the motorcycle they are being installed on. NOTES: * See NOTE above valve installation step in INSTALLATION to determine which valve stem to use for your particular kit. Discard other valve stem(s). ** Bearing shim installed under the primary bearing. *** The left side of the wheel is the primary bearing side for this fitment.		A	Bearing, regular (2)		9276				
		C	Axle sleeve		41349-07				
		G	Spacer, axle		41504-07				
		H	Spacer, axle		41695-07				
		J	Bearing shim**		43315-07				
		L	Valve stem, short		43157-83A				
		M	Valve stem, long		43206-01				
		N	Valve stem, pull-thru		40999-87				

**Table 8. FRONT 25 mm Bearing ABS Wheel Installation Kit (41454-08B)**

FRONT 25 mm Bearing ABS Wheel Installation Kit (41454-08B)		ITEM (Quantity Used and Description)								
Fitment	Wheel Size	A	B	C	D	J	K	L	M	N
2008 Touring and 2009 and later FLHRC with ABS	16 x 3.0 in	1	1	0	1	0	1	*	*	0
2009 and later Touring with ABS	17 x 3.0 in	1	1	0	1	0	0	*	*	*
2008 and later Touring with ABS	18 x 3.5 in	1	1	0	1	**	**	*	*	*
2012 - 2017 Dyna with ABS (Except FLD, FXDWG and FXDF)	19 x 2.5 in	1	1	1	0	**	**	*	*	0
2008 - 2017 VRSCAW, VRSCD, VRSCF and VRSCDX with ABS	19 x 3.0 in	1	1	1	0	**	**	*	*	0
2009 and later Touring with ABS	19 x 3.5 in	1	1	0	1	0	0	*	*	*
2017 and later FLTRX, FLTRXS, FLTRXSE with ABS	21 x 3.5 in	1	1	0	1	0	0	*	*	*
Installation kits are designed to work with many different wheel styles and fitments. Contact a Harley-Davidson dealer to verify that the wheel and installation kits are both designed and approved for the motorcycle they are being installed on. NOTES: * See NOTE above valve installation step in INSTALLATION to determine which valve stem to use for your particular kit. Discard other valve stem(s). ** See NOTES for your wheel kit above the wheel assembly step in INSTALLATION to determine which bearing shim to use for your particular wheel kit and fitment. *** Red side of bearing must be installed toward the wheel. The ABS bearing is primary. **** Bearing shim installed under the primary bearing.		A	Bearing, regular		9276B					
		B	Bearing, ABS***		9252A					
		C	Axle sleeve		41748-08					
		D	Axle sleeve		41900-08					
		J	Bearing shim****		41450-08					
		K	Bearing shim****		43903-08					
		L	Valve stem, short		43157-83A					
		M	Valve stem, long		43206-01					
	N	Valve stem, pull thru		40999-87						

**Table 9. FRONT 25 mm Bearing Wheel Installation Kit (42400008)**

FRONT 25 mm Bearing Wheel Installation Kit (42400008)		ITEM (Quantity Used and Description)							
Fitment	Wheel Size	A	C	D	E	K	L	M	N
2015 and later XG500/XG750	17 x 2.5 in	2	1	0	0	0	1	0	0
2010 and later XL1200X; 2011 and later XL1200C	16 x 3.0 in	2	0	0	1	0	*	*	*
2008 and later XL (except XL1200X and 2011 and later XL883L)	19 x 2.5 in	2	1	0	0	1	*	*	*
2008 and later XL (except XL1200X and 2011 and later XL883L)	21 x 2.15 in	2	1	0	0	1	*	*	*
2013 and later FXSB (non-ABS)	21 x 3.5 in	2	0	1	0	0	*	*	*
Installation kits are designed to work with many different wheel styles and fitments. Contact a Harley-Davidson dealer to verify that the wheel and installation kits are both designed and approved for the motorcycle they are being installed on. NOTES: * See NOTE above valve installation step in INSTALLATION to determine which valve stem to use for your particular kit. Discard other valve stem(s). ** Bearing shim installed under the primary bearing.		A	Bearing, regular (2)		9276A				
		C	Axle sleeve		43906-08				
		D	Axle sleeve		43300200				
		E	Axle sleeve		11888				
		K	Bearing shim**		43315-07				
		L	Valve stem, short		43157-83A				
		M	Valve stem, long		43206-01				
		N	Valve stem, pull thru		40999-87				

**Table 10. FRONT 25 mm Bearing ABS Wheel Installation Kit (42400009A)**

FRONT 25 mm Bearing ABS Wheel Installation Kit (42400009A)		ITEM (Quantity Used and Description)								
Fitment	Wheel Size	A	B	C	D	E	K	L	M	N
2013 and later FXSB with ABS	21 x 3.5 in	1	1	0	1	0	0	1	0	0
2014 and later XL1200X and XL1200C with ABS	16 x 3.0 in	1	1	0	0	1	0	*	*	*
2014 and later XL (except XL1200C, XL1200X and XL883L) with ABS	19 x 2.5 in	1	1	1	0	0	1	*	*	0
2014 and later XL (except XL1200C, XL1200X and XL883L) with ABS	21 x 2.15 in	1	1	1	0	0	1	*	*	0
2017 and later XG500 and XG750 with ABS	17 x 2.5 in	1	1	1	0	0	0	*	*	*

**Table 10. FRONT 25 mm Bearing ABS Wheel Installation Kit (42400009A)**

FRONT 25 mm Bearing ABS Wheel Installation Kit (42400009A)		ITEM (Quantity Used and Description)									
Fitment	Wheel Size	A	B	C	D	E	K	L	M	N	
Installation kits are designed to work with many different wheel styles and fitments. Contact a Harley-Davidson dealer to verify that the wheel and installation kits are both designed and approved for the motorcycle they are being installed on. NOTES: * See NOTE above valve installation step in INSTALLATION to determine which valve stem to use for your particular kit. Discard other valve stem(s). ** Red side of bearing must be installed toward the wheel. The ABS bearing is the primary bearing. *** Bearing shim installed under the primary bearing.		A	Bearing, regular					9276A			
		B	Bearing, ABS**					9252			
		C	Axle sleeve					43906-08			
		D	Axle sleeve					43300200			
		E	Axle sleeve					11888			
		K	Bearing shim***					43315-07			
		L	Valve stem, short					43157-83A			
		M	Valve stem, long					43206-01			
	N	Valve stem, pull-thru					40999-87				

**Table 11. FRONT 25 mm Bearing ABS Wheel Installation Kit (42400010)**

FRONT 25 mm Bearing ABS Wheel Installation Kit (42400010)		ITEM (Quantity Used and Description)									
Fitment	Wheel Size	A	B	C	G	J	K	L	M	N	
2011 and later FLSTC, FLSTN and FLS with ABS	16 x 3.0 in	1	1	1	1	0	1	*	*	*	
2012 and later FXDF with ABS	16 x 3.0 in	1	1	1	0	0	0	*	*	*	
2011 and later FLSTF and FLSTFB with ABS	17 x 3.5 in	1	1	1	0	0	0	*	*	*	
2011 and later FLSTF and FLSTFB with ABS	18 x 3.5 in	1	1	1	0	0	0	*	*	*	
2012 and later FXDF and FLD with ABS	18 x 3.5 in	1	1	1	0	0	0	*	*	*	
2011 and later FXS, FXST and 2012 and later FXDWG with ABS	21 x 2.15 in	1	1	1	0	0	1	*	*	*	
Installation kits are designed to work with many different wheel styles and fitments. Contact a Harley-Davidson dealer to verify that the wheel and installation kits are both designed and approved for the motorcycle they are being installed on. NOTES: * See NOTE above valve installation step in INSTALLATION to determine which valve stem to use for your particular kit. Discard other valve stem(s). ** Red side of bearing must be installed toward the wheel. The ABS bearing is the primary bearing. *** Bearing shim installed under the primary bearing.		A	Bearing, regular					9276A			
		B	Bearing, ABS**					9252			
		C	Axle sleeve					41349-07			
		G	Spacer					41695-07			
		J	Bearing shim***					41448-08			
		K	Bearing shim***					43315-07			
		L	Valve stem, short					43157-83A			
		M	Valve stem, long					43206-01			
	N	Valve stem, pull-thru					40999-87				