



# INSTRUCTIONS

J05273

2016-09-21



## FRONT FAT-X WHEEL

### GENERAL

#### ⚠ WARNING

Install only wheels and installation kits approved for your model motorcycle. Contact a Harley-Davidson dealer to verify fitment. Mismatching wheels and installation kits or installing wheels not approved for your model can cause loss of control, which could result in death or serious injury. (00610c)

### Kit Numbers

43300045

### Models

For model fitment information, see the P&A Retail Catalog or the Parts and Accessories section of [www.harley-davidson.com](http://www.harley-davidson.com) (English only).

#### NOTE

Accessory hub caps are not compatible with this wheel.

### Kit Contents

This kit includes the custom wheel only. See Figure 2 and Table 2

### Additional Parts Required

Proper installation of this kit requires the separate purchase of the following parts which are available at a Harley-Davidson dealer:

- Wheel Installation Kit ( Refer to Table 2. )
- Brake Disc Screws ( See Figure 1. and Refer to Table 1. )
- Wheel Bearing Remover and Installer (94134-09)

The following Harley-Davidson Genuine Motor Accessories are recommended for proper maintenance and cleaning:

- Chrome Clean & Shine (93600031 [US] and 93600082 [non-US])
- Glaze Poly Sealant (93600026 [US] and 93600079 [non-US])
- Harley® Wheel and Spoke Brush (43078-99)
- Wheel & Tire Cleaner (93600024 [US] and 93600076 [non-US])
- Bare Aluminum Wheel Protectant (99846-10)

#### ⚠ WARNING

Rider and passenger safety depend upon the correct installation of this kit. Use the appropriate service manual procedures. If the procedure is not within your capabilities or you do not have the correct tools, have a Harley-Davidson dealer perform the installation. Improper installation of this kit could result in death or serious injury. (00333b)

#### NOTE

This instruction sheet references service manual information. A service manual for this year/model motorcycle is required for this installation. One is available from a Harley-Davidson dealer.

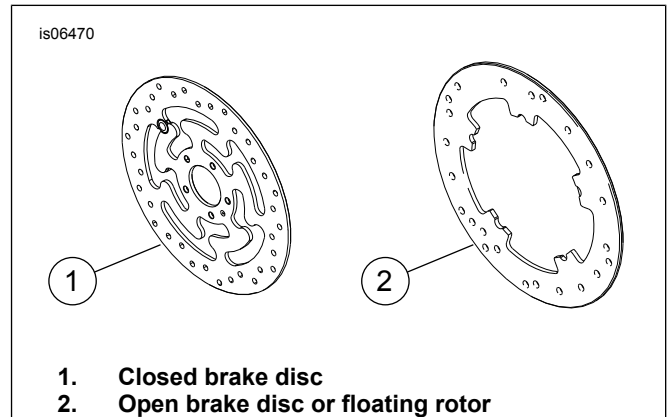

Figure 1. Front Brake Disc Styles

Table 1. Front Disc Hardware Fitment

Brake Disc	Hardware
Closed disc	5 Stock disc screws (3655A)
	Chrome screw kit (46646-05) includes 5 screws
Open disc	5 Stock disc screws (3762M) and 5 disc washers (6966M)
NOTE: Models equipped with dual front brakes and models being equipped with a wheel with dual brake mounting surfaces require twice as many screws/washers (10 total screws or 2 chrome screw kits if available).	

### INSTALLATION

1. Remove existing front wheel assembly. Save axle, axle nut, brake disc and wheel spacers for kit installation. Refer to FRONT WHEEL in service manual.

#### NOTE

Install pull thru valve stem (40999-87) included in the installation kit. Discard all other valve stems.

**NOTICE**

**Do not re-use brake disc/rotor screws. Re-using these screws can result in torque loss and damage to brake components. (00319c)**

- See Figure 2. Install valve stem assembly (N) on wheel. Refer to TIRES in service manual.

**NOTE**

Install the primary bearing first using appropriate service manual and WHEEL BEARING REMOVER/INSTALLER.

The brake mounting surfaces on the left side of the wheel indicate the primary bearing side.

- Assemble the wheel installation kit components and brake disc(s) to wheel, using the appropriate service parts table. Refer to FRONT WHEEL in service manual.

- Install previously removed wheel spacers. Refer to FRONT WHEEL in service manual.
- Install front wheel (1), stock axle and stock axle nut. Refer to FRONT WHEEL in service manual.

**MAINTENANCE AND CLEANING**

Chrome parts must be maintained regularly so that they keep their original shine and luster.

- Clean heavily-soiled wheel surfaces using Wheel & Tire Cleaner, applied with Harley Wheel and Spoke Brush.
- Thoroughly clean chrome with a good quality chrome cleaner, such as Harley Chrome Clean & Shine.
- After cleaning and polishing, seal the finish with a good quality sealer, such as Glaze Poly Sealant.

**SERVICE PARTS**

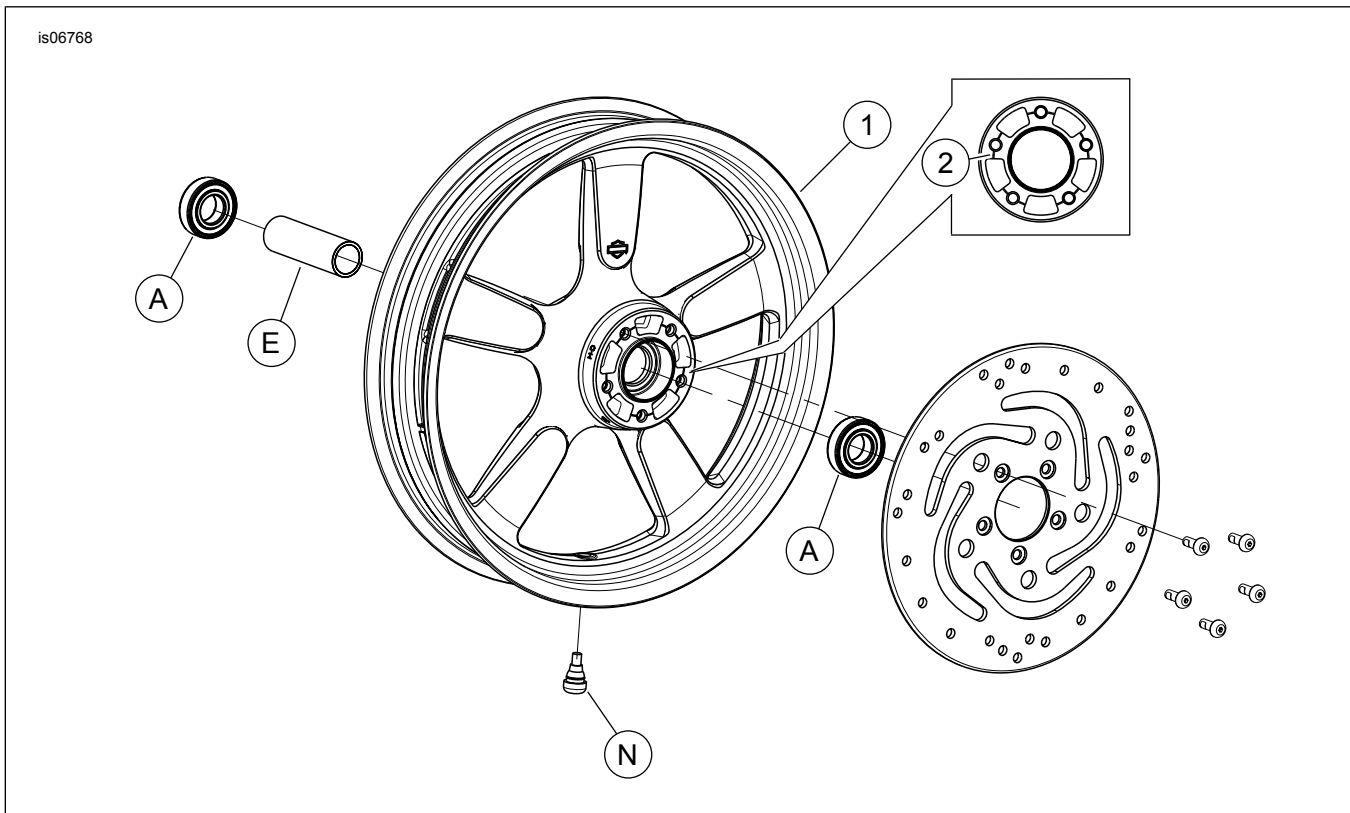

Figure 2. Service Parts: Front Fat-X Wheel

Table 2. Service Parts and Wheel Kit Contents

Kit	Item	Description (Quantity)	Part Number
43300045	1	Wheel	Not Sold Separately
		Visual indicator mentioned in text:	
	2	Machined groove (all wheels)	

Table 3. FRONT 25 mm Bearing Wheel Installation Kit (42400008)

FRONT 25 mm Bearing Wheel Installation Kit (42400008)		ITEM (Quantity Used and Description)							
Fitment	Wheel Size	A	C	D	E	K	L	M	N
2015 and later XG500/XG750	17 x 2.5 in	2	1	0	0	0	1	0	0
2010 and later XL1200X; 2011 and later XL1200C	16 x 3.0 in	2	0	0	1	0	*	*	*
2008 and later XL (except XL1200X and 2011 and later XL883L)	19 x 2.5 in	2	1	0	0	1	*	*	*
2008 and later XL (except XL1200X and 2011 and later XL883L)	21 x 2.15 in	2	1	0	0	1	*	*	*

**Table 3. FRONT 25 mm Bearing Wheel Installation Kit (42400008)**

FRONT 25 mm Bearing Wheel Installation Kit (42400008)		ITEM (Quantity Used and Description)								
Fitment	Wheel Size	A	C	D	E	K	L	M	N	
2013 and later FXSB (non-ABS)	21 x 3.5 in	2	0	1	0	0	*	*	*	
Installation kits are designed to work with many different wheel styles and fitments. Contact a Harley-Davidson dealer to verify that the wheel and installation kits are both designed and approved for the motorcycle they are being installed on. NOTES: * See NOTE above valve installation step in INSTALLATION to determine which valve stem to use for your particular kit. Discard other valve stem(s). ** Bearing shim installed under the primary bearing.		A	Bearing, regular (2)		9276A					
		C	Axle sleeve		43906-08					
		D	Axle sleeve		43300200					
		E	Axle sleeve		11888					
		K	Bearing shim**		43315-07					
		L	Valve stem, short		43157-83A					
		M	Valve stem, long		43206-01					
		N	Valve stem, pull thru		40999-87					

**Table 4. FRONT 25 mm Bearing ABS Wheel Installation Kit (42400009A)**

FRONT 25 mm Bearing ABS Wheel Installation Kit (42400009A)		ITEM (Quantity Used and Description)								
Fitment	Wheel Size	A	B	C	D	E	K	L	M	N
2013 and later FXSB with ABS	21 x 3.5 in	1	1	0	1	0	0	1	0	0
2014 and later XL1200X and XL1200C with ABS	16 x 3.0 in	1	1	0	0	1	0	*	*	*
2014 and later XL (except XL1200C, XL1200X and XL883L) with ABS	19 x 2.5 in	1	1	1	0	0	1	*	*	0
2014 and later XL (except XL1200C, XL1200X and XL883L) with ABS	21 x 2.15 in	1	1	1	0	0	1	*	*	0
2017 and later XG500 and XG750 with ABS	17 x 2.5 in	1	1	1	0	0	0	*	*	*
Installation kits are designed to work with many different wheel styles and fitments. Contact a Harley-Davidson dealer to verify that the wheel and installation kits are both designed and approved for the motorcycle they are being installed on. NOTES: * See NOTE above valve installation step in INSTALLATION to determine which valve stem to use for your particular kit. Discard other valve stem(s). ** Red side of bearing must be installed toward the wheel. The ABS bearing is the primary bearing. *** Bearing shim installed under the primary bearing.		A	Bearing, regular		9276A					
		B	Bearing, ABS**		9252					
		C	Axle sleeve		43906-08					
		D	Axle sleeve		43300200					
		E	Axle sleeve		11888					
		K	Bearing shim***		43315-07					
		L	Valve stem, short		43157-83A					
		M	Valve stem, long		43206-01					
N	Valve stem, pull-thru		40999-87							