



INSTRUCTIONS

J06407

2017-08-22



OIL COOLER COVER KIT

GENERAL

Kit Number

62500026, 62500027

Models

For model fitment information, see the P&A Retail Catalog or the Parts and Accessories section of www.harley-davidson.com (English only).

REMOVAL/INSTALLATION

1. Remove oil cooler cover screw and pull out the bottom of the cover and lift it off of the oil cooler.
2. See Figure 1. Slide the top of the new cover (3) so that the tabs catch behind the top of the oil cooler.
3. Push down the cover and align the holes.
4. Install spacer (1) and screw (4). Tighten.
Torque: 13.6–17.6 N·m (10–13 ft-lbs)
5. Clean the surface of the spacer with a mixture of 50 to 70% isopropyl alcohol and 30 to 50% distilled water. Allow surface to dry thoroughly.

NOTE

Ambient temperature should be 21–38 °C (70–100 °F)

6. Remove the protective film and install adhesive medallion (2) onto the spacer (1). Hold for approximately 30 seconds.

NOTE

Allow at least 24 hours before exposing the medallion to vigorous washing, strong water spray or extreme weather

conditions. The adhesive bond will increase to maximum strength after about 72 hours at normal room temperature.

NOTE

To remove cover, medallion will need to be pried off to access screw.

SERVICE PARTS

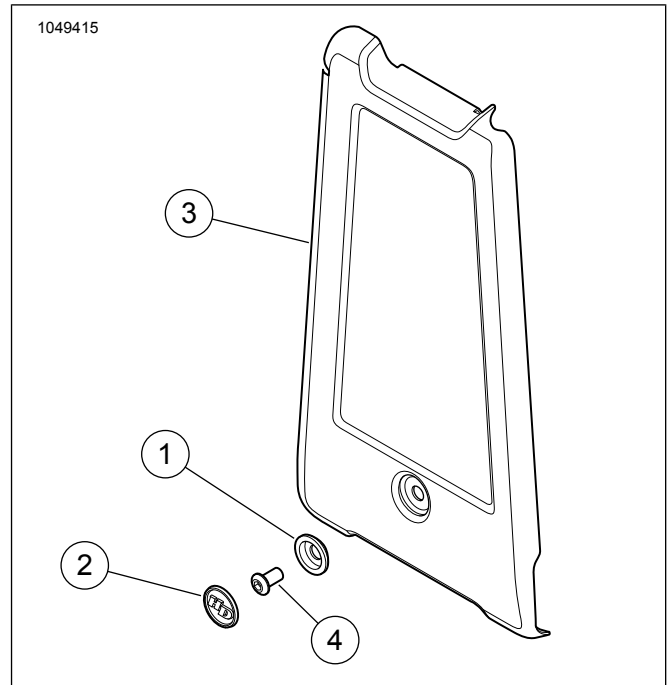

Figure 1. Service Parts: Oil Cooler Cover Kit

Table 1. Service Parts Table

| Item | Description (Quantity) | Part Number |
|------|-------------------------------|---------------------|
| 1 | Spacer, Chrome | Not Sold Separately |
| | Spacer, Gloss black | Not Sold Separately |
| 2 | Medallion | 14100874 |
| 3 | Oil cooler cover, chrome | Not Sold Separately |
| | Oil cooler cover, gloss black | Not Sold Separately |
| 4 | Screw | 4365 |

