



INSTRUCTIONS

J04572

2017-08-22



FOOTPEG KIT

GENERAL

Kit Number

50911-08 (Black), 50978-99 (Chrome), 50976-99 (Chrome, large), 50113-10 (Black, large), 50056-10 (Silencer), 49312-10 (Edge Cut), 33600059 (Burst), 50500787 (Brass, MID), 50500988 (Brass, FWD)

Models

For model fitment information, see the P&A Retail Catalog or the Parts and Accessories section of www.harley-davidson.com (English only).

Installation Requirements

Separate purchase and installation of additional parts or accessories may be required for proper installation of this kit on your model motorcycle. See the P&A Retail Catalog or the Parts and Accessories section of www.harley-davidson.com (English only) for a list of required parts or accessories for your model.

⚠ WARNING

Rider and passenger safety depend upon the correct installation of this kit. Use the appropriate service manual procedures. If the procedure is not within your capabilities or you do not have the correct tools, have a Harley-Davidson dealer perform the installation. Improper installation of this kit could result in death or serious injury. (00333b)

NOTE

This instruction sheet references service manual information. A service manual for your model motorcycle is required for this installation and is available from a Harley-Davidson Dealer.

Kit Contents

See Figure 2 and Table 1.

NOTE

Footpegs in Kits 50911-08 and 50113-10 are designed to show signs of wear. Over time the paint will wear off giving a distressed look.

INSTALLATION

1. Remove the locknuts and screws that hold the existing footpegs in place. If your model motorcycle is equipped with a pin and retaining ring, remove them and retain for future use. Save all hardware for installation of the new footpegs.
2. Remove the existing footpegs along with the spring washers. Save the spring washers for later installation.

NOTE

See Figure 1. When performing the next step, verify that the spring washer is positioned inside of the footpeg support with the square edge (2) towards the inside of the support.

3. See Figure 1. Install the new footpegs in the same manner as the old footpegs were installed. Place a spring washer (1), along with the mount end of the footpeg, inside the slots (3) of the footpeg supports.
4. Secure each footpeg and spring washer with the screw and locknut or pin and retaining ring removed earlier. Tighten locknuts.

Torque: 26 N·m (19 ft·lbs)

⚠ WARNING

Footrests must fold up and toward rear of motorcycle if struck. Failure to set footrests to fold up and back could result in death or serious injury. (00366a)

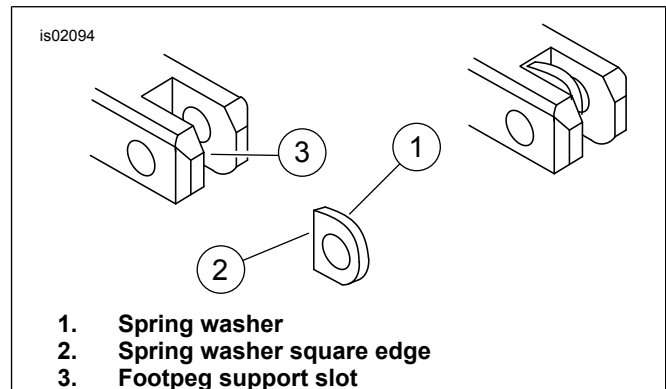

Figure 1. Footpeg Spring Washer Installation

CARE AND CLEANING GUIDELINES FOR BRASS PARTS

Cleaning Instructions

1. Verify part is dry and free of dirt or debris.
2. Place a small amount of Harley-Davidson® Chrome Clean & Shine on a microfiber cloth or detailing swab.
3. Using light pressure, rub the brass parts with the microfiber cloth. For hard to reach places or grooves, use the detailing swab.

Obtaining a Bright Finish

Brass parts will naturally age and darken with time. If a bright brass finish is preferred, place some Harley-Davidson Bare Metal Polish on a microfiber cloth and lightly rub on the brass parts until they reach the desired brightness.



Slowing the Natural Aging Process

To slow the aging process of the brass parts, place a small amount of Harley-Davidson Glaze Poly Sealant on a microfiber cloth or detailing swab, and lightly rub on the parts until the sealant has soaked in.

Precautions

- Use of non-recommended cleaning, polishing and protective products will result in the removal of the aged finish from the brass parts.
- Prolonged contact with certain items (hands, gloves, boots, dust, etc.) and exposure to the elements will also alter all surface finishes and is NOT considered a defect.
- Avoid cleaning parts with abrasive and aggressive chemicals and abrasive cleaning pads.
- Avoid ammoniated products and bleach.
- Prolonged exposure to water will alter the brass finish. Wipe down parts after contact with water.
- Excess rubbing may lighten the surface appearance of the part.

SERVICE PARTS

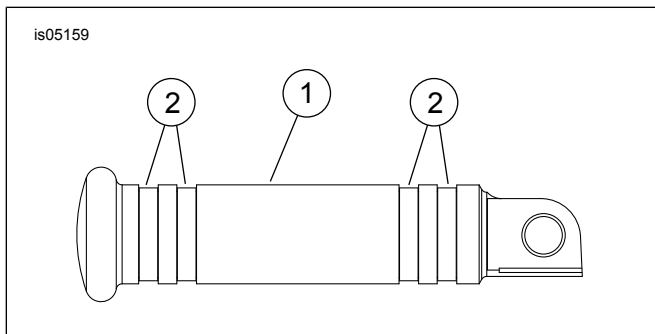

Figure 2. Service Parts: Footpeg Kit (For All Kits Except 50056-10 and 33600059)

Table 1. Service Parts Table

Item	Description (Quantity)	Part Number
1	Billet footpeg assembly	Not Sold Separately
2	Footpeg rubber tread (4) (not shown)(For Kits 50911-08, 50978-99)	11306
	Footpeg rubber tread (4) (not shown)(For Kits 50976-99, 50113-10)	11305
	Footpeg rubber tread (6) (not shown)(For Kit 49312-10)	11306